

**LOGIC ANALYZERS
PM 3580 / PM 3585
User manual**

PHILIPS

Dual logic analysis

PF8690/00 System Software
Software Version 1.0, English
I&E, Test & Measurement
© Copyright 1990, Philips Export B.V.

Publication Number 4022 104 90171

Guarantee Statement

This Philips guarantee is in addition to all rights which the buyer may have against his supplier under the sales agreement between the buyer and the supplier and according to local legislation.

Philips guarantees this product to be free from defects in material and workmanship under normal use and service for a period of one (1) year from the date of shipment. This guarantee does not cover possible required re-calibration and/or standard maintenance actions. This guarantee extends only to the original purchaser and does not apply to fuses, batteries, or to any product or part thereof that has been misused, altered or has been subjected to abnormal conditions of operation and handling.

Fluke/Philips-supplied software is guaranteed to be properly recorded on non-defective media. We will replace improperly recorded media without charge for 90 days after shipment upon receipt of the software. Our software is not guaranteed to be error free.

Philips' obligation under this guarantee is limited to have repaired or replace a product that is returned to an authorized Philips Service Centre within the guarantee period, provided that Philips determines that the product is defective and that the failure has not been caused by misuse, alteration or abnormal operation.

Guarantee service for products installed by Philips will be performed at the Buyer's facility at no charge within Philips' service travel area; outside this area guarantee service will be performed at the Buyer's facility only upon Philips' prior agreement and the Buyer shall pay Philips round trip travel expenses.

If a failure occurs, send the product, freight prepaid to the Service Centre designated by Philips with a description of the difficulty. At Philips' option, repairs will be made or the product will be replaced. Philips shall return the product, F.O.B. Repair Centre, transportation prepaid, unless the product is to be returned to another country, in which case the Buyer shall pay all shipping charges, duties and taxes. Philips assumes NO risk for damage in transit.

Disclaimer

The foregoing guarantee is exclusive and is in lieu of all other guarantees, expressed or implied, including but not limited to any implied guarantee of merchantability, fitness, or adequacy for any particular purpose or use. We shall not be liable for any direct, indirect, special incidental, or consequential damages, whether based on contract, tort, or otherwise.

Some countries or states do not allow the foregoing limitations. Other rights may also vary.

PM 3580/PM 3585 User Manual

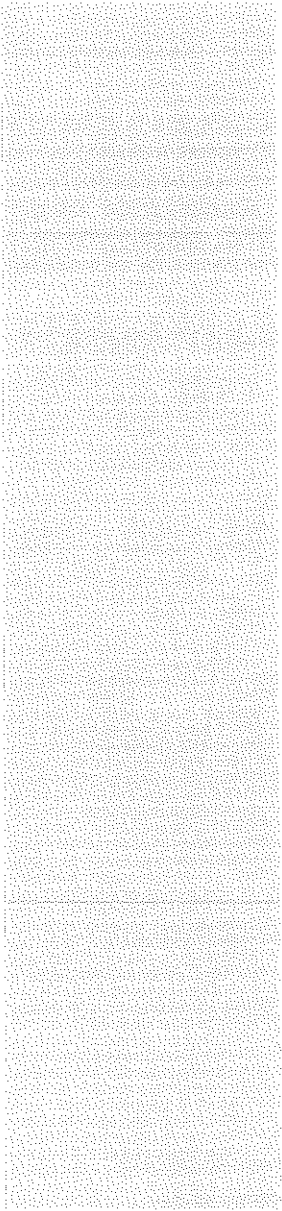

Preface

Thank you for purchasing this PHILIPS logic analyzer. It has been designed and manufactured to the highest quality standards to give you many years of trouble-free and accurate measurements.

Should you have any comments on how this product could be improved then please contact your local Fluke/Philips representative. Fluke/Philips addresses are listed in chapter 11 of this User Manual.

PM 3580/PM 3585 User Manual

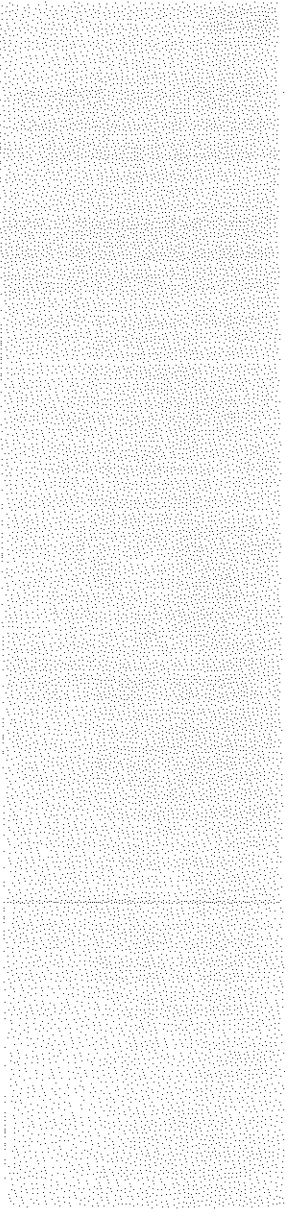

Table of Contents

Guarantee Statement	ii
Disclaimer	iii
Introduction	
The PM 3580 / PM 3585 Family	1-2
Dual Analysis Per Pin Architecture	1-3
Key Features	1-4
Menus	1-5
Basic Measurement Loop	1-5
Default Set up	1-6
Repetitive Runs	1-6
Disk Facilities	1-6
Menu Overview	1-7
Manuals	1-7
Accessories	1-10
Switching on the Logic Analyzer	1-10
Overview of the Instrument	
Front Panel	2-2
Keyboard	2-3
Rear Panel	2-7
Menu Overview	
The Menus	3-2
The Menu Bar	3-2
Menu Fields	3-3
The Analyzer Name Field	3-3
Field Types	3-4
The Configuration Menu	3-6
The Format Menu	3-8
Clock and Label Attributes	3-9
The Threshold Level	3-11
Polarity	3-12
The Trace Menu	3-14
Run Definition Area	3-15
Sequencer Area	3-16
Trigger Words Area	3-17
The Display Menus	3-18
The Special Functions Popup Menu	3-20
Time Origin – T_0	3-21
The I/O Menu	3-22
The Print Menu	3-24
State Clocks	
Sampling of State Data	4-2
Example	4-2
Specifying State Clocks	4-2

- Clock Qualification 4-3
 - Example 4-5
 - Specifying Clock Qualifiers 4-5
- Multiple Clocks 4-6
 - Example 4-6
 - Maximum Number of Clocks and Qualifiers 4-8
- Label Attributes 4-9
 - Valid for Clock 4-9
 - Timing Label 4-11
 - Default Values 4-11
- Clock Attributes 4-12
 - Display on Same Line as 4-12
 - Qualifier(s) 4-13
 - Timing Label 4-14
 - Default Values 4-14
- Multiplexed Busses 4-14
 - Example 4-15

Trace Control

- Trace Control Features 5-3
 - Kind of Data Stored 5-4
 - Triggering 5-5
 - Trigger Point Position 5-5
- Pattern Recognition 5-7
- Timing Pattern Recognizers 5-7
 - Timing Words 5-7
 - Timing Pattern Duration 5-7
 - Glitch Detector 5-8
 - Edge Detector 5-9
- State Pattern Recognizers 5-10
 - State Words 5-10
 - Not State Words 5-11
 - Immediate State Words 5-11
 - Range Detector 5-12
 - Not in Range Detector 5-15
 - State Clocks 5-15
- Combinations of Pattern Recognizers 5-16
- Specifying Patterns for Recognition 5-17
 - Recognizer Fields 5-17
 - Value Entry 5-20
 - Overlapping Labels 5-21
 - Ranges 5-21
- Sequencer Facilities 5-22
 - Level Structure 5-23
 - Creating a Level 5-24
 - Time-Out Value 5-25

- Restart Sequence 5-26
- Examples 5-26
 - Program Flow 5-26
 - Interrupt Response Time 5-28
 - Check Minimum Pulse Width 5-29
 - Check Maximum Pulse Width 5-29
 - Check Pulse Duration 5-30
 - Check Pattern Sequence 5-31
 - Wait for a Pattern Sequence 5-31
 - One Immediate Sequence of Two Patterns 5-32
 - Two Immediate Sequences of Two Patterns 5-33
 - Separately Trigger State and Timing 5-34
- Predefined Sequences 5-35
 - The Predefined Timing Sequences 5-36
 - The Predefined State Sequences 5-37
 - Last User-defined Sequence 5-38
- Repetitive Measurements 5-39
 - Starting Repetitive Measurements 5-39
 - Terminating Repetitive Measurements 5-39
 - Repeat Mode Timer 5-41
- Analyzing the Data**
- Display Concepts 6-2
 - Data Source 6-4
 - Data Type and Form 6-6
 - Reference Data 6-7
 - Data Comparison 6-7
 - Measurement Data Overview 6-8
 - Time Origin - T_0 6-9
 - Time or Sample Numbers 6-10
 - Sample Number 0 6-10
 - Dial Operation 6-11
 - Viewing Parts of the Measurement Data 6-12
 - Display Locators 6-14
 - Measurements (R and S cursors) 6-15
 - Selecting Labels for Display 6-16
 - Display of Sequencer Levels 6-17
- Waveform Displays 6-18
 - Dial Movement (Dial Mode) 6-19
 - X-scale (T/div and S/div) 6-21
 - Y-scale 6-23
 - Bus Data 6-23
 - Waveform Data Representation 6-26
 - Label Values 6-26
 - Accumulate Mode 6-27
- List Displays 6-28
 - Dial Movement (Dial Mode) 6-29
 - List Data Representation 6-30

The Find Function	6-30
"Time" Label	6-31
"Level" Label	6-32
Label Base	6-32
Disassembly	6-33
Split Screen	6-34
Creating a Split Screen	6-34
Deleting a Window	6-35
Active Window	6-35
Moving Between Windows	6-35
Coscroll	6-36
Disassemblers	
Disassembly	7-2
Disassembler Packages	7-2
Microprocessor Adapters	7-2
Loading a Disassembler	7-3
Disassembler Setup	7-3
Instruction Representation	7-5
Instruction Mnemonics	7-5
Operand Field	7-5
Disassembler Parameters	7-6
Display Options	7-7
Translation Options	7-9
Activating/Deactivating the Disassembler	7-10
Probing	
The Pod System	8-2
Front Ends	8-2
Probe Impedance	8-3
Pod Cable	8-3
Standard Front End	8-4
Microprocessor Adapters	8-6
RC Connectors	8-7
Adapter Types	8-7
Disassembler and Setting Files	8-8
RC Connectors	8-9
User Hardware Specifications	
Floppy Disk Drive	9-2
Centronics Connector	9-3
IEEE-488 Connector	9-4
RS232 Connector	9-5
Video Connector	9-6
Pod Cable Connector	9-7
File Formats	
Hardcopy File	10-2
Header	10-2
Screen Image	10-2

Safety and Installation

- Initial Inspection 11-2
- Operator Safety 11-3
 - Safety Precautions 11-3
 - Caution and Warning Statements 11-3
 - Symbols 11-4
 - Impaired Safety Protection 11-4
 - Safety Notice 11-4
- Installation 11-6
 - Working Position 11-6
 - Earthing 11-6
 - Setting the Line Voltage 11-7
 - Switching on the Logic Analyzer 11-9
 - Setting the Date and Time 11-10
- Fluke/Philips Addresses 11-11
 - U.S.A. 11-24

Utilities

- Utility Disk 12-2
- Setting the Date and Time 12-3
- Formatting Disks 12-4
- Copying Disks 12-4

Index

Microprocessor Support

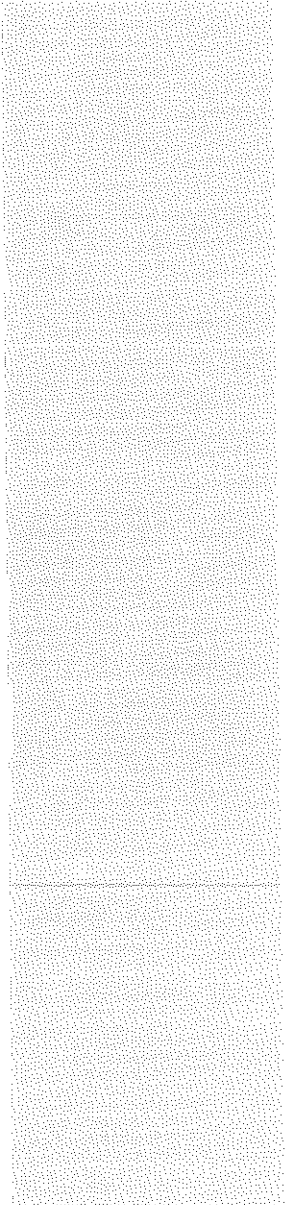

**RELEASE
NOTE
PF 8690/00**

Indicator : Customer information.
Indicator number : CIS 1116
Concerns : PF 8690/00 System Software,
Version 1.03, English
for PM 3580/PM 3585 Logic An-
alyzers
Issue date : October 1991
To be inserted in : PM 3580/PM 3585 User Manual

General

Please read the following notes carefully before you start working. They contain some important information on the differences between this and previous versions, as well as describing a number of minor limitations and restrictions.

Version 1.03 software contains a number of significant enhancements, as well as a number of cosmetic changes and bug-fixes. Most of the enhancements relate to the display capabilities and Chapter 6 of the User Manual ("Analyzing the Data") has been extended. A brief list of the new display features, as well as the other changes, follows. For full details, refer to the User Manual.

**New DISPLAY
Menu Features**

- Waveform display mode for state data.
- List display for timing data.
- Graph display for bus data ("chart mode").
- Accumulate mode for waveform data.
- Cursor control/readout (X, Y, R, S, R-S) can be in samples or time.
- Coscroll of upper/lower screens can be in samples or time.
- Waveform displays can be reset to a default "Best" horizontal scale (T/Div or S/Div).

User Configuration File

Another major enhancement is the user configuration file - "USER.CFG". A brief list of applications follows. For full details, refer to the manual contained on the utilities disk in the file "USER_CFG.MAN".

- Previous software versions only supported printing to Epson compatible printers. You can now configure printer drivers for a wide range of printers. The USER.CFG file includes parameter sets for several popular printers. The necessary instructions for each printer are "commented out" (with "*" symbols). To select a specific printer you should edit (on a PC) out the "*" symbols in the relevant section of USER.CFG. Similarly you can use one of these as a template for some other custom driver for a printer model not on the list.
- Enable/disable screen-saver: Blanks the screen after a user-definable "idle time". The floppy-disc light flashes to indicate that the unit is still switched on. To select the screen-saver all you have to do is edit the appropriate line in USER.CFG. Remove the comment and set the timeout value to the required number of minutes.
- Set date and time format.

Other New Features or Improvements

-
- Ascii print of state/time list between R and S cursors.
 - Auto-repeat compare (eg. "babysit mode") can be performed between intervals defined by samples or times. This avoids the confusing results which could previously be obtained when comparing state data acquired at different clock speeds.
 - The current channel number is displayed during channel editing in the FORMAT menu.
 - Various improvements in the consistency checking and warnings relating to user-defined settings.

Cosmetic changes and Bug-Fixes

- Improved display priority for overlapping cursor flags (in particular the currently active cursor has priority; in previous versions this sometimes "disappeared" as the cursor was scrolled past another non-active cursor).
- Disassembler files are protected from being inadvertently deleted/overwritten.
- After executing a "System reset" in the CONFIG menu, disas will be (re-)loaded from disk when required and not from memory as is currently the case in previous software versions.

System version 1.03 contains many small changes, including fixes for some bugs and inconsistencies which have been discovered and a number of small improvements relating to the operation ("cosmetic" changes). The most significant of these are:

- The pre-defined trigger sequence:
 $t_7 < \text{Pulse duration} < (t_7 + t_8)$
does not work correctly in previous versions. This has now been changed to:
 $t_7 < \text{Pulse duration} < t_8$
This sequence now works correctly. You fill in the same pattern values for tw_7 and tw_8 and the required lower/upper time limits for t_7 and t_8 .
- In previous versions, under certain conditions the trigger point was flagged in the displayed data in the wrong place. This has been corrected.
- Range value in TRACE can now be entered in decimal mode.
- The DELETE action in the FIND window in a state and timing list has been inhibited. This lead a number of users to inadvertently delete labels.
- In Auto-Repeat mode ("stop on state not-equal") previous software versions compared all channels (whether defined for state acquisition or not). This could in certain

cases lead to an incorrect stop. In version 1.03, only channels attached to a state clock are compared.

- In previous versions, an attempt to copy a file to a disk which does not have enough space for the file would corrupt the disk. This has been fixed.
- A number of "catastrophic" bugs have been located and fixed.

Application Notes

A number of important points to note in setting up or operating the analyzer:

Selective Data Acquisition

This function is described on page 50 of the Reference Guide. However the description does not state clearly enough that the global selective data storage qualifier only operates on data acquired prior to the trigger point.

After the trigger point all valid states are stored irrespective of the global storage condition. So for example, if you want to set up the analyzer to qualify all stored data according to the global storage condition, you should set the trigger position (page 40 of the Reference Guide) to "End".

Note that you must ensure that the final trigger condition is only met after the required amount of data has been stored. In this way the data memory can be filled with qualified states (prior to the trigger point).

State Time Tags

Time tag values in a state list can sometimes differ by 5 ns from the times of the appropriate edges as measured in the timing display. This is simply a reflection of the internal 5 ns sampling resolution of the timing acquisition circuitry.

Time Difference Measurements

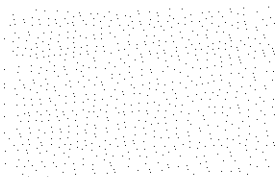

The R-S field in the display only gives 3/4 figure accuracy, so resolution is lost when the units are 10us or longer. If greater accuracy is required in a time difference measurement the individual R and S cursor values must be read out individually and manually subtracted (see page 76 of the Reference Guide).

Time Point Reconstructions

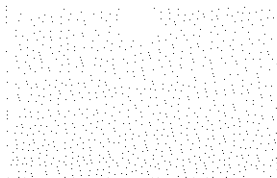

After stopping data acquisition and before displaying the data, a software algorithm is used to locate the precise trigger point in the data. Every effort has been made to minimize the time taken, though in certain cases (usually complex trigger sequences) it can still be rather long (several seconds).

Manual Synchronization of Disassemblers

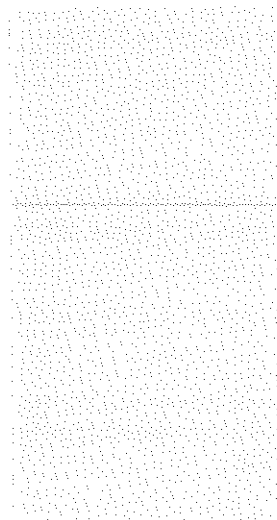

Synchronization information entered in the display via the Disa Parameters pop-up is not saved in the measurement file.

Known Restrictions

As far as we are aware, version 1.03 system software is free of bugs. However a number of restrictions have been brought to our attention.

Disassembly Parameters

With split-screen display where both windows contain the same disassembled data, it is not possible to enter different disassembly parameters for the two windows (eg. one with data transfers shown, the other not shown).

Using Timing Filters ($tw_7 > t_7$ or $tw_8 > t_8$)

If tw_7 is already true at the moment a level is entered, then the condition $tw_7 > t_7$ is also immediately true (similarly for tw_8).

When using filter times, please keep in mind that the tw_7 and tw_8 trigger recognizers only operate at 20 ns intervals (not 5 ns). For further details see page 5-7 of the User Manual.

Booting with Volume Label "SYSTEM"

If you attempt to boot with a floppy formatted with the MS-DOS volume label "SYSTEM", then the analyzer will not boot.

Relative /Absolute Time Tag

On page 94 of the Reference Guide it states that the "Relative" time column gives the time from the previous line. In fact it gives the time to the next line.

Immediate Triggering with Qualified Clocks

Immediate state word triggering does not always work correctly when clocks are qualified. This typically applies in the case of processors such as the 80286, and is illustrated by the diagram below. A qualified clock, c1, is defined when the signal "qual" is high. Defining an immediate trigger condition "If sw₁₂" with "sw₁=value1" and "sw₂=value3" will not cause the analyzer to trigger. This is because the immediate word recognizer incorrectly "sees" the unqualified "value 2". To trigger correctly, you should use the 2 level sequence as follows:

```
L1  If  sw1  goto L2
L2  If  sw2  Stop
      Or if  $\overline{\text{sw2}}$  goto L1
```

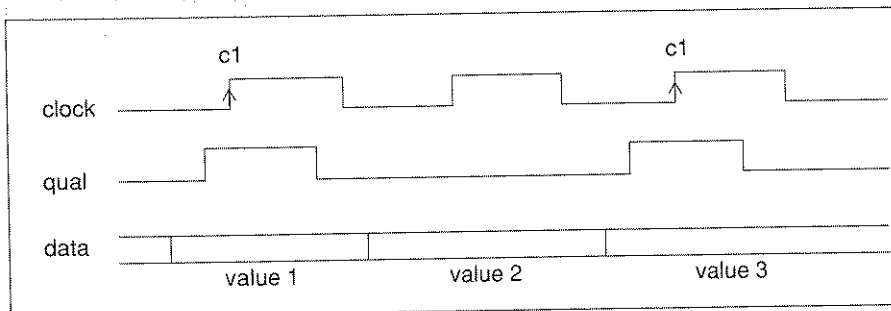

Measurement File Format

Version 1.03 has extensions to the format of the measurement files. Files created by version 1.03 can not be read on systems booted with earlier software versions. However, files created by these versions can still be read on systems booted with version 1.03.

Contents of the System Software Disk

The following files are to be found on the 1.03 version System Software disk:

- SYSTEM System boot file for logic analyzer operation.
 - USER.CFG User configuration file (see above).
 - DEMODISA.DIS Demonstration disassembler (based on 68000).
 - DEMODISA.NEW Sample data for demonstration disassembler.
 - TIMING.NEW Sample timing data file.
 - TIMETRIG.NEW Sample timing data file
 - STATE.NEW Sample state data file.
 - LTAR_TMI.SET
 - LTAR_GMI.SET
 - LTAR_SMI.SET
 - LTAR_MII.SET
- } Settings/Data files to be used in conjunction with PF 8669/20 training target.

Contents of the Utility Disk

The following files are to be found on the 1.03 version Utility disk:

- SYSTEM System boot file for operation of utilities package.
- USER_CFG.MAN On-disk manual (DOS-text) for user configuration file.
- MEAS_2MAN On-disk manual (DOS-text) describing measurement file format for System Software versions 1.02.
- MEAS_3.MAN On-disk manual (DOS-text) describing measurement file format for System Software versions 1.03
- PRMEAS.EXE PC-DOS utility for printing out in ASCII the contents of a measurement file.

- PRMEAS.MAN On-disk manual (DOS-text) for PRMEAS.
- RASCONV.EXE PC-DOS utility for converting a screen-print file into a GIF or SUN raster image format for subsequent processing (eg. import into document).
- RASCONV.MAN On-disk manual (DOS-text) for RASCONV.

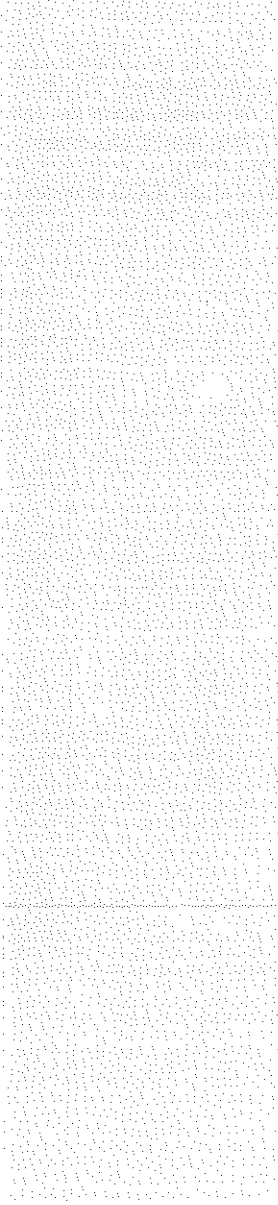

Chapter 1

Introduction

The PM 3580 / PM 3585 Family 1-2
Dual Analysis Per Pin Architecture 1-3
Key Features 1-4
Menus 1-5
 Basic Measurement Loop 1-5
 Default Set up 1-6
 Repetitive Runs 1-6
 Disk Facilities 1-6
 Menu Overview 1-7
Manuals 1-7
Accessories 1-10
Switching on the Logic Analyzer 1-10

The PM 3580 / PM 3585 Family

Dual Analysis Per Pin

The PM 3580/PM 3585 Logic analyzer family is a new generation of general purpose logic analyzers giving twice the information with only half the work.

All four models of this family (PM 3580/30, PM 3580/60, PM 3585/60, PM 3585/90) feature an exclusive Dual Analysis Per Pin architecture allowing these instruments to analyze and store state *and* timing data on each of up to 96 channels in a single acquisition at full speed, all time correlated. No more dual probing; no more repeat measurements needed.

Performance

The PM 3580 instruments handle 100 MHz timing and 50 MHz state acquisition on all channels simultaneously.

The PM 3585 instruments handle 200 MHz timing and 50 MHz state acquisition on all channels simultaneously.

User Interface

Operation of the instruments is more intuitive and easier than ever to learn. The modern human interface is user-friendly both in understanding and operation. Whenever you need them, popup menus will remind you of the choices available. So even if you do not use a logic analyzer very often, you will not be guessing. And when you know exactly where you want to be, you will find the short cuts even faster. For instance, you can type 'T' to move the display directly to the trigger point. No menu needs to be involved.

Dual Analysis Per Pin Architecture

The new Dual Analysis Per Pin (DAPP) architecture makes simultaneous state **and** timing analysis possible per pin with **single probing**. The basic DAPP architecture is shown below.

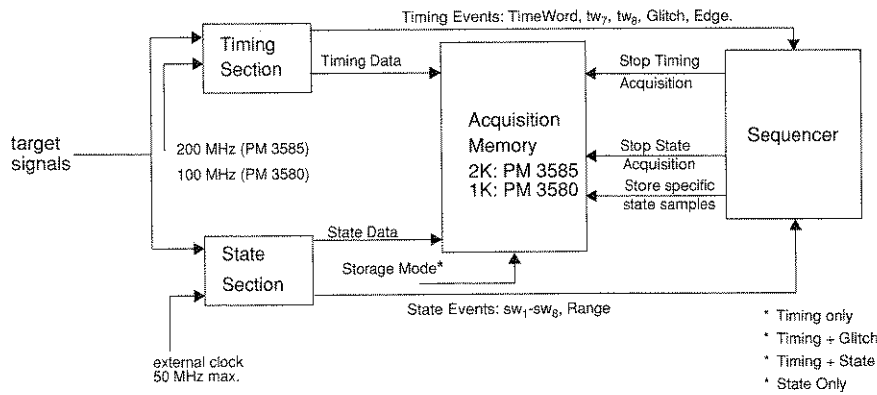

Simultaneous State and Timing Per Pin

Both a timing section and a state section simultaneously observe the same target signals. The pattern recognition results (timing events and state events) of both sections are routed to one common sequencer. The sampled timing and state data are routed to the acquisition memory which can store a total of 2K samples (1K for PM 3580 units) and which you can assign to timing only data (100%), timing + glitch data (50%/50%), timing + state data (50%/50%), or state only data (100%).

The pattern recognition logic for state and timing patterns operates independently from the storage mode you select. This allows you always to search for state and timing patterns in parallel.

PM3585: Two Analyzers

Inside your PM 3585 Logic Analyzer there are two independent Logic Analyzers, both having this unique Dual Analysis Per Pin architecture. These two analyzers can

External Clocks

arm each other when and where necessary in their respective sequences.

Channels can be assigned in groups of 16 to either analyzer or remain unassigned.

Both PM 3580 and PM 3585 units can use any channel as a state/external clock. Furthermore, any channel can be used as a clock qualifier. This is another unique feature of this logic analyzer family.

A maximum of 4 state clocks can be defined at the same time (per analyzer in PM 3585 units).

Transitional Timing

Timing data is stored using the transitional timing mechanism. This guarantees an optimal usage of acquisition memory.

Key Features

The key features of all four models are as follows:

- "Dual Analysis Per Pin (DAPP)" architecture (simultaneous, correlated state and timing acquisition on all channels)
- Transitional timing on all channels
- Powerful triggering functionality integrating state & timing trigger functions in the same trigger sequence
- Eight-level sequencer with full conditional structure (If...Then...Else)
- Eight state trigger words
- One range recognizer
- Three timing trigger words
- One edge detector
- One glitch detector
- Absolute or relative time stamp, always at full speed (5 ns resolution)
- Powerful selective data acquisition functions.

Menus

Basic Measurement Loop

In using a logic analyzer you generally go through the following basic measurement loop:

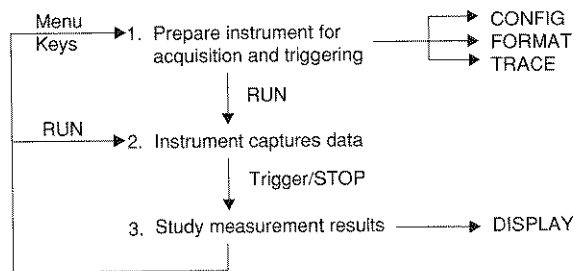

In the first step you prepare the instrument for data acquisition. You should specify:

1. Which pods are relevant,
2. The threshold levels of the signals,
3. The signal names and attributes,
4. The sequence of patterns to search for,
5. Which data is to be stored (Timing only, Timing + Glitch, Timing + State, or State only).

You do this by using the 3 menus referred to as:

- Configuration (CONFIG)
- Format (FORMAT)
- Trace (TRACE)

After you have set up the instrument, press the *RUN* key.

The analyzer now captures data and searches for the sequence of patterns specified. As soon as the analyzer has found the trigger sequence, it stops data acquisition and shows you the results in the DISPLAY menu.

You can then study the results, measuring how long signals show a specific level; how long program loops are etc..

Default Set up

The default set up of the analyzers is such that you can switch it on, press the *RUN* key, and immediately get a proper display.

Repetitive Runs

With repetitive runs, the instrument repeatedly captures data until some repeat stop condition is met. The measurement cycle now looks like this:

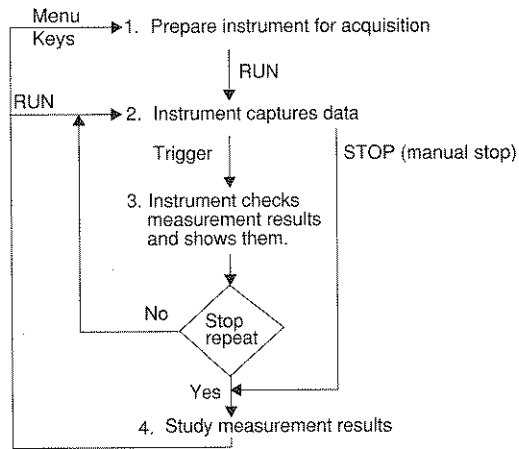

Disk Facilities

Thanks to the disk facilities (accessed via the I/O menu), you can load or store instrument settings and data to shorten the instrument preparation step, or to perform a number of automatic measurements. If you use the autoload feature, the analyzer will automatically load the selected instrument settings from disk at power on time.

Menu Overview

The next two pages show you an overview of the four major menus (CONFIG, FORMAT, TRACE and DISPLAY) used during measurements, with typical entries. Compare the "Dual Analysis Per Pin (DAPP) Mode" in the *PM 3580/PM 3585 Getting Started Guide*.

Manuals

All menus are of the type "fill in the form". Each menu is extensively described in the *PM 3580/PM 3585 Reference Guide*. This guide is organized per menu. Given a menu, it concisely describes per field the purpose of the field and all the possible options.

The *PM 3580/PM 3585 Getting Started Guide* leads you through the different menus by means of a number of examples. In this guide the front and rear panels of the instrument are also described.

This manual, the *PM 3580/PM 3585 User Manual*, gives more background information with respect to the concepts implemented in your instrument. It explains, besides other things, the concepts and possibilities of the State Clock mechanism and sequencer. It also contains a number of more advanced examples. Understanding the background information provided in this manual allows you to get the most out of your instrument.

The *PM 3580/PM 3585 Service Manual* helps you in troubleshooting and repair at module level. It also contains the performance verification procedures for checking out the performance of your instrument.

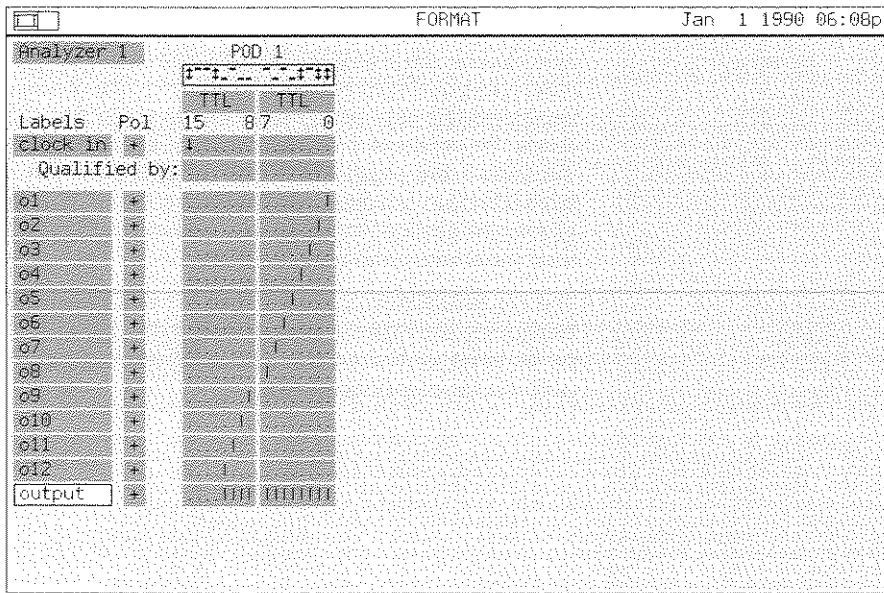
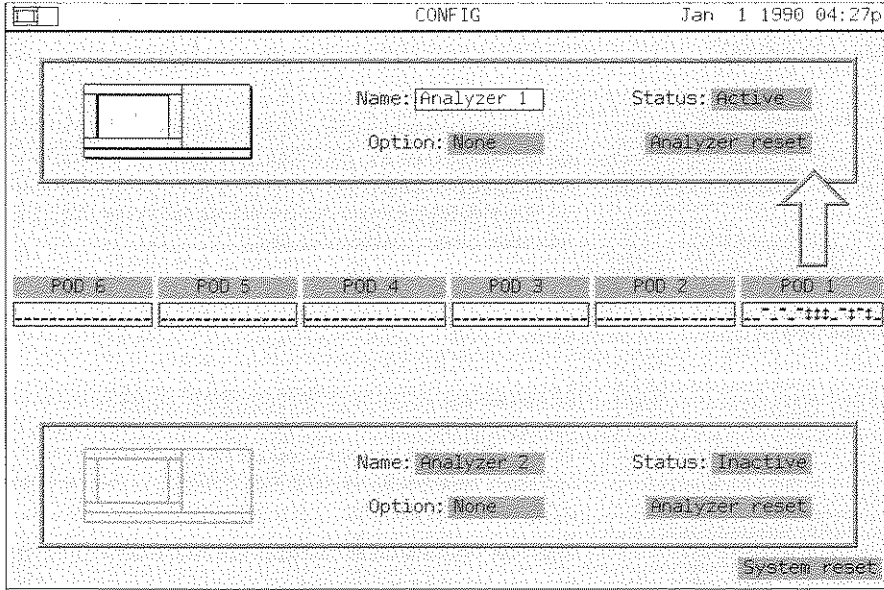

TRACE Jan 1 1990 06:10p

Analyzer 1 Store Anystate

Sequence: L1 If sw1 1 times, Stop trigger BNC

User-defined

Data stored: Timing+State

Trigger pos: Begin

Run mode: Single

Words and Filters

Label: o1 o2 o3 o4 o5 o6 o7 o8 o9 o10 o11 o12 output

Base: +H +H +H +H +H +H +H +H +H +Hex +Hex +Hex +Hex

sw1 clock in 1 1 1 1 1 1 1 1 1 1 1 1 1 fff

DISPLAY Jan 1 1990 06:59p

Analyzer 1 T/div: 50ns X: + 75ns R: + 5ns S: + 100ns Spec.Fncs.

Timing New Y-scale: 1 x Dial: S Mode: Edge R-S: - 95ns Value at S

clock in o1 o2 o3 o4 o5 o6 Level: S

Analyzer 1 Disa: None Y: 0001 R: 0000 S: 0004 Spec.Fncs.

State New Dial: Y Mode: Line R-S: - 290ns

Label	output	Time	clock in	o1	o2	o3	o4	o5	o6	o7	o8	o9	o10	o11	o12
-0002	ffd	- 145ns	✓	1	0	1	1	1	1	1	1	1	1	1	1
-0001	ffe	- 70ns	✓	0	1	1	1	1	1	1	1	1	1	1	1
R	0000	fff	+	0ns	✓	1	1	1	1	1	1	1	1	1	1
Y	0001	f00	+	75ns	✓	0	0	0	0	0	0	0	1	1	1
	0002	001	+	145ns	✓	1	0	0	0	0	0	0	0	0	0
	0003	002	+	220ns	✓	0	1	0	0	0	0	0	0	0	0
S	0004	003	+	290ns	✓	1	1	0	0	0	0	0	0	0	0

Accessories

With your instrument, a number of accessories are supplied as standard. See Chapter 11, "Safety and Installation": "Initial Inspection" for a complete overview of the accessories supplied.

In addition to the standard accessories, a number of additional accessories are available, including, but not limited to:

- Extra pods.
- Extra measuring clips.
- Extra manual sets.
- Instrument cart.
- Microprocessor support packages (adapters and disassembly software).
- Logic target.
- 12 V DC/AC converter for battery operation.

For an up-to-date list of all accessories available, please ask your local Fluke/Philips sales representative.

Switching on the Logic Analyzer

For details see Chapter 11, "Safety and Installation": "Installation".

Note: If you press a key during the analyzer's power on sequence, it will perform a (15-minute) self-test and display the results on the screen. After the self-test has been completed and is satisfactory, the analyzer boots from the floppy disk.

Chapter 2

Overview of the Instrument

Front Panel 2-2
Keyboard 2-3
Rear Panel 2-7

This chapter explains the layout of the instrument. The user interface is described in Chapter 3, "Menu Overview".

Front Panel

The Front Panel of the Logic Analyzer (as shown at the bottom of this page) consists of four areas:

- The display screen on the left displays the menus, operating information, and acquisition results.
- The keyboard in the center and right is used to enter commands.
- The floppy disk drive in the upper right is used for the system floppy disk and for saving and restoring data.
- The pod connectors at the bottom are used to connect the signals to be measured to the analyzer. Each pod connector carries 16 signals. Depending on the channel width of your instrument, you can see two, four or six pod connectors at the bottom of the front panel.

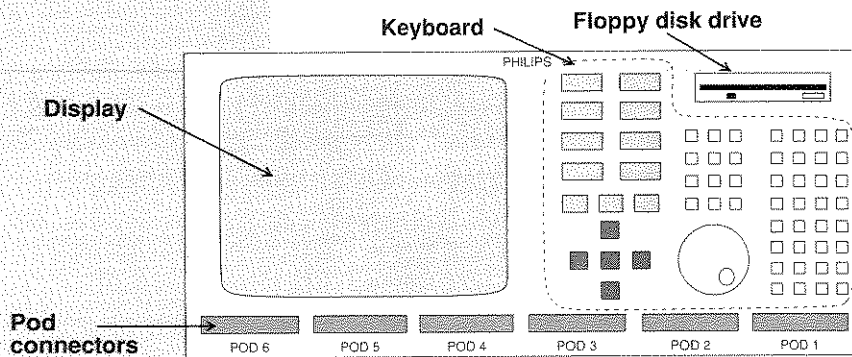

Keyboard

The PM 3580/ PM 3585 Logic Analyzer keyboard is logically grouped into several areas, plus the dial, as shown below. These areas, and the effect of their keys is as follows:

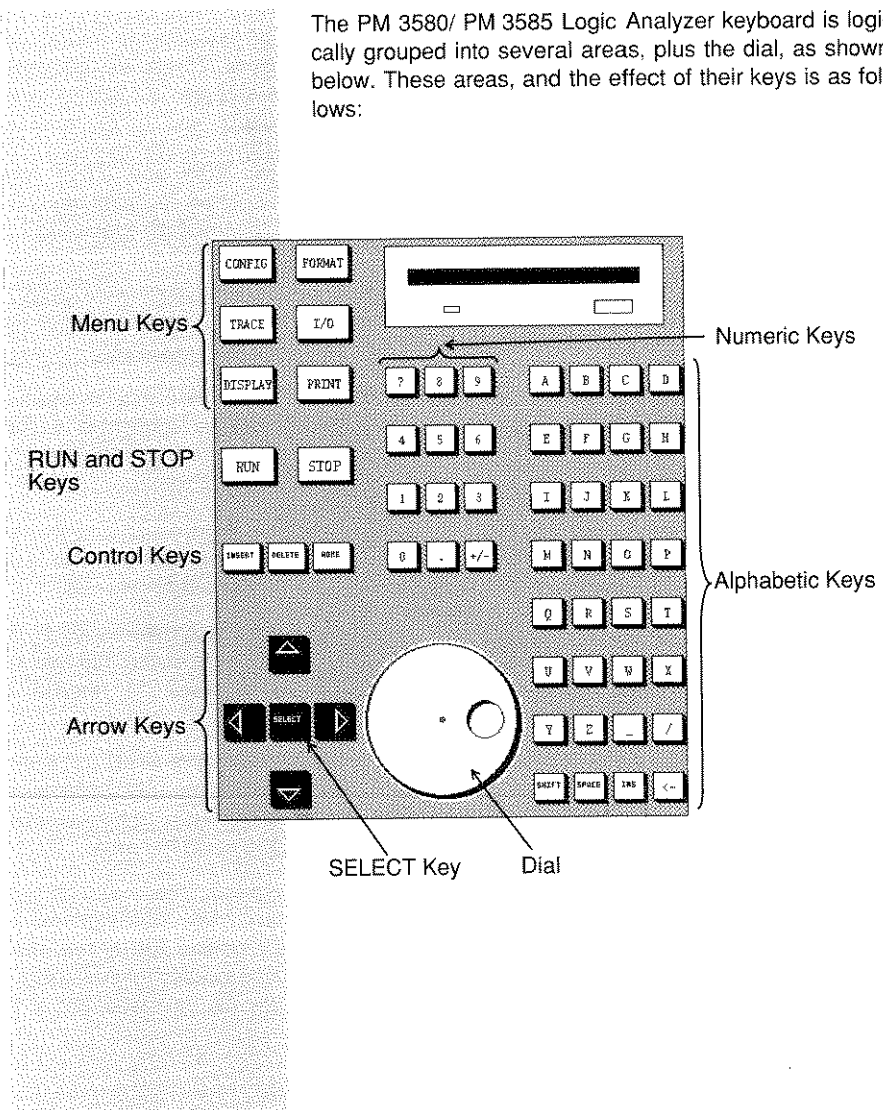

Menu Keys

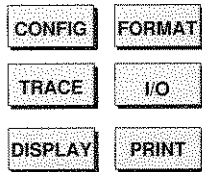

The menu keys select the appropriate major menu.

When you press one of the menu keys (shown at left), the associated menu appears. These are described in Chapter 3, "Menu Overview".

Run and Stop Keys

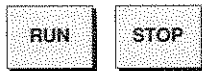

The *RUN* and *STOP* keys are used to manually start and stop data acquisition.

Control Keys



The *INSERT* and *DELETE* keys are used to insert and delete menu items.

The *HOME* key is used to move the highlight to the field at the top left of the menu or screen area.

Arrow Keys and Dial

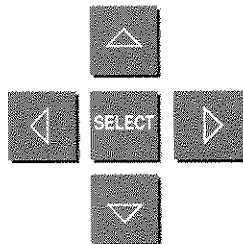

The arrow keys and the dial are used to move the highlight around in menus.

There are differences in the operation of the dial and the arrow keys in relation to *Scrolling*.

When more fields are specified than can be shown in an area, use the arrow keys on the end fields (top and bottom or left and right as appropriate) to scroll the area.

For example, a maximum of eighteen labels can be seen on the Format Menu. If you have more than eighteen labels, moving to any field on the bottom line of the menu and pressing the down arrow key, causes all the labels to move up one line (scroll up), and the next label line to be shown.

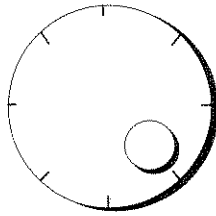

The dial does not perform scrolling; it allows you to wrap around an area, menu, list or popup menu. (These terms are defined in the next chapter.) On the Display menu, however, the dial is used to scroll the data displayed or to move the selected cursor.

Select Key

The *SELECT* key is used to select an action, toggle a value, and to end a numeric entry. (It has a function similar to the Enter or Return key of a computer keyboard.) The specific function of the *SELECT* key is explained in the relevant places.

Numeric Keys

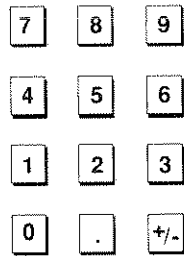

The numeric keys allow the entry of numeric data and numbers within names.

The +/- key can be used to toggle the sign in numeric fields.

Alphabetic Keys

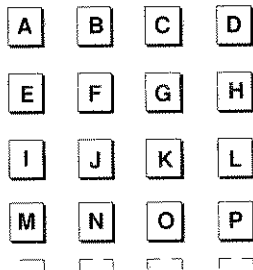

The alphabetic keys are used to rename the analyzer, signals, and files, etc. They can also be used to make quick selections from lists and to define units of measurement.

The alphabetic keys consist of the characters A through Z, the underscore, the forward slash, and the space.

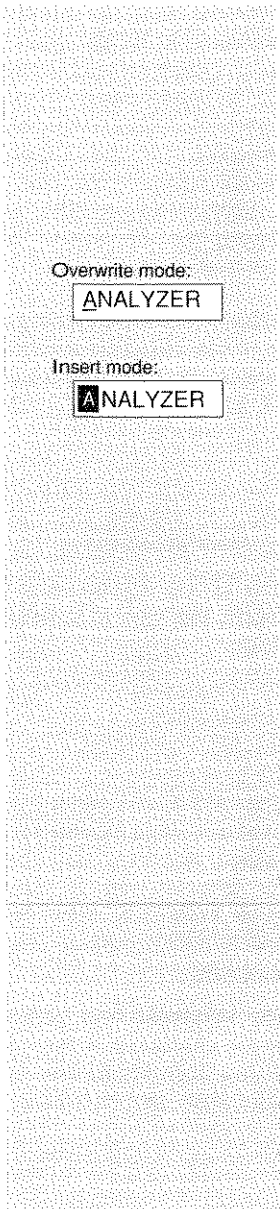

In addition there are three other keys at the bottom of the alphabetic keyboard:

SHIFT: The characters you type are normally lower case. If you press the *SHIFT* key, the next character (and only the next character) will show as upper case. You can also press *SHIFT* and the character key at the same time.

INS: (Insert) Normally when you type, the cursor is an underscore (), and the characters you type overwrite those already present. The *INS* (*INS*ert) key is a toggle that changes the cursor to an invert block and causes characters you type to be inserted in the text. Characters to the right of the cursor are pushed to the right, and if they go beyond the right border they are lost. The insert mode is terminated by pressing the *INS* key again.

← The *BACKSPACE* key () lets you delete the character to the left of the cursor, if there is one, moving up all the characters at the right. This key can also be used in other fields, such as the channel fields, to delete the channel at left.

Rear Panel

The rear panel has all the external connectors (communication interfaces, printer output, video output, trig in and out), the brightness control, power connection and the ON/OFF switch. The illustration at the foot of the page shows the connectors located at the bottom of the rear panel (described from left to right).

- Centronics connector: A female 25-pin 'D' connector for the attachment of a parallel printer with a Centronics interface.
- IEEE connector: optional IEEE-488 (24 pins) connector for remote operation.
- RS232 connector: A male 25-pin 'D' connector for the attachment of a serial mouse.
- TRIG IN connector: A male BNC connector by which a trigger pulse from another instrument can be input to the logic analyzer.
- TRIG OUT connector: A male BNC connector for supplying an external trigger pulse from the Logic Analyzer to another instrument.

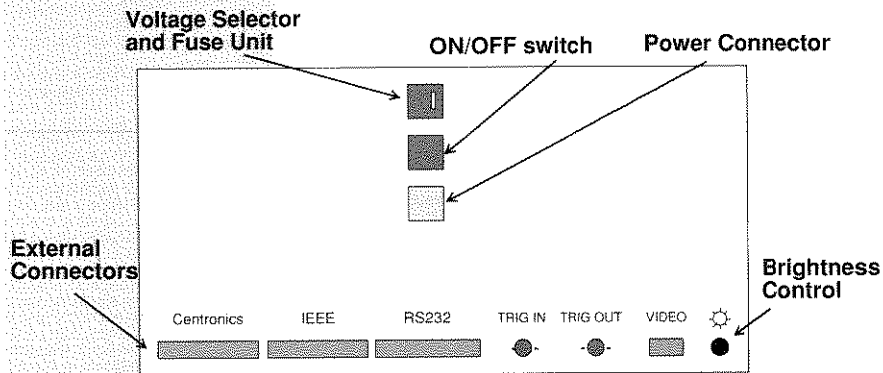

- Video connector: A 15-pin 'D' connector for the attachment of an external 32kHz monochrome monitor (MVGA).
- Brightness control: Increases or decreases brightness level.

In the center top of the rear panel is the voltage selector and fuse unit.

CAUTION

The selected voltage MUST match your line (mains) voltage: otherwise, you can damage the instrument. See the *Installation* procedures described in Chapter 11 for instructions on selecting the correct voltage.

Below the voltage selector and fuse unit is the main instrument ON/OFF switch; below that is the connection for the power cable.

The connector pin specifications can be found in Chapter 9, "User Hardware Specifications".

Chapter 3

Menu Overview

- The Menu 3-2
 - The Menu Bar 3-2
 - Menu Fields 3-3
 - The Analyzer Name Field 3-3
 - Field Types 3-4
- The Configuration Menu 3-6
- The Format Menu 3-8
 - Clock and Label Attributes 3-9
 - The Threshold Level 3-11
 - Polarity 3-12
- The Trace Menu 3-14
 - Run Definition Area 3-15
 - Sequencer Area 3-16
 - Trigger Words Area 3-17
- The Display Menus 3-18
- The Special Functions Popup Menu 3-20
 - Time Origin – T₀ 3-21
- The I/O Menu 3-22
- The Print Menu 3-24

The Menus

This chapter shortly describes the items common to more than one menu, and then the purpose of each menu. Please refer to the *PM 3580/PM 3585 Reference Guide* for detailed information on all fields of the menus, i.e., what a menu, field or option does, or the effect of a key on a field or menu.

The Menu Bar

The five major menus each have a menu bar at the top which provides information about the current status of the instrument, for example as follows.

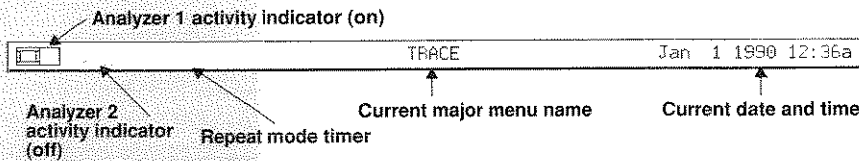

Current Date and Time

In the center of the menu bar is the name of the current menu: CONFIG, FORMAT, TRACE, DISPLAY or I/O.

At the right of the menu bar, the current date and time is displayed. This is especially important when using the Print facility. The date/time information can be changed using the "Set Date and Time" option on the utility disk. See Chapter 12, "Utilities" for instructions on use of the utilities disk.

Analyzer Activity Indicators

At the left of the menu bar are the analyzer activity indicators. There are two such indicators on PM 3585 instruments, and one on PM 3580 instruments.

When an analyzer is active (status = *active* in the Configuration menu) but not running, the appropriate activity indicator is shown in *dark gray*.

When an analyzer is inactive, the appropriate activity indicator is *light gray*. When an analyzer is active and acquiring data, the appropriate activity indicator *flashes*.

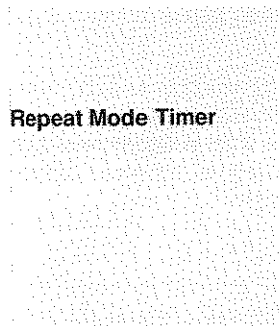

Repeat Mode Timer

On PM 3585 instruments, the left-hand symbol represents analyzer 1, and the right-hand symbol represents analyzer 2.

To the right of the analyzer activity indicators, if the analyzer is in repeat mode (see Chapter 5, "Trace Control"), the repeat mode timer is shown. If auto-repeat is defined but not active, the repeat mode time is *light gray*.

If auto-repeat is defined and active, the repeat mode time is *black and counting down* during the time interval between runs.

Menu Fields

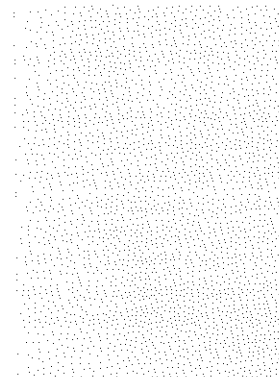

On each menu, there are a number of fields. These are the small white or gray boxes containing text. The currently active field is highlighted: it is the one with a white background. Key press actions only affect highlighted fields. You use the arrow keys or the dial to move the highlight from field to field.

To do something with the instrument, you will select the appropriate menu, highlight the appropriate field, and then press the appropriate key to do the action you want done. (While you are getting to know the instrument, this will most often be the *SELECT* key. You can also think of the *SELECT* key as a kind of help function.)

The Analyzer Name Field

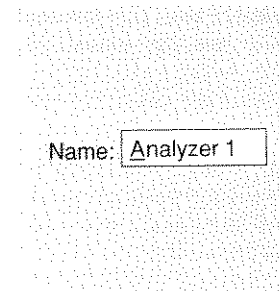

Name:

All the major menus concerning analyzers (*i.e.*, except the I/O menu) contain a field in which the current analyzer name is shown. On the Configuration menu, if you have a PM 3585 instrument, there are two such fields, one for each analyzer.

The default names, used throughout the documentation, are Analyzer 1 and (on PM 3585) Analyzer 2. These names can be changed on the Configuration menu. The

changed name or names will then appear on each of the other menus.

When you press *SELECT* on the Analyzer field (at the top left) on the Format, Trace and Display menus you will see the settings in that menu for the other analyzer. Note that, if no pods are assigned to an analyzer, the menu settings for that analyzer are not selectable.

Field Types

On the different menus, selectable fields are present. Different *types* of field may be distinguished. These field types are described below.

Information:

The data shown in these fields cannot be changed directly.

Editable: These are fields where you specify names of items such as signal and clock labels. You can use all the letter and number keys, including the decimal point, slash (/), space and underscore keys. The *INS* key (right of front panel) toggles between insert and overwrite mode. The dial and left/right arrow keys can be used to move through the field. Use the arrow keys or the *SELECT* key to exit.

Numeric: (Integer and real). These fields are used for entering numeric data. Data is entered in calculator style; each number entered at the right, pushing the other numbers left. Only numeric characters, the backspace key (\leftarrow), the decimal point, and the +/- key are allowed. For integer numbers, the decimal point and +/- keys are ignored. Use of any other key ends the edit mode.

Toggle: On these fields, press *SELECT* to toggle the items cyclically around the predefined values. Where the predefined items are + and -, you can also toggle using the +/- key.

Check: This is a special kind of toggle field. Their pre-defined values are • and ✓. The dot (•) indicates that the item associated with this check field is not selected, the check (✓) that it is selected.

First Character Select:

Press the initial character of one of the options. (The appropriate options are shown in the *Reference Guide*.) Alternatively press *SELECT* to show the list of options.

List: In these fields, the first character selection is not available. Press *SELECT* to show the list of options.

The “▶” symbol after an option on a list indicates that on pressing *SELECT* or the right arrow on the option, a list or popup menu is shown appropriate to the option. When this “child” menu is closed, the “parent” menu is closed too.

Popup Menu:

Press *SELECT* to show a popup menu. The first field of any popup menu, in the *home* position, is the return field. To indicate that all changes have been made on the popup menu and to close the menu, press the *SELECT* or the *HOME* key on this field. The return field is a function field (see below).

Function: When you press *SELECT* on a highlighted function field, the action described by the field is performed.

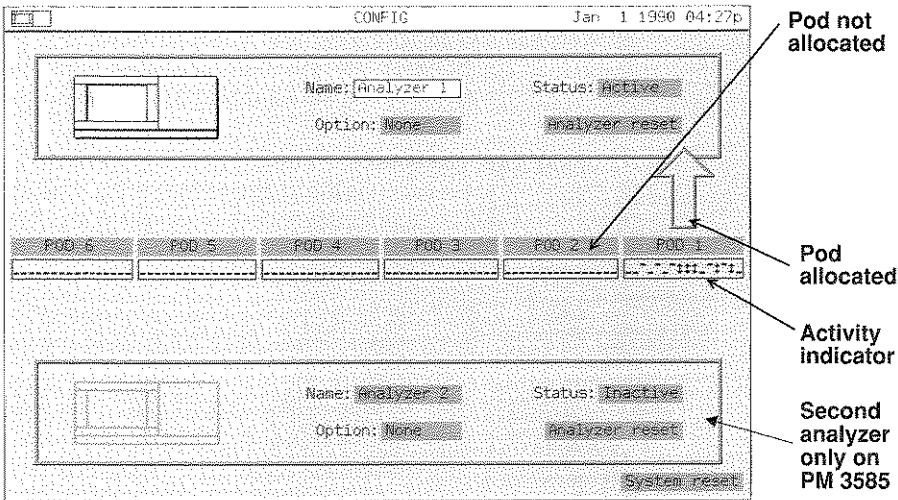

The Configuration Menu

The Configuration menu is normally the first screen shown on start-up. It can be accessed at any time by pressing the *CONFIG* key.

This menu is used to set up the main configuration of a measurement session. Thus assigning the pods to an analyzer and choosing a disassembler.

The options chosen on this screen affect most of the other menus. Note that in the following description, references to the second analyzer are only applicable to PM 3585 instruments.

On this menu you can:

- Change the name of the analyzers (*Analyzer Name* field) as explained in "The Analyzer Name Field" on page 3-3.
- Activate and deactivate either analyzer (*Analyzer Status* field). While an analyzer is inactive, no new data is captured for the pods connected to it.
- Select and load any disassembler that is on the system disk (*Option* field). See Chapter 7, "Disassemblers" for more information.

- Reset either analyzer to its defaults (the *Analyzer Reset* field).
- Assign pods to either analyzer or to neither (the pod assignment arrows). This is done by highlighting the pod you want to assign or deassign and then pressing *SELECT* to toggle the arrow between the two analyzers and none.
Pressing *DELETE* also causes the arrow to disappear.
- See the activity on the pods (the pod activity indicators). These fields (information only) show the current activity of the signals of the associated pod. Activity is high (—), low (—), or changing (‡).
- Reset the instrument to its start-up condition (*System Reset* field). On selection, a confirmation popup menu (Yes/No) is shown. If you select Yes, the system is first reset to the factory preset condition. If there is an auto-load file on the disk, this is then loaded.

Analyzer name field **Clock qualifier selector** **Label selector** **Activity Indicator**

Threshold level **Clock selector**

State Clock definition

Label definition

Clock/label polarity

Analyzer 1	POD 4	POD 3	POD 2	POD 1
Labels	Poi 15 87 0	Poi 15 87 0	Poi 15 87 0	Poi 15 87 0
UDS CLK				
LDS CLK				
Qualified by:				
DCTRL				
FC2_6				
ADDRESS				
DATA				
E7/0N				
BON				
SPN				
HALTN				
BEPPN				
EGACKN				
TP12_ON				
OTACKN				
PCN				
VHAR				

The Format Menu

The primary purpose of the Format menu is to set up the pod thresholds for all assigned pods, to set up the external clocks and their qualifiers, and to set up the labels and polarities for each channel and clock.

Further parameters can be set by the use of popup menus on the clock and label fields. These menus and the features provided by the state clock definition are described in Chapter 4, "State Clocks".

The number of pods shown in this menu depends on the number of pods assigned to the analyzer in the Configuration menu.

Only four pods can be shown at a time in this menu. When more than four pods are associated with an analyzer, the left and right arrow keys can be used on the end fields, as appropriate, to scroll to the other pod or pods.

Clock and Label Attributes

The figure below shows the two popup menus for clock attributes, and label attributes. These popup menus give you access to more advanced parameters (attributes) of clock and data labels. The attribute *Timing label* is discussed below. The other attributes: *Qualifier(s)*, *Display on same line as clock* and *Valid for Clock* are explained in Chapter 4, "State Clocks". The menu for the current signal is popped up by pressing *SELECT* on its label field. By pressing *SELECT* on the Attribute field in this menu, the attributes menu is popped up.

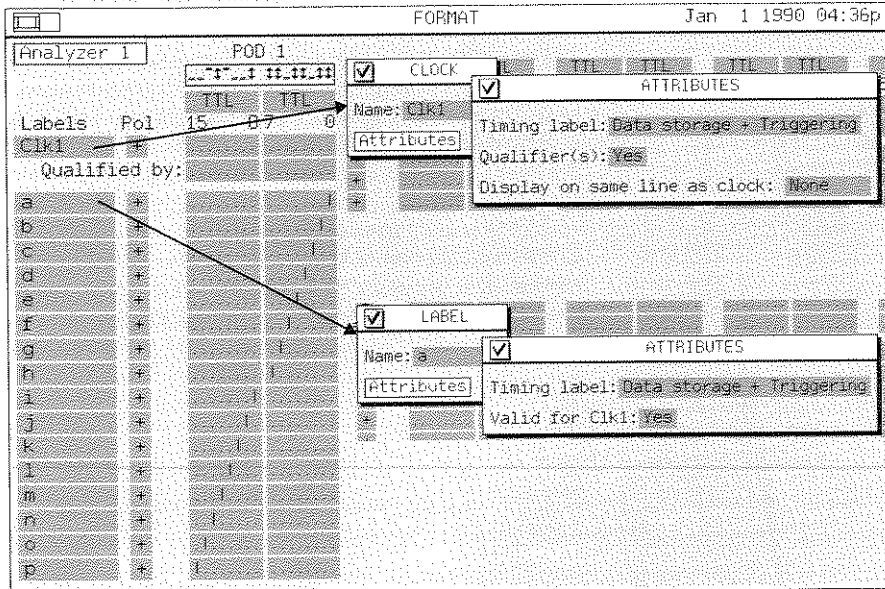

Timing label Attribute

The *Timing label* attribute allows you to switch off timing analysis for a specific label or clock.

Because of the Dual Analysis Per Pin architecture the PM3580/PM3585 Logic Analyzers capture both state and timing data simultaneously for all channels of all pods

assigned to it. Note that timing data is always captured, while state data is captured only if state clocks have been defined. For all labels defined the analyzer by default assumes that the labels are relevant for both timing and state analysis. Furthermore, the analyzer will also capture timing data for the state clocks defined.

However, if you do not want timing analysis for a specific label or clock you can indicate this by setting the Timing label attribute for that label or clock to "No".

If you do want timing analysis for labels and clocks you can set their Timing label attribute to either "Data storage + Triggering" (default) or "Triggering only".

Transitional Timing

With "Triggering only" actual storage of timing data for a label is inhibited. In order to understand and appreciate this "Triggering only" option, you must remember that the PM 3580/PM 3585 Logic Analyzers use transitional timing for storage of timing data. Conventional analyzers store a timing sample on each clock pulse, whether or not the incoming data has changed. This usually means that most of the memory is filled with repeated information. Transitional timing avoids this. A timing sample captured is stored only when there are transitions in the signals. The duration for which that data was valid is stored together with the timing sample in a separate time memory. This allows reconstruction of the timing data in the Timing display.

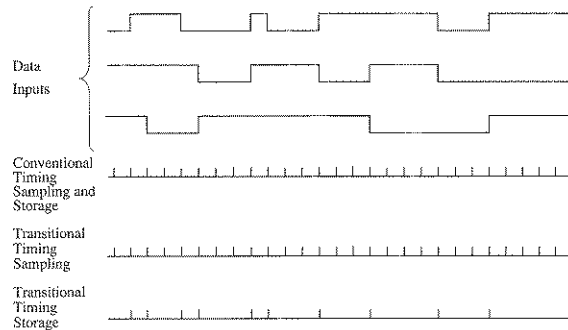

If only one signal would show a lot of transitions (e.g. a clock signal) while others are stable, each transition of that signal still causes a timing sample to be stored, thus filling

memory rapidly. To prevent this, you can selectively switch off data storage for such rapidly changing signals (i.e. inhibit transition detection for these signals). However, you can still specify trigger patterns (on the Trace menu) including conditions for these signals.

The Threshold Level

The analyzer interprets captured data as a logical 1 or 0 depending on whether or not the voltage exceeds the threshold selected in the threshold field.

As all logic analyzers, the PM 3580 and the PM 3585 use a threshold detector on each channel. This is based on a comparator which compares the data input level with a user selectable threshold. Typical thresholds used are TTL (+1.4V) and ECL (-1.3V).

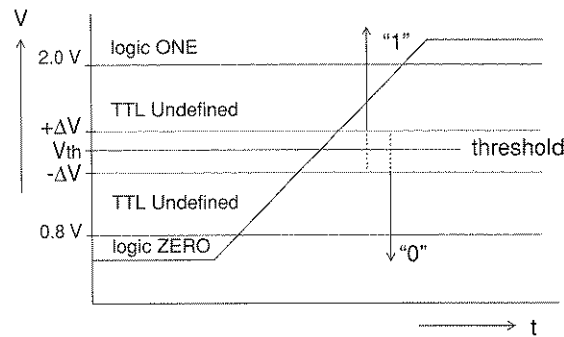

Note that this principle will always result in either a logic ONE or a logic ZERO. Undefined levels are still interpreted as one or the other, depending on their value with respect to the selected threshold.

If you are dealing with a noisy system, using different thresholds will show you how critical the noise on your system is.

Please pay attention to the overdrive required ($+\Delta V / -\Delta V$ in the above figure) with respect to the threshold voltage. A rising edge must pass through $V_{th} + \Delta V$ before it is re-

garded as a ONE. On the other hand, a falling edge must pass through $V_{th} - \Delta V$ before it is regarded as a ZERO.

Thresholds are assigned in groups of eight channels and can be set from -3.0V through +12.0V in steps of 100mV.

Polarity

The *logical* interpretation of the signals not only depends on the threshold, but also on the polarity. The polarity is set for each signal, and by default is positive (+ at the right of the label field). Note that changing the polarity to negative, not only changes the interpretation of 0 and 1 levels, but also that of rising and falling edges:

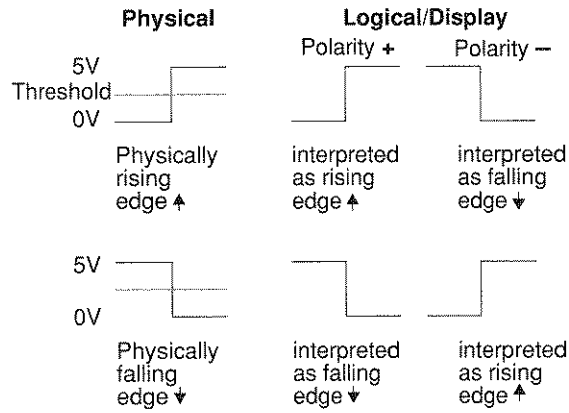

Or in a tabular form:

Physical	Logical	
	+	-
"high"	1	0
"low"	0	1
↑	↑	↓
↓	↓	↑

Note "high" means above threshold, "low" means below threshold

Note, therefore, that if you specify a negative polarity, and trigger on a falling edge (\downarrow), the instrument triggers on a physically rising edge (\uparrow).

Thus if the polarity is toggled (on the Format menu), you will see a corresponding change and adjustment in the trigger words and on the displays.

The screenshot shows the TRACE menu interface. At the top, it displays 'TRACE' and the date/time 'Jan 1 1990 05:21p'. Below this is a menu structure for 'Analyzer 1'. The 'Run Definition' section includes options for 'Sequence: User-defined', 'Data stored: Timing only', 'Trigger pos: Begin', and 'Run mode: Single'. The 'Sequencer' section shows a sequence of events: 'E1 If Timeword 1 times, Stop trigger BNC'. The 'Trigger Words' section is a table with columns for labels o1 through o12 and 'clock in', and rows for 'Base' and 'Timeword'. The 'Base' row shows hex values for o1-o12 and 'clock in'. The 'Timeword' row shows 'x' marks for o1-o12 and 'x' for 'clock in'.

Label:	o1	o2	o3	o4	o5	o6	o7	o8	o9	o10	o11	o12	clock in
Base:	Hex	Hex	Hex	Hex	Hex	Hex	Hex	Hex	Hex	Hex	Hex	Hex	Hex
Timeword:	x	x	x	x	x	x	x	x	x	x	x	x	x

The Trace Menu

The purpose of the Trace menu is to let you define the patterns and sequence of patterns that must be recognized in the data, leading to a triggering of the acquisition hardware.

For state acquisitions, this menu also lets you specify which particular samples should be stored.

In addition, on this menu you can specify what type of data (timing, state, glitch or a combination) should be stored. Also whether you want pre- or post-trigger data, or both, and if a run should be automatically repeated or not.

The different elements controlling data storage and triggering are logically grouped into three areas. Going clockwise, these are Run Definition, Sequencer, and Trigger words, as shown above. Moving between areas is done, as usual, by using the cursor keys. However, by pressing the TRACE key, you can move clockwise to the

last field you selected in each area. The dial moves only within an area.

On first displaying the menu, the cursor (highlighted box) is on the analyzer field in the Run Definition area.

Run Definition Area

In the Run Definition area you can:

- Change between the first and second analyzer on PM 3585 instruments if both analyzers have pods assigned. (The *Analyzer* field.)
- Define the type of sequence to be used in the sequencer area (the *Sequence Type* field). You can choose between predefined sequences (shown at the bottom of the page), user-defined sequences (the default shown on the previous page) and restart sequences. Restart sequences are the same as user-defined, except that the *or if* condition is used as a restart condition. That is, at

TRACE		Jan 1 1990 05:43p																
Analyzer 1	<table border="0"> <tr> <td>Timing sequences</td> <td>State sequences</td> </tr> <tr> <td><input checked="" type="checkbox"/> t_w longer than t_g</td> <td><input checked="" type="checkbox"/> sw_1 then sw_2 then sw_3</td> </tr> <tr> <td><input checked="" type="checkbox"/> t_w shorter or equal than t_g</td> <td><input checked="" type="checkbox"/> sw_1 then sw_2, else sw_3 restrt</td> </tr> <tr> <td><input checked="" type="checkbox"/> $t_7 < \text{Pulse duration} < (t_7+t_8)$</td> <td><input checked="" type="checkbox"/> sw_1 (while storing range)</td> </tr> <tr> <td><input checked="" type="checkbox"/> Edge during $t_w > t_g$</td> <td><input checked="" type="checkbox"/> sw_1 10 times, then sw_2</td> </tr> <tr> <td><input checked="" type="checkbox"/> Glitch during $t_w > t_g$</td> <td><input checked="" type="checkbox"/> sw_1 then immediately sw_2</td> </tr> <tr> <td><input checked="" type="checkbox"/> t_w then Edge; if t_w restart</td> <td><input checked="" type="checkbox"/> 8-bit serial pattern</td> </tr> <tr> <td><input checked="" type="checkbox"/> t_w then Glitch; if t_w restrt</td> <td><input checked="" type="checkbox"/> sw_1 then Edge then sw_2</td> </tr> </table>	Timing sequences	State sequences	<input checked="" type="checkbox"/> t_w longer than t_g	<input checked="" type="checkbox"/> sw_1 then sw_2 then sw_3	<input checked="" type="checkbox"/> t_w shorter or equal than t_g	<input checked="" type="checkbox"/> sw_1 then sw_2 , else sw_3 restrt	<input checked="" type="checkbox"/> $t_7 < \text{Pulse duration} < (t_7+t_8)$	<input checked="" type="checkbox"/> sw_1 (while storing range)	<input checked="" type="checkbox"/> Edge during $t_w > t_g$	<input checked="" type="checkbox"/> sw_1 10 times, then sw_2	<input checked="" type="checkbox"/> Glitch during $t_w > t_g$	<input checked="" type="checkbox"/> sw_1 then immediately sw_2	<input checked="" type="checkbox"/> t_w then Edge; if t_w restart	<input checked="" type="checkbox"/> 8-bit serial pattern	<input checked="" type="checkbox"/> t_w then Glitch; if t_w restrt	<input checked="" type="checkbox"/> sw_1 then Edge then sw_2	<input checked="" type="checkbox"/> Restore last User-defined sequence
Timing sequences	State sequences																	
<input checked="" type="checkbox"/> t_w longer than t_g	<input checked="" type="checkbox"/> sw_1 then sw_2 then sw_3																	
<input checked="" type="checkbox"/> t_w shorter or equal than t_g	<input checked="" type="checkbox"/> sw_1 then sw_2 , else sw_3 restrt																	
<input checked="" type="checkbox"/> $t_7 < \text{Pulse duration} < (t_7+t_8)$	<input checked="" type="checkbox"/> sw_1 (while storing range)																	
<input checked="" type="checkbox"/> Edge during $t_w > t_g$	<input checked="" type="checkbox"/> sw_1 10 times, then sw_2																	
<input checked="" type="checkbox"/> Glitch during $t_w > t_g$	<input checked="" type="checkbox"/> sw_1 then immediately sw_2																	
<input checked="" type="checkbox"/> t_w then Edge; if t_w restart	<input checked="" type="checkbox"/> 8-bit serial pattern																	
<input checked="" type="checkbox"/> t_w then Glitch; if t_w restrt	<input checked="" type="checkbox"/> sw_1 then Edge then sw_2																	
Words and Filters Label: o1 o2 o3 o4 o5 o6 o7 o8 o9 o10 o11 o12 Base: <input checked="" type="checkbox"/> H <input checked="" type="checkbox"/> H <input checked="" type="checkbox"/> H <input checked="" type="checkbox"/> H <input checked="" type="checkbox"/> H <input checked="" type="checkbox"/> H <input checked="" type="checkbox"/> H <input checked="" type="checkbox"/> H <input checked="" type="checkbox"/> H <input checked="" type="checkbox"/> Hex <input checked="" type="checkbox"/> Hex <input checked="" type="checkbox"/> Hex <input checked="" type="checkbox"/> Timedord <input checked="" type="checkbox"/> <input checked="" type="checkbox"/> <input checked="" type="checkbox"/> <input checked="" type="checkbox"/> <input checked="" type="checkbox"/> <input checked="" type="checkbox"/> <input checked="" type="checkbox"/> <input checked="" type="checkbox"/> <input checked="" type="checkbox"/> <input checked="" type="checkbox"/> <input checked="" type="checkbox"/> <input checked="" type="checkbox"/> <input checked="" type="checkbox"/>																		

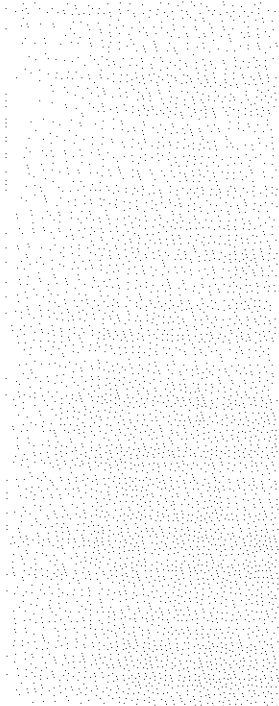

each level it forces the sequencer to go to level 1 if the restart condition occurs. (Thus it *restarts* the sequence.)

- Define the type of data stored (*Type of Data Stored* field). You can choose between storing timing data only, state data only or a combination. You can alternatively choose to store timing and glitch data. This allows you to use the memory available to best effect for the analysis you have to do.

Note that you can also specify, in the sequencer area, that only certain state data is to be stored, and on the Format menu, you can limit timing data storage per label (see Chapter 4, "State Clocks").

Time tags are stored in a separate memory, so the full memory is always available for data.

- Specify the position of the trigger point in data memory (*Trigger Position* field). When acquisition is stopped, a certain percent of the memory contains data that was stored before the trigger point, and the rest of memory contains data that was stored after triggering.
- Set up and define repeating runs (*Run Mode* and *Run Parameters* fields).

Unless otherwise mentioned, all these options are further explained in Chapter 5, "Trace Control".

Sequencer Area

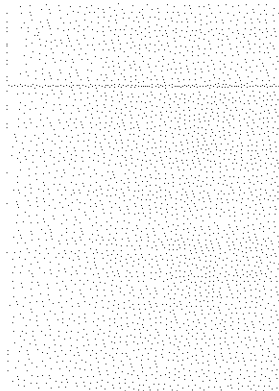

In the sequencer area you define the sequence of events that will cause the analyzer to trigger. You do this either by selecting a predefined sequence and optionally modifying it, or by setting up a user-defined sequence.

You can also have the sequencer trigger state or timing sections separately and send a pulse to the external output (TRIG OUT) or the other analyzer on PM 3585 instruments. It can also react on a pulse from the external input (TRIG IN) or from the other analyzer on PM 3585 instruments.

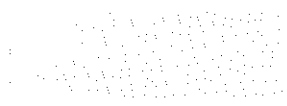

Pattern recognition, sequencer facilities and the pre-defined sequences are all explained in Chapter 5, "Trace Control".

Trigger Words Area

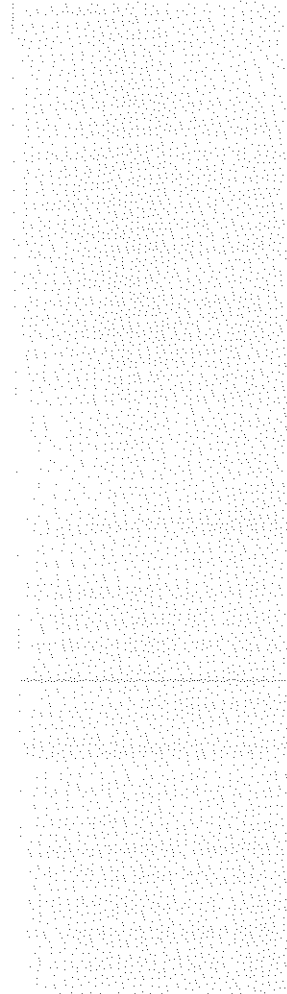

The trigger words area is where you define the patterns that the sequencer is to match on. This is fully explained in Chapter 5, "Trace Control".

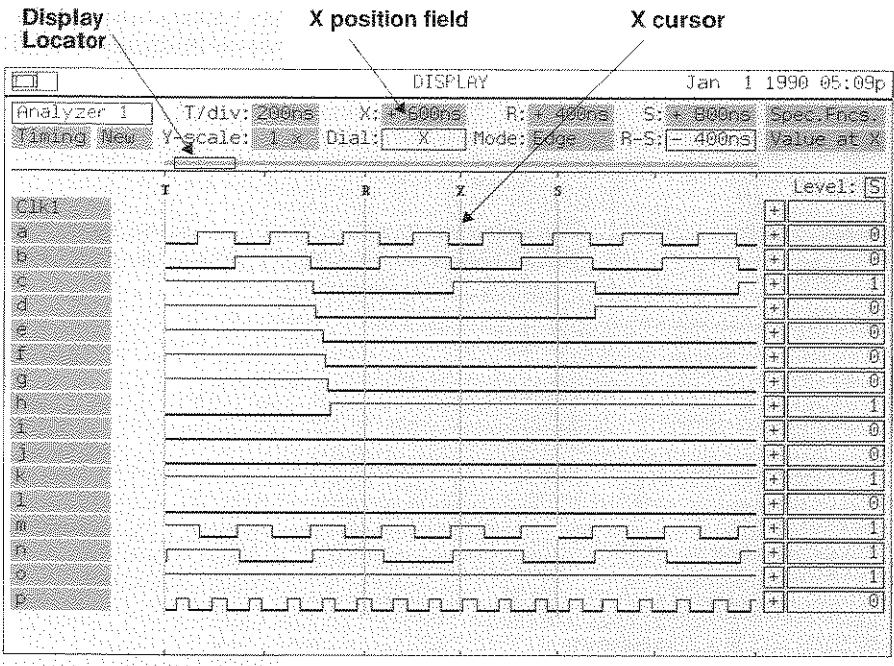

The Display Menus

The display menu can be accessed at any time by pressing the *DISPLAY* key.

The display menu shows the results of an acquisition. Depending on the type of data acquired, the data is shown as either a timing waveform or a state list. The type of data acquired determines the default display format. Subsequently the last displayed format is shown.

The screen consists of one or two equally-sized display windows.

An example waveform screen is shown at the top of this page, and an example state list is shown on the next page. The display menus allow you to examine the results of an acquisition in several ways and thus to analyze the data. The timing waveform can be scaled both horizontally and vertically. Signals can be removed, added (multiply if required), or repositioned.

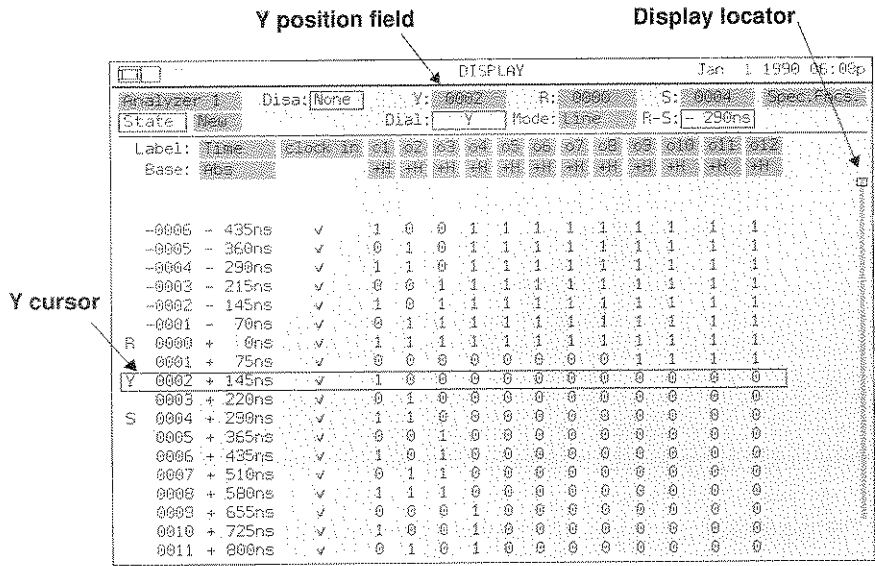

Display Cursors

For timing and state displays, the center-point of the display (the X cursor for timing, and Y cursor for state) can be scrolled with the dial in a number of different modes. Two freely-definable cursors (called R and S cursors) can also be moved independently of the center cursor, also in a number of modes.

Scrolling Modes

The scrolling modes allow quick paging, medium division, or fine step-wise movement through acquisition memory. It also allows movement from one item to the next, where the items are edges, glitches, sequencer levels, compared signal differences or equalities or, on state displays, a defined pattern.

New and Reference Data

On PM 3580 instruments there are two memories: one for newly-acquired data, and one for reference data. PM 3585 instruments have twice as much: two memories for each analyzer.

Both timing and state displays allow you to see either the newly-acquired data or the reference data, or a comparison display. You copy data to the reference memory using the Display Special functions menu, as described below.

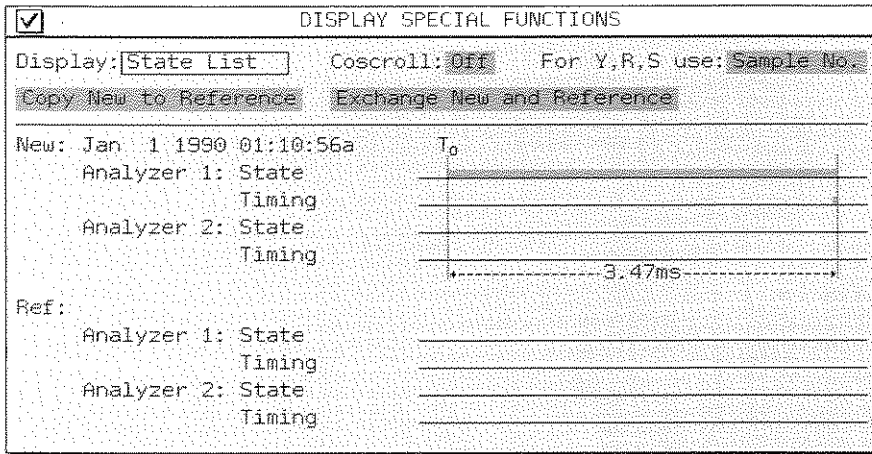

The Special Functions Popup Menu

The Special Functions popup menu shown above is accessed by pressing *SELECT* on the *Display Special Functions* field on any Display menu.

It shows the type of display. It shows the memory usage for newly-acquired and reference data. It also allows you to move new to reference memory and vice versa. Furthermore, it allows synchronized scrolling of split-screen displays, and on state displays, allows cursors to be set by sample number or by time.

The indication of memory usage for newly-acquired data is detailed below. For PM 3580 instruments, Analyzer 2 is not shown. The indication of memory usage for reference data is equivalent.

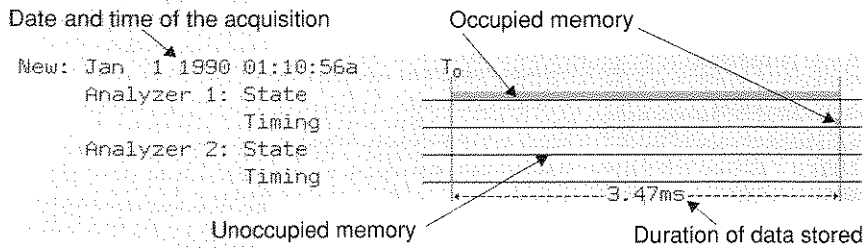

Time Origin – T_0

If there is only one trigger point in memory (*newly* acquired timing *and* state data for *both* Analyzer 1 and 2), then that is taken as T_0 . If there is more than one such trigger point, then that trigger point with the earliest time is the time origin.

In either of these cases, samples occurring *before* T_0 will then have a negative time value associated with them.

If there is no trigger point in memory (the trigger has been lost) then the oldest sample in memory is taken to be T_0 .

For more details, refer to Chapter 6, "Analyzing the Data": "Time Origin - T_0 ".

I/O		Jan 1 1990 07:38p	
Load:	MEAS	Copy	Format
Save:	MEAS	Rename	
Autoload:	MEAS.AUT	Delete	
LABEL:		FREE:	830464
DATE	TIME	FILENAME	SIZE
Jan 1 1990	10:00:20a	SYSTEM	527339
Jan 1 1990	12:00:10p	DEMODISA DIS	45554
Jan 1 1990	06:00:18p	TIMING NEW	8490
Jan 1 1990	06:00:18p	TIMETRIG NEW	8348
Jan 1 1990	06:00:18p	STATE NEW	11568
Jan 1 1990	06:00:18p	DEMODISA NEW	24580

The I/O Menu

The I/O menu has two areas: the command area at the top of the screen, and the file list below.

If there are more files on disk than can be shown, a vertical bar with a display locator (hollow rectangle) is shown at the right of the file list. The position of the display locator indicates which part of the total list of files is currently displayed.

The I/O menu allows you to save and restore newly-acquired and reference data and settings. It also allows you to copy, rename or delete files on floppy disk using the appropriate function of the command area. You can also format (initialize) new floppy disks.

The *Autoload* field allows you to change the name of the auto-load file. The auto-load file, if defined, is automatically loaded when the instrument is powered on. The auto-load file can be any file created by saving a measurement with the save command.

Notes:

1. If a measurement is saved, all data and instrument settings are saved together in one file having a name you specify. Settings and data cannot be saved separately. If a measurement is loaded, all data and instrument settings contained in the file specified, are loaded. Settings and data cannot be loaded separately.
2. To copy complete disks you can use the "copy disk" utility on the utility disk delivered with your instrument. For details refer to Chapter 12, "Utilities".
3. Because the file format is MS-DOS compatible, you can also use your PC to copy, rename or delete files, or to format new disks if your PC is equipped with an appropriate floppy disk drive. (See Chapter 9, "User Hardware Specifications" for more details.)

The Print Menu

The Print menu is a popup menu as shown below. It allows you to print the current screen on a printer or to a file on disk.

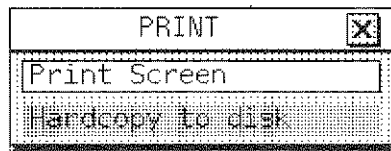

The *Print Screen* field causes the current screen (without the print popup menu) to be printed on a dot-matrix printer attached to the Centronics connector.

During a printout, the operation can be stopped by pressing any key on the instrument. A confirmation screen appears; if you respond "no", do not stop, the printout continues, otherwise it is aborted.

You can cancel the print operation after popping up this menu by selecting the *Cancel* field (the 'X' at the top right). This removes the popup menu and returns with no further action.

Selecting the *Hardcopy to disk* field copies the current screen (without the print popup menu) to a file on the floppy disk called SCREEN.HC. You can rename this file using the rename function of the I/O menu. The format of this file is specified in Chapter 10, "File Formats".

Chapter 4

State Clocks

- Sampling of State Data 4-2
 - Example 4-2
 - Specifying State Clocks 4-2
- Clock Qualification 4-3
 - Example 4-5
 - Specifying Clock Qualifiers 4-5
- Multiple Clocks 4-6
 - Example 4-6
 - Maximum Number of Clocks and Qualifiers 4-8
- Label Attributes 4-9
 - Valid for Clock 4-9
 - Timing Label 4-11
 - Default Values 4-11
- Clock Attributes 4-12
 - Display on Same Line as 4-12
 - Qualifier(s) 4-13
 - Timing Label 4-14
 - Default Values 4-14
- Multiplexed Busses 4-14
 - Example 4-15

Sampling of State Data

In order to sample state data, the analyzer uses a clock signal derived from the system under test. This signal must clock the analyzer when the state data is valid. The clocking of state data is thus synchronous with the system under test.

The PM 3580/PM 3585 instruments can use any channel as a clock and also any channel as a qualifier for a clock.

Example

As an example consider a 12-stage binary ripple counter controlled by a clock signal: clock-in.

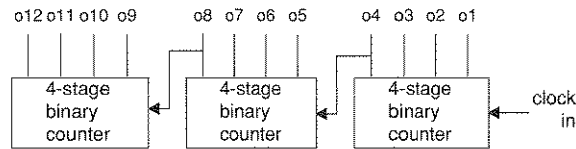

On each falling edge of the clock-in signal the outputs change, incrementing the binary number they represent.

To check the proper functioning of the counter state analysis can be used. Each new value of the counter should be measured by the analyzer. To do this the falling edge of the clock-in signal can be used by the analyzer as a state clock.

Specifying State Clocks

The specification of state clocks is done on the Format menu in the State clock definition area. *The PM 3580/PM 3585 Reference Guide* extensively describes how to set up and modify the menu. The set up of the Format menu for our example is shown on the next page.

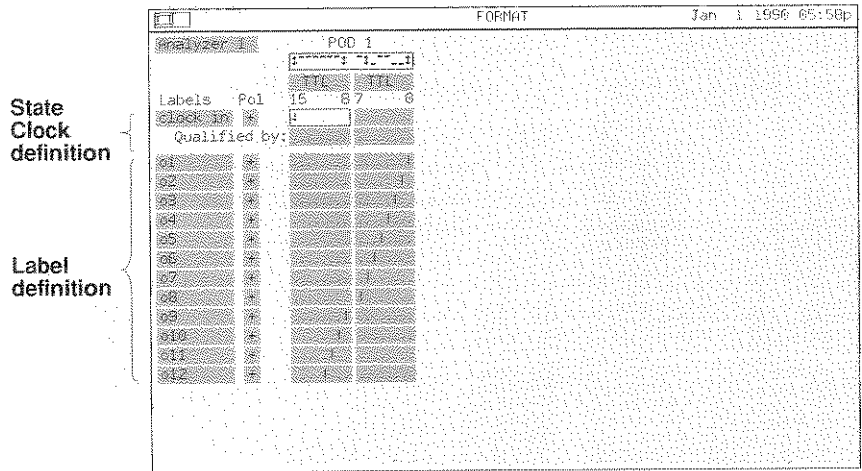

Clock Qualification

Clock-qualifiers allow you to selectively enable clock pulses on the wanted sample instants to avoid irrelevant data in the Logic Analyzer memory and on the screen.

Figure (a) on the next page shows a timing diagram indicating the Analyzer sample instants derived from the external clock shown on the upper line in this figure. The same data is sampled more than once by the analyzer. It is assumed that the falling edge of the clock was selected for data sampling.

Figure (b) shows the Analyzer sample instants derived from the same external clock. This clock is now qualified by a separate signal. In this diagram, the clock is enabled if the qualifier signal is high. The same data is now only sampled once by the analyzer.

The resulting state clock expression for the Logic Analyzer is thus:

$$\text{State Clock} = \text{Ext. Clock} \downarrow \cdot \text{Qualifier} \overline{}$$

Note: The arrow after the clock signal indicates the edge to be used by the analyzer. The level symbol ($\overline{}$) indicates the level of the qualifier signal to be used by the analyzer.

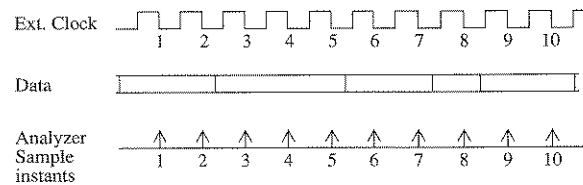

(a) State clock not qualified

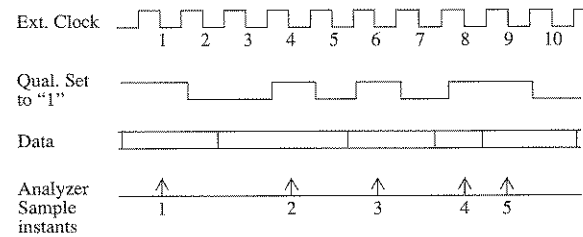

(b) State clock qualified

Example

A 12-stage binary counter is controlled by two signals: a clock signal (clock-in) and a active high count enable signal (enable). The clock is running continuously, however, the outputs of the counter will only change if the count enable signal is active (high).

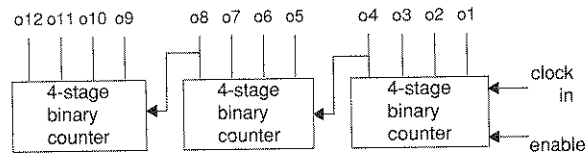

If the clock signal is used by the analyzer without further qualification, a large number of equivalent samples may result, depending on the activity of the count enable signal.

Qualification of the clock signal by means of the count enable signal will result in a clock for the analyzer which is only active if the count enable signal is active (high). This prevents the analyzer from sampling the same counter value repeatedly.

The state clock expression for the Logic Analyzer should thus be:

$$\text{State Clock} = \text{clock in} \downarrow \cdot \text{enable} \text{ —}$$

Specifying Clock Qualifiers

The specification of clock qualifiers is also done on the Format menu in the State clock definition area. For our example this is shown on the next page.

State
Clock
definition

Label
definition

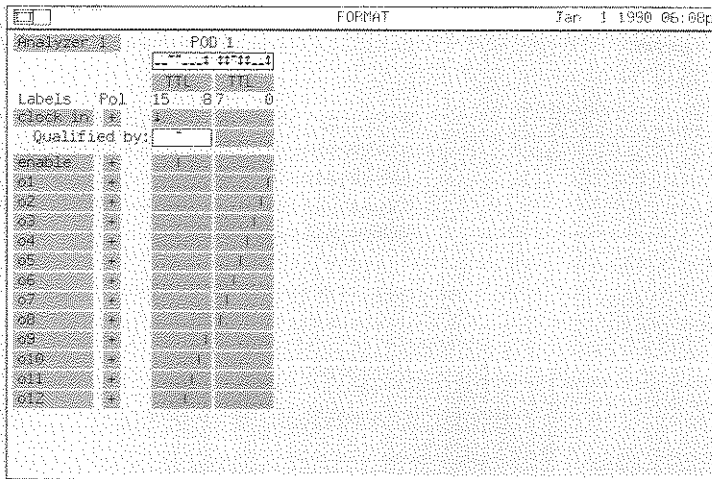

Multiple Clocks

When measuring more complex synchronous systems, such as for example microprocessors, more than one clock may be required for the analyzer to capture all the relevant state information. Specifically for microprocessor address and data busses, strobe signals validate the address or data on the busses. The strobe signals can be used by the analyzer to capture the status of the microprocessor busses on well defined instants.

Example

As an example consider Motorola's 68000. This microprocessor uses two control lines, the Upper Data Strobe (UDSN¹) and Lower Data Strobe (LDSN¹) to validate the

1. The overline on the signal names (active low) in the data sheets of the microprocessor are replaced in this document, and on the Logic Analyzer screen, by an additional "N" as last character of the signal name.

For example: \overline{UDS} = UDSN.

transfer of a word or byte over the data bus. In order to capture all data transfers both strobe signals must be used as external clocks for the Logic Analyzer.

The UDSN and LDSN signal are only meaningful (i.e. indicate a bus transfer to or from the microprocessor) if the microprocessor has control over the busses. This is indicated by the status of the Bus Grant Acknowledge signal (BGACKN) of the microprocessor. In order to capture only meaningful states of the processor's busses the UDSN and LDSN signals should therefore be qualified by the BGACKN signal of the microprocessor.

The state clock expression for the Logic Analyzer should thus be:

$$\text{State Clock} = \text{UDSN} \uparrow \cdot \text{BGACKN}^- + \text{LDSN} \uparrow \cdot \text{BGACKN}^-$$

This expression can be defined on the Format menu in the State clock definition area as shown below.

		FORMAT								Jan 1 1990 02:07p	
Analyzer 1		POB 4		POB 3		POB 2		POB 1			
Labels Pol		TTL	TTL	TTL	TTL	TTL	TTL	TTL	TTL		
UDSN_CLK	*										
Qualified by:											
LDSN_CLK	*										
Qualified by:											
DSCTRL	*										
FC2_Lo	*										
ADDRESS	*										
DATA	*										
R/WM	*										
BGN	*										
ERN	*										
HALTN	*										
BERRN	*										
BGACKN	*										
IFLZ_EN	*										
DTACKEN	*										
ASN	*										
WMEN	*										

Maximum Number of Clocks and Qualifiers

A maximum of four clocks and four clock-qualifier expressions can be defined simultaneously per analyzer. Any of the available channels may be selected as a clock or clock-qualifier. A clock may be qualified by any or all (ORed) of the four qualifier expressions. A given qualifier expression, however, may be assigned to only one clock. A channel assigned to a clock cannot be assigned to a data label.

Notes:

1. For each clock, you may independently select the rising, falling or either edge of the signal to be used.
2. A clock always uses a qualifier expression, even if the expression is empty and not shown (see "Qualifier(s)" on page 4-13).
3. The maximum state clock frequency for the PM 3580/PM 3585 Logic Analyzers is 50 MHz. That is: for the clocks specified, the edges used should be at least 20 ns apart. When clock edges are less than 40 ns apart, these clocks should be assigned within one pod.

You may thus also build complex state clock expressions like for example:

$$\text{State Clock} = \text{Clk1} \uparrow \cdot (S_1 \text{---} \cdot S_3 \text{---} + S_4 \text{---}) + \text{Clk2} \downarrow \cdot S_2 \text{---}$$

On the Format menu this expression looks like:

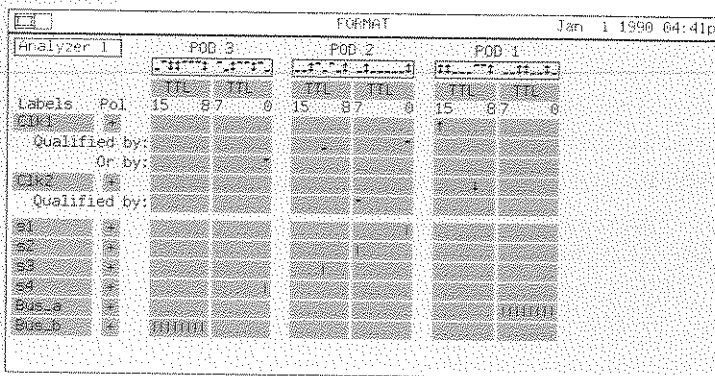

Label Attributes

When an external clock occurs, the Logic Analyzer takes a sample of all the signals of all the pods assigned to that analyzer.

If more than one external clock is defined it may, however, be that only some signals are valid for one clock while other signals are valid for another clock. For example, sometimes it is needed for a microprocessor to use one clock at which only the address lines are valid and another clock for which only the data lines are valid. In order to get a proper display of the data captured the analyzer should only display the values sampled for those signals which were actually valid for the clock which caused the sample to be captured. For that it is necessary to tell the analyzer which signals are actually valid for which clock.

Label Attributes Menu

This can be done by means of *label attributes* which can be defined in the label attributes menu. This menu is accessed by pressing *SELECT* on the label field in the Format menu. The menu for the label is then popped up. By pressing *SELECT* on the *Attribute* field in this menu, the attributes menu is popped up (compare, Chapter 3, "Menu Overview": "Clock and Label Attributes".)

<input checked="" type="checkbox"/>	ATTRIBUTES
Timing label: Data storage + Triggering	
Valid for Clk1: Yes	

Valid for Clock

In the *Valid for Clki* field it can be specified whether a label is valid or invalid for that specific clock.

On displaying the state data the analyzer will show the samples in the order they were captured, with one sample

per line. A line on the state display thus relates to a sample captured by an external clock. If more than one external clock was defined the lines will thus show the samples captured by the different external clocks in the order in which these clocks occurred.

If a label is valid for a specific clock than data captured for that label is displayed in the Display menu on lines which show the data captured by that clock. If the label is not valid for a specific clock the data captured for that label is not displayed in the Display menu on the line which shows the data captured by that clock.

For example assume addresses are valid for Clk1 and data is valid for another clock, Clk2, and both clocks are alternating. The resulting display would than be:

Label:	ADDRESS	DATA	CLK1	CLK2
Base:	+Hex	+Hex		
0000	02e8		✓	
0001		fe	✓	✓
0002	02e9		✓	
0003		20	✓	✓
0004	02ea		✓	
0005		7e	✓	✓
R 0006	20fe		✓	
0007		80	✓	✓
0008	02eb		✓	
0009		b7	✓	✓
Y 0010	02ec		✓	
S 0011		f2	✓	✓
0012	02ed		✓	
0013		f3	✓	✓
0014	02ef		✓	
0015		fb	✓	✓
0016	02f0		✓	
0017		c3	✓	✓
0018	02f1		✓	
0019		e7	✓	✓

Sample number

Note that the tick (✓) on a line indicates that the data on that line was captured with the clock for which the tick is shown.

The fact that labels can be specified to be valid for one or more specific state clocks only, also influences the specification of state words. For more details refer to Chapter 5, "Trace Control": "State Pattern Recognizers".

Timing Label

The other attribute found on the label attributes menu is *Timing label*. The purpose of this attribute is extensively described in Chapter 3, "Menu Overview": "Clock and Label Attributes".

Default Values

When you insert a new label, the attributes for this label are set to their default values, i.e.:

Timing label : Data Storage + Triggering

Valid for Clki : Yes (for all clocks)

Specifically note that if a new clock (e.g. Clkx) is inserted, the *Valid for Clkx* attribute for all labels already defined is set to "Yes".

Clock Attributes

As was discussed previously the analyzer will display each sample on a new line. If, however, samples captured by different clocks logically belong to each other it is useful to display these samples on the same line. As an example assume again a microprocessor with two separate signals indicating respectively the validity of the address lines and data lines. The data transferred goes to (write) or comes from (read) the address captured before.

Clock Attributes Menu

You can force the analyzer to display state samples of different clocks on one line using the *clock attributes* which are defined in the Clock attributes menu.

The menu for a clock is popped up by pressing *SELECT* on its label field. By pressing *SELECT* on the *Attribute* field in this menu, the attributes menu is popped up. (Compare, Chapter 3, "Menu Overview": "Clock and Label Attributes").

<input checked="" type="checkbox"/>	ATTRIBUTES
Timing label:	Data storage + Triggering
Qualifier(s):	yes
Display on same line as clock:	None

Display on Same Line as

In the *Display on same line as* field it can be specified whether the samples captured with this clock should be displayed on the same line as the samples captured by another clock.

The analyzer will display the samples captured by this clock on the same line as the samples captured by the clock specified in the *Display on same line as* field if that clock occurred just before this one.

For example, if you specify for Clk2, as defined in the previous example, display on same line as Clk1, the resulting display is:

Analyzer 1		Disa: Off	Y: 0010	R: 0006	S: 0010	Spec. Fncs.
State	New	Parameters	Dial: Y	Mode: Line	R-S: -3005ns	
Label:	ADDRESS	DATA	CLK1	CLK2		
Base:	+Hex	+HEX				
-0002	02e7	21	✓	✓		
0000	02e8	fe	✓	✓		
0002	02e9	20	✓	✓		
0004	02ea	7e	✓	✓		
R 0006	20fe	80	✓	✓		
0008	02eb	b7	✓	✓		
Y 0010	02ec	f2	✓	✓		
0012	02ed	f3	✓	✓		
0014	02ef	fb	✓	✓		
0016	02f0	c3	✓	✓		
0018	02f1	e7	✓	✓		
0020	02f2	02	✓	✓		
0022	02e7	21	✓	✓		
0024	02e8	fe	✓	✓		
0026	02e9	20	✓	✓		
0028	02ea	7e	✓	✓		

Sample number

Notes:

1. Two or more ticks (✓) on one line indicate that the samples on that line result from different clocks.
2. The sample number (or time value) displayed on a line containing more than one tick (✓) is that of the "first clock", that is of the clock specified in the *display* on same line as field.

Qualifier(s)

If a state clock does not require separate qualification, the *Qualified by* line on the Format menu is empty and thus actually irrelevant to show. You can therefore switch off the



display of this line by specifying "No" for the Qualifier(s) attribute. This then leaves room for an extra line to display labels. To again display the Qualified by line on the Format menu you should set the Qualifier(s) attribute to "Yes".

Timing Label



The purpose of the *Timing label* attribute is extensively described in Chapter 3, "Menu Overview": "Clock and Label Attributes".

Default Values

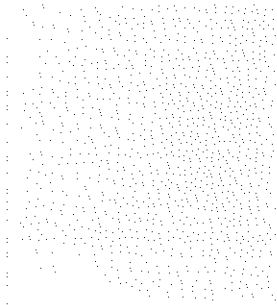

When you insert a new clock, the attributes for this clock are set to their default values, i.e.:

- Timing label* : Data Storage + Triggering
- Qualifier(s)* : Yes
- Display on same line as clock* : None

Specifically note that the label attribute *Valid for Clock*, referring to this new clock is set to "Yes" for all labels already defined.

Multiplexed Busses

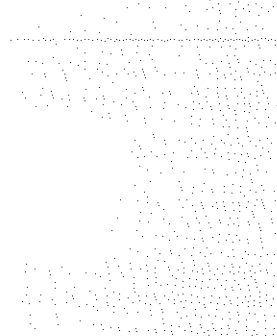

When you measure multiplexed busses, it is necessary to define three different labels for the same bus. One label is specifically used in relation to timing analysis. The name for this label is best chosen such that it reflects the multiplexed character of the bus.

The two other labels are specifically used in relation to state analysis. The names for these labels are best chosen such that they reflect the separated meaning of the bus.

The reason for these different labels can best be explained by means of an example.

Example

Consider the 8085 microprocessor from Intel. This processor has a multiplexed address/data bus where the least significant address lines are multiplexed with the data bus.

The timing diagram for a read cycle is shown below:

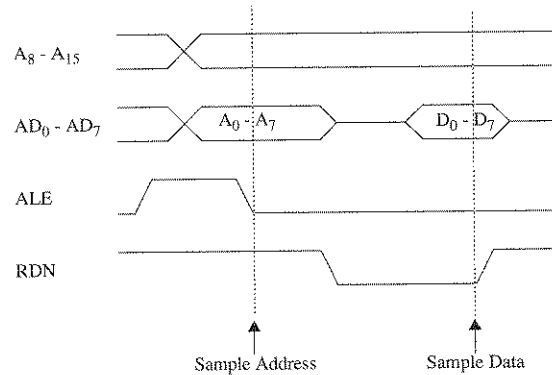

The timing diagram for a write cycle and interrupt acknowledge cycle are equivalent.

The multiplexed address/data lines ($AD_0 - AD_7$) contain a stable address on the falling edge of the ALE signal. This signal should therefore be used to clock the address signals.

The address/data lines contain stable data on the rising edge of the RDN, WRN or INTAN signals as appropriate for the data transfer cycle. These signals should therefore be used to clock the data signals into the analyzer.

The four clock signals (ALE, RDN, WRN and INTAN) are only meaningful (i.e. indicate a bus transfer to or from the microprocessor) if the microprocessor has control over the busses. This is indicated by the status of the Hold Acknowledge signal (HLDA) of the microprocessor. In order to capture only meaningful states of the processor's busses, the four clock signals should therefore be qualified by the HLDA signal of the microprocessor.

The state clock expression for the Logic Analyzer should thus be:

$$\text{State Clock} = \text{ALE} \downarrow \cdot \text{HLDA} _ + \text{RDN} \uparrow \cdot \text{HLDA} _ + \text{WRN} \uparrow \cdot \text{HLDA} _ + \text{INTAN} \uparrow \cdot \text{HLDA} _$$

The Format menu as set by the 8085 disassembly software is shown below.

Labels	Pol	POD 3				POD 2				POD 1			
		TTL	TTL			TTL	TTL			TTL	TTL		
ALE	+	15	8	7	0	15	8	7	0	15	8	7	0
Qualified by:													
RDN	+												
Qualified by:													
WRN	+												
Qualified by:													
INTAN	+												
Qualified by:													
STATUS	+												
ADDRESS	+												
DATA	+												
A15_8	+												
A7_0	+												
HLDA	+												
HOLD	+												
S0	+												
S1	+												
IO/MN	+												

For state analysis, three labels: "STATUS", "ADDRESS" (A0 - A15) and "DATA" (D0 - D7) are defined, with:

"STATUS" valid for ALE but not for RDN, WRN or INTAN.

"ADDRESS" valid for ALE but not for RDN, WRN or INTAN.

"DATA" valid for RDN, WRN and INTAN but not for ALE.

If the labels "ADDRESS" and "DATA" as defined above were used in a timing display, the result would be:

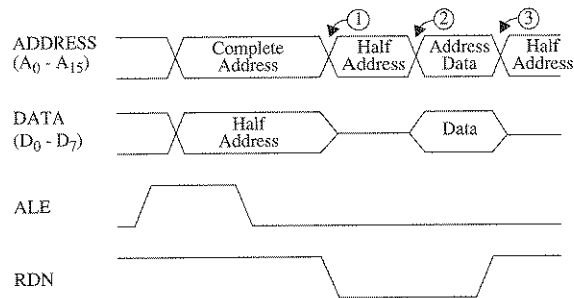

Where, for each of the indicated time instants, signal changes occur in the label "ADDRESS" for the following reasons:

1. "ADDRESS" changes because the multiplexed address/data bus changes from address to floating.
2. "ADDRESS" changes because the multiplexed address/data bus changes from floating to data.
3. "ADDRESS" changes because the multiplexed address/data bus changes from data to floating.

For the label "DATA", half of the address and all data would be shown. Although this is correct, the label name "DATA" would not properly reflect this.

The timing display would thus be very confusing. It is therefore necessary to explicitly tell the analyzer that the labels "ADDRESS" and "DATA" are to be used for state analysis only. Two other labels "AD7_0" and "A15_8" should be specified, and used for timing analysis only.

The Timing label attribute for the labels "ADDRESS" and "DATA" should thus be set to "No".

The Timing label attribute for the labels "AD7_0" and "A15_8" should be set to "Yes", i.e., "Data storage + Triggering".

For these last two labels it should be specified that they are not valid for any of the state clocks; i.e., Valid for ALE, RDN, WRN, INTAN = "No".

The following table summarizes the attributes for all the labels of the 8085 as set by the setup files provided with the

adapter for this microprocessor (refer to Chapter 7, "Disassemblers" and Chapter 8, "Probing"):

Label	Timing label	Valid for			
		ALE	RDN	WRN	INTAN
STATUS	No	Yes	No	No	No
ADDRESS	No	Yes	No	No	No
DATA	No	No	Yes	Yes	Yes
A15_8	DS+T*	No	No	No	No
AD7_0	DS+T*	No	No	No	No
HLDA	DS+T*	No	No	No	No
HOLD	DS+T*	No	Yes	Yes	Yes
S0	DS+T*	No	No	No	No
:					
SOD	DS+T*	No	No	No	No

* DS+T = Data Storage + Triggering.

With the labels and their attributes defined as above, the resulting display of timing data and state data looks as shown below. This was produced by simultaneous acquisition of timing and state data made possible by the Dual Analysis Per Pin architecture.

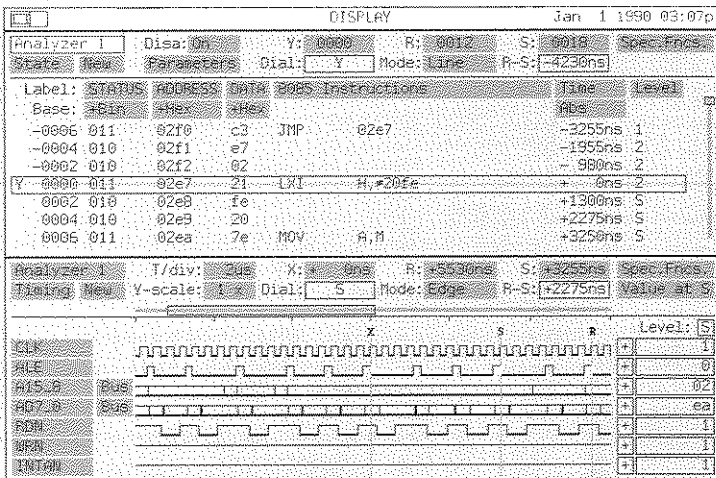

Chapter 5

Trace Control

- Trace Control Features 5-3
 - Kind of Data Stored 5-4
 - Triggering 5-5
 - Trigger Point Position 5-5
- Pattern Recognition 5-7
- Timing Pattern Recognizers 5-7
 - Timing Words 5-7
 - Timing Pattern Duration 5-7
 - Glitch Detector 5-8
 - Edge Detector 5-9
- State Pattern Recognizers 5-10
 - State Words 5-10
 - Not State Words 5-11
 - Immediate State Words 5-11
 - Range Detector 5-12
 - Not in Range Detector 5-15
 - State Clocks 5-15
- Combinations of Pattern Recognizers 5-16
- Specifying Patterns for Recognition 5-17
 - Recognizer Fields 5-17
 - Value Entry 5-20
 - Overlapping Labels 5-21
 - Ranges 5-21
- Sequencer Facilities 5-22
 - Level Structure 5-23
 - Creating a Level 5-24
 - Time-Out Value 5-25
- Restart Sequence 5-26
- Examples 5-26
 - Program Flow 5-26
 - Interrupt Response Time 5-28
 - Check Minimum Pulse Width 5-29
 - Check Maximum Pulse Width 5-29
 - Check Pulse Duration 5-30
 - Check Pattern Sequence 5-31
 - Wait for a Pattern Sequence 5-31
 - One Immediate Sequence of Two Patterns 5-32
 - Two Immediate Sequences of Two Patterns 5-33

PM 3580/PM 3585 User Manual

Separately Trigger State and Timing 5-34
Predefined Sequences 5-35
 The Predefined Timing Sequences 5-36
 The Predefined State Sequences 5-37
 Last User-defined Sequence 5-38
Repetitive Measurements 5-39
 Starting Repetitive Measurements 5-39
 Terminating Repetitive Measurements 5-39
 Repeat Mode Timer 5-41

Trace Control Features

Using the trace control features provided by your PM 3580/PM 3585 Logic Analyzer gives you full control over the acquisition process of the instrument.

Basically you can control:

- What kind of data should be stored.
- When data acquisition should stop (triggering).
- What the trigger position should be.
- Whether a run should be automatically repeated or not.

All trace features are combined in the Trace menu.

The screenshot shows the 'TRACE' menu interface. At the top right, it displays 'Jan 1 1990 05:21p'. The main menu area contains the following options:

- Analyzer 1
- Sequence: User-defined
- Data stored: Timing only
- Trigger pos: Begin
- Run mode: Single
- Run parameters

Below this is the 'Words and Filters' section, which includes a table of bit positions and their bases:

Label:	o1	o2	o3	o4	o5	o6	o7	o8	o9	o10	o11	o12	clock in
Base:	+H	+H	+H	+H	+H	+H	+H	+H	+H	+Hex	+Hex	+Hex	+Hex
Timelord	X	X	X	X	X	X	X	X	X	X	X	X	X

Annotations with arrows point to 'Run Definition' (the top section), 'Sequencer' (the 'Run mode' and 'Run parameters' options), and 'Trigger Words' (the 'Timelord' row in the table).

The PM 3580/PM3585 Reference Guide describes extensively how to set up and modify the menu. This chapter provides the background information for the menu.

Kind of Data Stored

The Dual Analysis Per Pin architecture allows your analyzer to store any one of the following types of data:

- Timing data only.
- Timing and glitch data simultaneously.
- Timing and state data simultaneously.
- State data only.

The kind of data that is to be stored is specified in the *Data stored* field on the Trace menu.

If state data is to be stored ("Timing and State Data" or "State Only") you can further instruct the analyzer to store specific data samples only, before the trigger point. You do this by use of the sequencer's selective data storage feature (see "Sequencer Facilities" beginning on page 5-22).

One of the options for the *Data stored* field is "Auto". If this option is selected the analyzer will automatically select which types of data are stored, as follows:

- Timing + State if external clocks are defined.
- Timing + Glitch if a predefined option including glitch is selected.
- Timing only otherwise.

In the *Data stored* field it is then shown what the analyzer selected.

If you set the *Data stored* field to a specific option, for example "Timing + State", the automatic selection mechanism of the analyzer is inhibited until you select the "Auto" option again.

"Auto" is the default setting for the *Data stored* field.

Note: "Auto" in *Data stored* field

Triggering

Triggering of the logic analyzer is based on the recognition of a sequence of one or more specific data patterns in the data captured by the analyzer. Your logic analyzer has built-in a number of pattern recognizers (trigger words) for recognition of state and timing patterns (see "Pattern Recognition" beginning on page 5-7). Patterns can be specified in the Trigger words area of the Trace menu.

Thanks to the Dual Analysis Per Pin architecture, the analyzer can search for state and timing patterns in parallel. Both state and timing patterns can be specified within one single sequence (see "Sequencer Facilities" beginning on page 5-22).

Trigger Point Position

Considering the data stored during a run, two periods can be distinguished: that before the trigger point, and that after the trigger point. The diagram below shows this graphically.

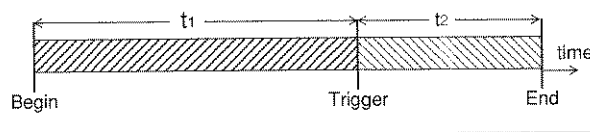

You define by the sequence what the conditions must be for the trigger to occur, and by the Trigger Position, the relationship between t_1 and t_2 .

Pre-trigger Period

During the pre-trigger period t_1 , data is stored and a sequence of data patterns is searched for. If the sequence is not found before the memory fills, old data is pushed from memory, and new data inserted so the newest data is always available. When the sequence is found, the hardware is triggered.

Post-trigger Period

During the post-trigger period t_2 , data is stored for the amount of time, or to fill the percentage of memory specified, then acquisition is stopped.

Trigger Pos. Field

The position of the trigger point can be specified in the *Trigger pos* field. The default trigger point position is at the beginning of memory, so that only post-trigger data is stored.

User-defined Option

The User-defined option allows you to set the trigger position exactly where you want it. Furthermore, if you specify that timing and state data is to be stored, you can set up different amounts of post-trigger fills for each section if you want.

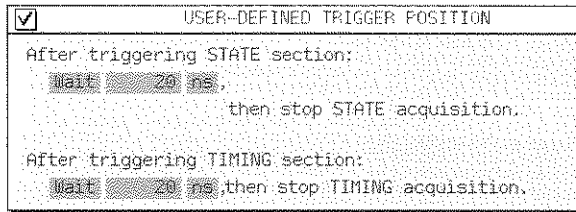

In addition, using more advanced options of the sequencer, you can set independent trigger points for the timing and the state section. This is described in "Sequencer Facilities" beginning on page 5-22.

You can set the trigger position so that acquisition stops following a specific time delay, or after a specified percent of memory is filled. For state data you can also specify that the analyzer stops after a given number of samples has been acquired.

Pattern Recognition

For timing pattern recognition, the following recognizers are available:

- One timing word.
- Two filter words.
- One glitch detector.
- One edge detector.

For state pattern recognition, the available recognizers are:

- Eight state words.
- One range detector.

Each of these recognizers is described below.

Timing Pattern Recognizers

Timing Words

Each timing word is the AND combination of bit (0,1 or x) patterns in each label.

Three timing words are available per analyzer:

TimeWord: If specified, all timing samples captured are compared against the TimeWord.

tw₇,tw₈: If specified, all timing samples captured at 20 ns intervals are compared against tw₇ or tw₈ or both.

Note: tw₇ and tw₈ may alternatively be used as state words sw₇ and sw₈ respectively.

Timing Pattern Duration

For timing words tw₇ and tw₈, a pattern duration (filter) can be specified, allowing recognition of patterns which are present for more than or less than a specified time period.

The time period can be specified in a range from 20 ns to 1.31 ms in steps of 20 ns.

Time periods can be specified for tw_7 and tw_8 independently. It can be seen in the diagram below, when the pattern duration conditions $tw_i > t_i$ and $tw_i \leq t_i$ are true or false:

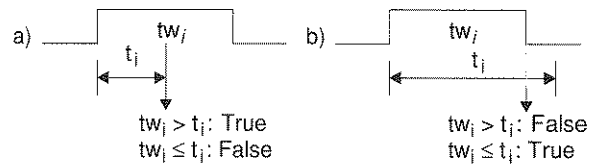

Glitch Detector

A pulse is recognized as a glitch if its width is less than 6ns and the pulse was not normally sampled. To be sure of detection, the glitch signal must exist for at least 3ns.

When a glitch is specified on more than one channel, the analyzer logically ORs them together. That is, a glitch pattern is found when a glitch occurs on at least one of the channels you specified.

The analyzer may be programmed to look for an isolated glitch, or for one during a pattern which has been present for at least a specified time. In the latter case, this is defined as:

Glitch during ($tw_i > t_i$) ($i = 7$ or 8)

This condition is true if a glitch as specified occurs after time interval t_i , but before or at the moment when tw_i becomes false. That is, if a glitch as specified occurs within the time interval t_g shown below:

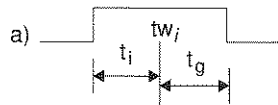

Notes:

1. If glitch triggering is specified for a channel for which the timing label attribute is set to "Triggering only", this attribute is overruled. That is, timing data will then also be stored for this channel, as long as the *Data Stored* field specifies that timing data is to be stored.

2. If glitch triggering is specified and the *Data Stored* field specifies that glitch data should be stored (*i.e.*, "Timing + Glitch"), then glitch data is only stored for those channels for which glitch triggering is specified. If glitch triggering is not specified, but the *Data Stored* field indicates that glitch data should be stored, then glitch data is stored for all channels.

Edge Detector

You can specify a rising edge (↑), a falling edge (↓) or either edge (‡) per channel. When an edge is specified on more than one channel, the analyzer logically ORs them together. That is, an edge pattern is found when an edge occurs on at least one of the channels you specified.

The analyzer may be programmed to look for an isolated edge, or for one during a pattern which has been present for at least a specified time. In the latter case, this is defined as:

Edge during ($tw_i > t_i$) ($i = 7$ or 8)

This condition is true if any edge specified occurs after time interval t_i , but before or at the moment when tw_i becomes false. That is, if any edge specified occurs within the time interval t_e shown below:



Note that glitch and edge patterns may be specified together in combination with a pattern duration, that is:

(Glitch or Edge) during ($tw_i > t_i$).

Note: The PM 3580/30 and PM 3580/60 instruments store data sampled at 100 MHz. However, edge detection in these units operates at 200 MHz. Consequently, if a pulse occurs which is smaller than the minimum detectable pulse for these units, triggering on the edge of such a pulse may occur, even if that pulse data is not stored.

State Pattern Recognizers

State Words

Each state word is the AND combination of bit (0,1 or x) patterns in each label.

Eight state words are available per analyzer labeled sw₁ through sw₈ (sw₇ and sw₈ may alternatively be used as timing pattern recognizers tw₇ and tw₈).

State words can be used to detect the occurrence of specific patterns in the state data captured.

Labels can be specified to be valid for one or more specific state clocks only (see Chapter 4, "State Clocks": "Label Attributes"). Consequently, to detect specific patterns for these labels, only those state samples captured with a clock for which the label is valid should be compared against the state word. It is therefore important that it is specified for which state clock a state word is valid. This is done in the *clock* fields of the Trace menu's Trigger Words area (see "Specifying Patterns for Recognition" beginning on page 5-17).

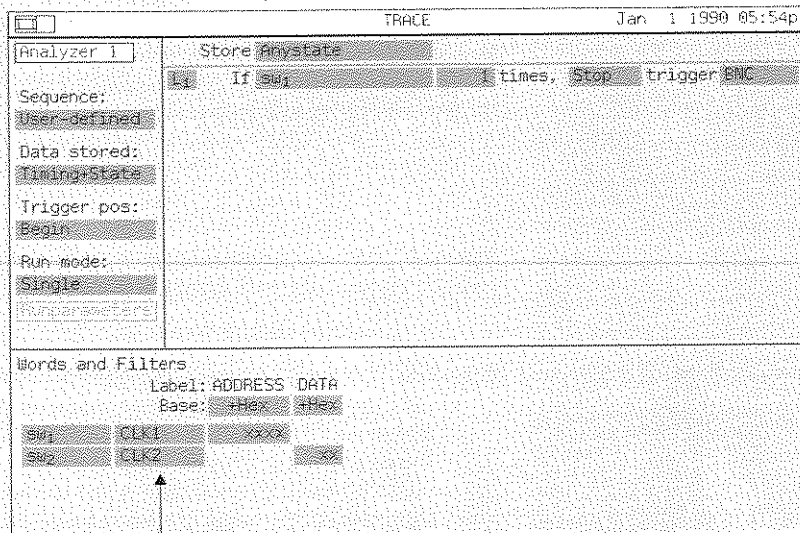

Clock fields

Not State Words

Not state words are the same as state words, except that they are true if the sample captured *does not* match the state word specified.

Immediate State Words

State words may be combined into immediate word pairs labeled sw_{12} , sw_{34} , sw_{56} , sw_{78} . An immediate word pair sw_{xy} reveals a true condition if the state words sw_x and sw_y are recognized in two consecutive state samples, with sw_x being the first recognized.

Applications

Applications which require the use of immediate state words are given in the examples "One Immediate Sequence of Two Patterns" on page 5-32 and "Two Immediate Sequences of Two Patterns" on page 5-33.

Multiplexed Busses

Immediate state words are also useful in analyzing multiplexed busses. As an example, consider a multiplexed address/data bus where the address is valid for Clk1, and the data is valid for Clk2. Recognition of an address/data combination in this case requires two state words, one to recognize the address, and the other the recognize the data. If sw_1 and sw_2 are programmed to be valid for Clk1 and Clk2 respectively, the immediate word pair sw_{12} may be used to recognize an address/data combination on the multiplexed address/data bus.

Note that for this particular example, the use of an immediate word pair is practical, but not absolutely necessary. The detection of the address/data combination could also be done by using two levels of the sequencer. The first level then looks for the occurrence of sw_1 , the next level for the occurrence of sw_2 and if sw_2 does not occur, jumps back to the first level to look for sw_1 again.

Range Detector

The range detector evaluates the range expression which is the AND combination of individual label ranges. A label's range identifies that label's data which is numerically between or on two specified patterns (i.e. Range Low ≤ label's data ≤ Range High). These patterns are a combination of bit (0, 1 or x) patterns in a label.

This advanced range detection allows your analyzer to detect, for example a range of data in a range of addresses, i.e.:

$$\text{Range expression} = (\text{Address in address range}) \& (\text{Data in data range})$$

State Clock Validity

As for state words, you should specify for which state clock the range expression is valid. This is done in the *clock* field of the Trace menu's Trigger Words area. In all the examples below, it is assumed that labels defined are valid for the same state clock.

Label Ranges

A range can always be defined for a label which:

- Has its channels assigned in no more than two pods. These pods, however, do not need to be physically adjacent.
- Does not share pods with other labels for which a range has been defined.

This is shown below:

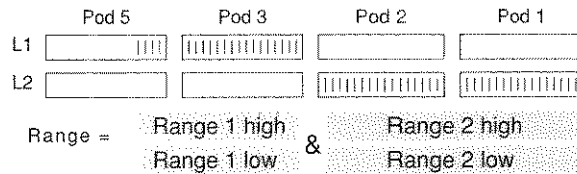

The remainder of this section deals with other situations.

Number of Pods Per Label

If a label has channels assigned within more than two pods, a range can still be defined for that label. In the example below, label L32 has 32 channels assigned: 4 within pod 5, 8 within pod 3, 16 within pod 2, and 4 within pod 1.

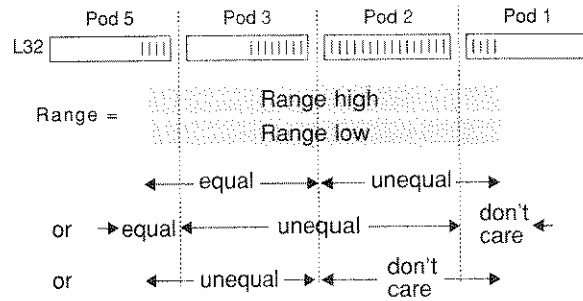

Note: Pod 4 not used by L32.

If a range is specified for L32 where range high and low for the channels of pods 2 and 1 differ, then the values for range high and low must be equal for the channels of pods 5 and 3. Alternatively, set pod 1 as don't care and the range can then be specified over pods 2 and 3. (Lose accuracy to extend range.) The values for range high and low must then be equal for the channels of pod 5. Similarly, if all channels of both pods 2 and 1 are set to don't care, a range may be specified for both pods 5 and 3.

Multiple Labels

When two or more labels share a pod, then, at any one time, only one of those labels can have a range specified for it. The label for which the range is specified is freely selectable.

The example below shows which range expressions can be defined for two different labels which share a pod:

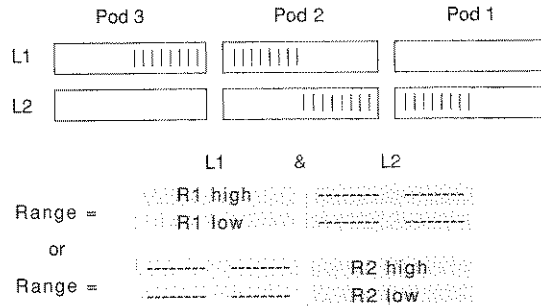

Equal Pattern

Since pod 2 is shared by labels L1 and L2, only one of these labels can have a range specified for it. When a range may not be specified for a label, this is indicated by '-'. In the range expression, these '-'s are interpreted as don't cares for that label.

When a label shares a pod with another label for which a range was specified, then a pattern can be specified for it with the range high and low values equal. Provided that:

- Such a label has all its channels assigned within that pod only.
- None of these channels is also assigned to the label for which the range is defined.
- The channel numbers for all these channels are higher than the highest numbered channel for which the label's range was specified.

In the following example, in the second range expression, label L3 is such a label.

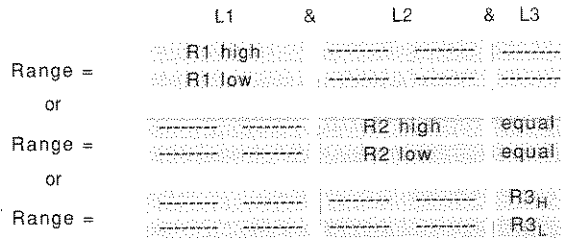
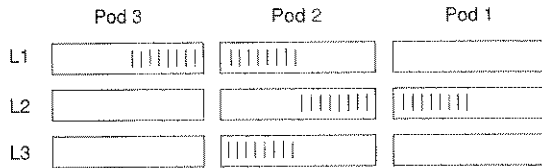

Consistency Check

When you specify a range value for a label, the software checks for consistency with the existing range definitions for other labels when you exit the edit field. If any inconsistency is detected, you are notified via a popup menu, and you can select how the software resolves the inconsistency. You have a choice of:

- undoing the last value entered,
- updating this label only (RangeH = RangeL),
- updating all other labels as necessary.

Note that the second option is shown only if such an action can resolve the inconsistency.

Not in Range Detector

The "Not in range detector" is the inverted output of the range detector. So for example:

$$\overline{\text{Range}} = \text{not } \{ (\text{Address in address range}) \cdot (\text{Data in data range}) \}$$

$$= (\text{Address in address range}) + (\text{Data in data range})$$

Not in range identifies label data which is numerically neither between nor on two specified patterns RangeH and RangeL.

Note that not in range is only evaluated for the state samples captured with the state clock specified for the range in the Trace menu's Trigger Words area.

State Clocks

State Clocks may also be used as patterns themselves for both triggering as well as storage qualification. When state clocks are referred to, the edge definition and clock qualification as specified in the Format menu is used.

Combinations of Pattern Recognizers

All the timing pattern recognizers described above can be combined into complex timing trigger conditions. For example:

TimeWord + Glitch during ($tw_8 > t_g$)

This expression is true if either the TimeWord occurs, or a glitch occurs while pattern tw_8 is present for at least time period t_g .

All the state pattern recognizers described above can be combined into complex state trigger, or store, conditions. For example:

$Clk1 + sw_2 + \overline{sw_4} \cdot \overline{sw_5}$

This expression is true if either Clk1 occurs, or sw_2 occurs, or neither sw_4 nor sw_5 occurs.

Specifying Patterns for Recognition

The patterns you want to be recognized by the analyzer during acquisition are specified in the Trigger Words area of the Trace menu.

Recognizer Fields

A row in this area represents a pattern recognizer. Pattern recognizers are automatically added to the Trigger Words area as predefined sequences are selected or conditions are specified in the Sequencer area. You can also insert and delete pattern recognizers in the Trigger Words area by pressing the *INSERT* or *DELETE* key respectively on any field of a row representing a pattern recognizer.

The screenshot shows the TRACE menu interface. At the top, it says 'TRACE' and 'Jan 1 1990 11:50a'. Below that, 'Analyzer 1' is selected. The configuration for 'Store Anystate' is shown, including a sequence: 'If timeword 1 times, Stop trigger ENC'. The 'Data stored' is 'Timing+State', 'Trigger pos' is 'Begin', and 'Run mode' is 'Single'. Below this is a table titled 'Words and Filters'.

	Label: CLK1	Label 1	Label 2	Label 3	Label 4	Label 5	Label 6
Base:	Bin	Hex	Hex	Hex	Hex	Hex	Hex
Timeword		xx	xx	xxxxxxx	xx	xx	xx
dur	20 ns	x	xx	xxxxxxxx	xx	xx	x
swi	CLK1	xx	xx	xxxxxxxx	xx	xx	xx

↑ Name of Pattern Recognizer
 ↑ Clock Used/Filter Time
 Pattern fields

When a new pattern recognizer is inserted, the data pattern for that recognizer contains x's (don't cares). When a pattern recognizer is deleted, it is removed from the display. However, the data pattern which was specified for that recognizer remains intact and will be recalled when the pattern recognizer is inserted again.

First Field of a Row

The *first field* of a row contains the name of the pattern recognizer.

Second Field of a Row

The meaning of the *second field* of the row depends on the type of recognizer:

TimeWord, Glitch, Edge: second field not present.

tw₇, tw₈: second field is used to specify the filter time.

sw₁ .. sw₈, Range: second field is used to specify the state clock for which the state word or range is valid.

Pattern Fields

The following fields, called *pattern fields*, are used to specify label values which should be recognized.

The label names are displayed above the pattern fields. Directly below the name of the label is a *Base* field which allows you to specify the number base in which the label's values are shown and entered. The + or - character in the *Base* field reflects the polarity of the label set in the Format menu. It is for information only and cannot be changed here. All labels defined on the Format menu are shown in the Trigger Words area and in the same order.

Scrolling Labels and Pattern Fields

If more labels are present than can be shown, the labels and pattern fields can be scrolled. Moving to the last *Base* field or last pattern field of a row at the right hand side of the Trigger words area and pressing the right arrow key, causes the whole pattern area to move left, and the next label to be shown. Moving left to the first pattern field of a row or to the first label *Base* field and pressing the left arrow key causes the whole pattern area to move right, and the previous label to be shown.

Presence of Pattern Fields

A pattern field for a specific label is present in the row of a pattern recognizer only if the label has the proper attributes, *i.e.*:

Timing Pattern Recognizers:

A pattern field is present for a label if the label attribute "Timing label" is set to "Data storage + Triggering" or "Triggering only".

State Pattern Recognizers:

A pattern field is present for a label if the label is valid for the state clock for which the state recognizer is valid.

In the Trace menu shown below an example is given of a possible appearance of the Trigger Words area. In this example the labels have the following attributes:

	Timing Label	Valid for	
		Clk1	Clk2
Label 1	Yes*	No	Yes
Label 2	Yes*	Yes	No
Label 3	No	Yes	No
Label 4	Yes*	Yes	Yes
Label 5	Yes*	No	No

* Either "Data storage + Triggering" or "Triggering only".

TRACE
Jan 1 1990 11:54a

Analyzer 1 Store Anystate

Sequence: If Timelord 1 times, Stop trigger ENC

User-defined

Data stored: Timing+State

Trigger pos: Begin

Run mode: Single

Run parameters

Words and Filters

	Label: Clk1	Clk2	Label 1	Label 2	Label 3	Label 4	Label 5
Base:	+Bin	+Bin	+Hex	+Hex	+Hex	+Hex	+Hex
Timelord		x	x	xx	xx		xx
Td1	20 ns	x	x	xx	xx		xx
Sw1	Clk1				xx	xxxxxxx	xx
Sw2	Clk2		xx				xx

Value Entry

The pattern fields are editable fields in which you can enter the required value.

Using the *Base* field you can select another number base in which the label's values are shown and entered. If a value can not be represented in the currently selected base a '?' is shown for those digits which can not be represented. Values for Glitch and Edge pattern recognizers can only be specified in the binary base. This base is automatically selected when the Glitch and/or Edge pattern recognizer is specified.

Note that you can simply set all fields of a pattern recognizer to 0's, 1's or x's using the Set Trigger Word popup menu. This popup is shown when you press *SELECT* on the recognizer name field.

The screenshot shows the TRACE software interface. At the top, it displays 'TRACE' and the date/time 'Jan 1 1990 12:54a'. Below this is a configuration window for 'Analyzer 1'. The window has several sections: 'Store' (set to 'L1+SW1+SW2'), 'Sequence' (with options 'If Edge' and 'Or if Wait forever'), 'Data stored' (set to 'Timing+State'), 'Trigger pos' (set to 'User-defined'), 'Run mode' (set to 'Auto-repeat'), and 'Run parameters'. Below the configuration window is a 'Words and Filters' table. A 'SET TRIGGER WORD' popup menu is overlaid on the table, showing options for 'x', '0', and '1'.

Label:	a	b	c	d	e	f	g	h	i	j	k	l	m	n
SET TRIGGER WORD	+	+	+	+	+	+	+	+	+	+	+	+	+	+
x : All Don't Care	x	x	x	x	x	x	x	x	x	x	x	x	x	x
0 : All zeros	0	0	0	0	0	0	0	0	0	0	0	0	0	0
1 : All ones	1	1												

Overlapping Labels

A channel may be present in different labels. You may change the value for such a channel in a pattern field of one of the labels. When you change the value, the pattern fields of the other labels which also contain this channel are automatically updated. As an example consider the Trace menu shown below. If you change for example the value for "o1", the pattern field for "output" is updated accordingly.

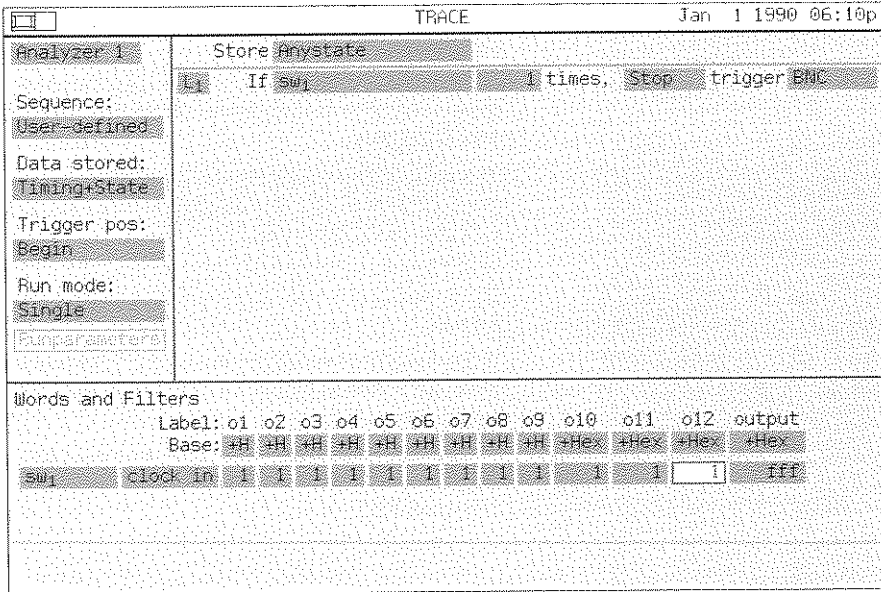

Ranges

For the range detector, two rows are available. The upper row (RangeH) allows you to specify the upper parts of the ranges for the labels. The lower row (RangeL) allows you to specify the lower parts of the ranges for the labels. See also "Range Detector" beginning on page 5-12.

Sequencer Facilities

The sequencer built into the PM 3580/PM 3585 Logic Analyzers has the following properties:

- Eight levels.
- Go to conditions can be state or timing.
- State and timing conditions may be mixed within any sequence.
- Occurrence counters for go to conditions.
- State and timing sections of an analyzer may be separately triggered.
- At any level, the sequencer can be instructed to wait for a pulse from the sequencer of the other analyzer (PM 3585 only).
- At any level the sequencer can be instructed to generate a pulse for the sequencer of the other analyzer (PM 3585 only).
- At any level the sequencer can be instructed to wait for an external pulse from the TRIG IN BNC connector.
- At any level the sequencer can be instructed to generate an external pulse for the TRIG OUT BNC connector.
- At any level the sequencer can be instructed to store specific state samples only (selective storage of state data).

Level Structure

The sequencer can have a maximum of eight levels. Each of these levels can independently have its own structure, ranging from simple to complex.

The simplest level construct is:

① If ② times, goto ③

While the most complex is:

①
 ② Store ③
 After ④
 If ⑤ times, goto ⑥ trigger ⑦
 Or if ⑧ times, goto ⑨ trigger ⑩

In the level construct, five different columns are distinguished as indicated above. These are:

1 Level number:

Shows which level is concerned, acts as a label to branch to, and allows you to select level options.

2 Condition:

Store: Specifies what state data should be stored. The storage condition may be any combination of state pattern recognizers.

After: Specifies whether the sequencer must be suspended until either the other analyzer (on PM 3585) or BNC has provided a signal.

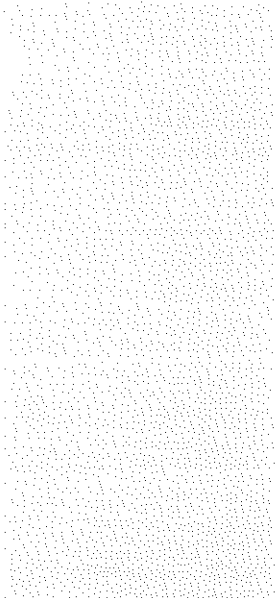

If/Or If: Specifies the pattern or patterns that must occur to go to the specified level in the sequence. The *If* condition has higher priority than the *Or If* condition. *If* and *Or If* conditions may be any combination of state recognizers, timing pattern recognizers or a time-out value.

- 3 Times: Specifies the number of times that the condition should occur before the branch takes place.
- 4 Go to: Specifies the level to go to after the condition was found the specified number of times.
- 5 Trigger: Specifies which units (one or more of Timing, State, BNC, other analyzer, or none) must be triggered when the *If* or *Or If* condition was found the specified number of times.

Note that when "Stop" is selected in the *Goto* field, the timing and state sections are implicitly triggered.

Creating a Level

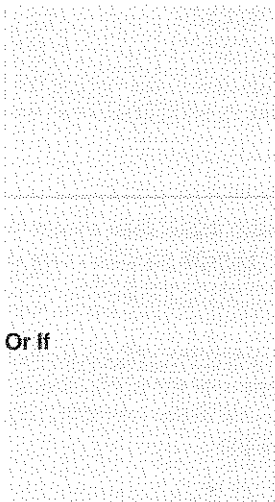

You insert a new level by pressing the *INSERT* key while on the *level* field. Pressing the *DELETE* key while on the *level* field deletes that level. If only one level is left, you may not remove it. At least one level must remain in the Sequencer area.

On inserting a new level it is displayed either in its simplest form, or in its simplest form together with a "Store" line (see "Store" on page 5-25).

You can create a more complex level structure by selectively adding different lines to the structure of that level.

Or If

The *Or If* line is simply added by pressing the *INSERT* key while on one of the fields 2 - 5 of the *If* line. The *Or If* line is deleted from the level structure by pressing the *DELETE* key while on one of the fields 2 - 5 of the *Or If* line.

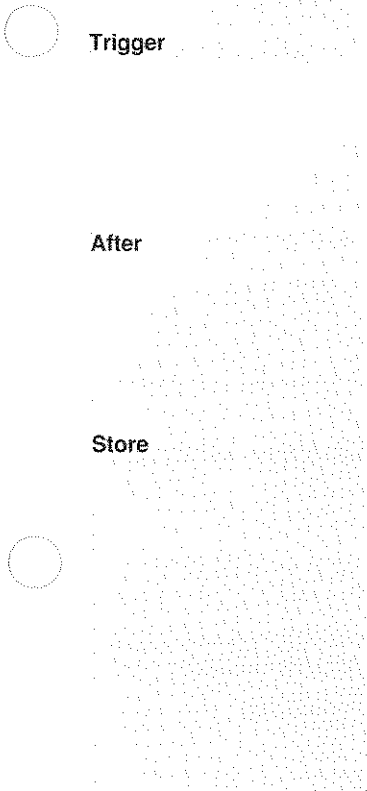

Note that the *Or If* line cannot be inserted per level if the sequence is of the type *Restart* (refer to "Restart Sequence" below for more information).

The **trigger** field is simply attached to the *If* or *Or If* lines by selecting the trigger option on the Level options popup menu for the level. This popup is accessed by pressing **SELECT** while on the *level* field.

Deselecting the trigger option for this level on the popup menu removes the **trigger** field from the level construct.

After

The **After** line is simply added to the level structure by selecting the After option on the level options popup menu for the level. This popup is accessed by pressing **SELECT** while on the *level* field.

Deselecting the After option for this level on the popup menu removes the **After** line from the level construct.

Store

The **Store** line cannot be added separately per level. Instead, this line is automatically present in the structure of a level if you set the global store condition to "Per Level". This global store condition is displayed on a separate line above the sequence when you instruct the analyzer to store state data by setting the *Data Stored* field in the Trace menu to either "State only" or "Timing + State".

Note: If you do selective data acquisition, the trigger word which causes the triggering of the state section (either via *stop* or *trigger state*) is only stored in memory if this trigger word is also specified in the store condition.

Time-Out Value

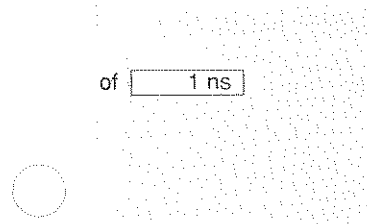

The Time-out option in the *If* and *Or If* fields allows a branch to be performed after a certain amount of delay.

When you select time-out, the times expression changes to the field shown at left. The time-out value field is real numeric, 40 ns through the maximum time-out value, in steps of 20 ns with a default of 40 ns. If the occurrence of the Time-out condition leads to a sequencer stop (*i.e.*, *Goto*

field is "Stop"), then the maximum time-out value is 65,535 ms. Otherwise the maximum value is 1.3 ms.

Restart Sequence

The restart sequence allows you to restart the sequencer from level 1 if the restart condition is met. If you select sequence type "Restart" in the Run Definition area, the restart condition is displayed on a separate line above the sequence. It is actually a shorthand notation of:

Or if [] times, goto L₁
at each level.

Examples

Below are a number of examples showing possible usage of the sequencer.

Program Flow

A procedure "Test" is called from different places in a program. Only if it is entered via the calling sequence:

Procedure A, then Procedure B
does something go wrong.

The program sequence Procedure A, Procedure B, Procedure Test should be traced in order to detect the problem.

The program flow can be symbolically depicted as:

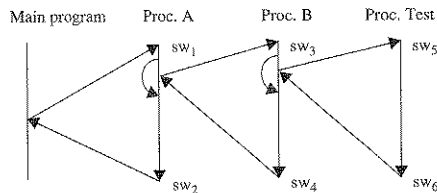

State words sw_1 through sw_6 are used to detect the entry and exit of the different procedures, as indicated in the figure of the program flow above.

Note that calling Procedure B from within procedure A is conditional, so may be skipped, as indicated by the curved arrow. The same applies to the calling of procedure Test from within procedure B.

Using these state words, the sequence to detect this program flow and trigger on it is:

```

L1   If  $sw_1$    1 times, goto L2
L2   If  $sw_3$    1 times, goto L3
      Or if  $sw_2$   1 times, goto L1
L3   If  $sw_5$    1 times, Stop
      Or if  $sw_4$   1 times, goto L2

```

In level 1, the sequencer waits until procedure A (sw_1) has been called, and then goes to level 2.

In level 2, the sequencer waits until either procedure B has been called (sw_3) or procedure A is ended (sw_2). If procedure A has been left, the sequencer returns to level 1, again waiting until procedure A is called. If procedure B has been called, the sequencer progresses to level 3.

At the third level the sequencer waits until either procedure Test has been called (sw_5) or procedure B has been ended (sw_4). If procedure B has been left, the sequencer returns to level 2.

If procedure Test has been called, the sequencer stops and triggers the acquisition hardware. Using the trigger position facilities (*Trig Pos* field in the Run Definition area), you can opt to store a specific amount of samples after the trigger before acquisition is completely stopped. (See "Trigger Point Position" beginning on page 5-5.)

Interrupt Response Time

As another example we will use the analyzer to check if an interrupt is serviced in time. The figure below shows the problem. If the interrupt is not serviced within the time interval indicated by "Maximum response time", the analyzer should trigger.

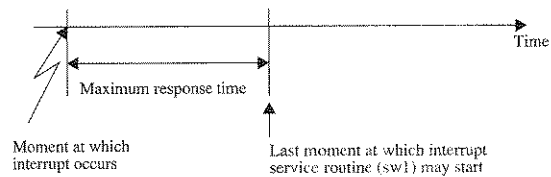

The following sequence can be used to detect a response failure in the target system:

```

L1  If  Edge  1 times, goto L2
L2  If  Time-out of 100 ms, Stop
    Or if  sw1  1 times, goto L1
  
```

After detection of the interrupt, using the Edge detector of the analyzer, the sequencer proceeds to level2, where a time-out is started. If the service routine, (sw₁) is started before the time-out period is expired, the sequencer returns to level 1 to wait for a new interrupt to occur. Otherwise the sequencer stops and triggers the acquisition hardware.

In this example note, particularly, that state and timing patterns are used in a single sequence.

Check Minimum Pulse Width

In this example the analyzer is used to check if the pulse width of a signal is always large enough.

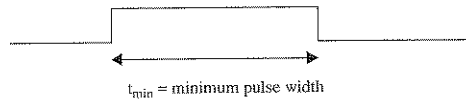

The sequence is:

L₁ If tw₇ ≤ t₇ 1 times, Stop

Where t₇ is defined such that t₇ = t_{min}. If the pulse width is less than, or equal to t_{min}, the analyzer will trigger.

Check Maximum Pulse Width

This example checks if the pulse width of a signal is not too long.

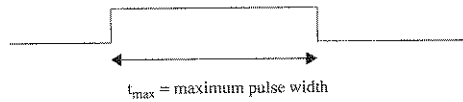

The sequence is:

L₁ If tw₇ > t₇ 1 times, Stop

Where t₇ is defined such that t₇ = t_{max}. The analyzer now triggers if the pulse width is greater than t_{max}.

Check Pulse Duration

In this example we will use the analyzer to detect whether the duration of a pulse lies between t_{min} and t_{max} , i.e.,

$$t_{min} \leq \text{pulse duration} \leq t_{max}$$

or graphically:

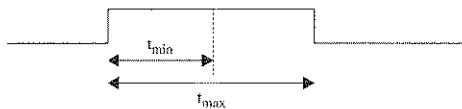

In order to do this, we have to use the two filter times t_7 and t_8 such that $t_7 = t_{min}$, and $t_8 = t_{max} - t_{min}$, as indicated in the figure below:

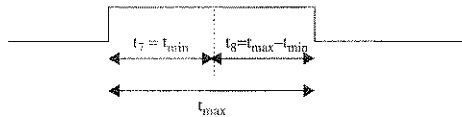

The sequence should now be programmed such that it first detects whether the pulse is wide enough, i.e., $> t_7$. Then it should detect whether it is not too long, i.e., $\leq t_8$. The following sequence will, indeed, cause the analyzer to trigger only if the pulse duration lies in-between the two boundaries specified.

- L_1 If $tw_7 > t_7$ 1 times, goto L_2
- L_2 If $tw_8 \leq t_8$ 1 times, Stop
- Or if $tw_8 > t_8$ 1 times, goto L_1

Note that, for this example, both tw_7 and tw_8 are required, and that both should be programmed to match on the same pattern (i.e., $tw_7 = tw_8$). This is because a word can only be programmed to have one filter time simultaneously.

Check Pattern Sequence

The sequence below can be used to check if three patterns always occurs in the proper order. If the sequence is interrupted (sequence break) the analyzer triggers. Words sw_1 , sw_2 and sw_3 are programmed to respectively match the first, second and third pattern of the pattern sequence to be verified.

The sequence is:

L_1 If sw_1 1 times, goto L_2

L_2 If sw_2 1 times, goto L_3

Or if sw_2 1 times, Stop

L_3 If sw_3 1 times, goto L_1

Or if sw_3 1 times, Stop

After the first pattern has been detected, it is checked whether the next two samples match the second and third patterns. If this is not the case, the sequencer stops and acquisition hardware is triggered. Otherwise the sequencer goes to level 1 and starts the search for the first pattern again.

Wait for a Pattern Sequence

In this example, a sequence is defined such that the analyzer will wait until three patterns occur in a specific order. The pattern sequence is always preceded by a pattern not occurring in the sequence. Words sw_1 , sw_2 and sw_3 are programmed to respectively match the first, second and third pattern of the pattern sequence to be verified.

The sequence is:

L_1 If sw_1 1 times, goto L_2

L_2 If sw_2 1 times, goto L_3
 Or if sw_2 1 times, goto L_1

L_3 If sw_3 1 times, Stop
 Or if sw_3 1 times, goto L_1

One Immediate Sequence of Two Patterns

In this example, the analyzer should trigger if a pattern, "p₂", immediately follows another pattern, "p₁". Patterns p₁ and p₂ are valid for the same state clock. Furthermore, pattern p₁ may occur in a variable number of consecutive samples immediately preceding pattern p₂.

Words sw₁ and sw₂ are programmed to match p₁ and p₂ respectively.

Two alternative solutions can be used for this sequence.

The sequence for the first alternative uses an immediate state word pair (sw₁₂ in this case) and is:

L_1 If sw_{12} 1 times, Stop

The sequence for the second alternative is shown below:

L_1 If sw_1 1 times, goto L_2

L_2 If sw_2 1 times, Stop
 Or if $sw_1 * sw_2$ 1 times, goto L_1

The use of an immediate state word pair in this case is thus not absolutely necessary, but does allow a simpler sequence set up.

Two Immediate Sequences of Two Patterns

In this example we will use the analyzer to detect the occurrence of an immediate sequence of patterns p_1 and p_2 , or an immediate sequence of patterns p_3 and p_4 in a long sequence of patterns sampled. All patterns are valid for the same state clock.

Proper detection requires the analyzer to keep track of the patterns according to the following state diagram:

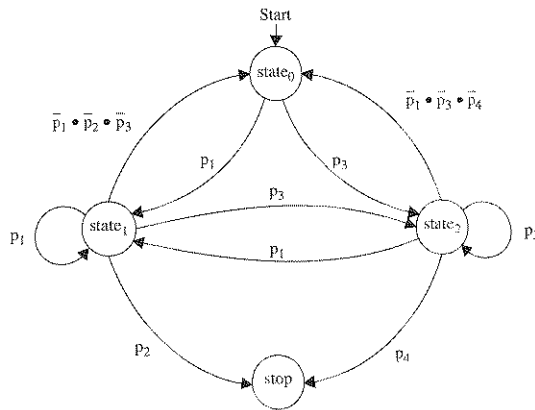

Words $sw_1 - sw_4$ are programmed to respectively match $p_1 - p_4$. Use of immediate state word pairs sw_{12} and sw_{34} as in the sequence below, allows the analyzer to trigger as required.

The sequence is:

L_1 If $sw_{12} + sw_{34}$ 1 times, Stop

Separately Trigger State and Timing

Within a program, a specific sequence of two procedures starts a hardware action on the bus system. As soon as the hardware action is started, an error occurs in the system.

A sequence is required such that the part of the program creating the hardware action can be traced, as well as the resulting hardware actions.

The following state words are defined:

- sw₁: beginning of the first procedure of the program sequence.
- sw₂: beginning of the second procedure of the program sequence.
- sw₃: ending of the first procedure of the program sequence.

TimeWord: hardware action started by the program.

In the sequence below, these state words are used to track the specific sequence of the two procedures and trigger the state and timing sections of the analyzer in accordance with the requirements stated above.

- L₁ If sw₁ 1 times, goto L₂
- L₂ If sw₂ 1 times, goto L₃ trigger State
- Or if sw₃ 1 times, goto L₁
- L₃ If TimeWord 1 times, Stop

Note that if the sequencer stops, it implicitly causes the timing and state sections to stop data acquisition. In this particular example, the state section was already triggered to stop acquisition on the transition from level L₂ to L₃.

Predefined Sequences

Predefined sequences in many cases will provide you with just the options you require. They can also be used as a basis for your own definitions.

This is the predefined sequences Trace menu:

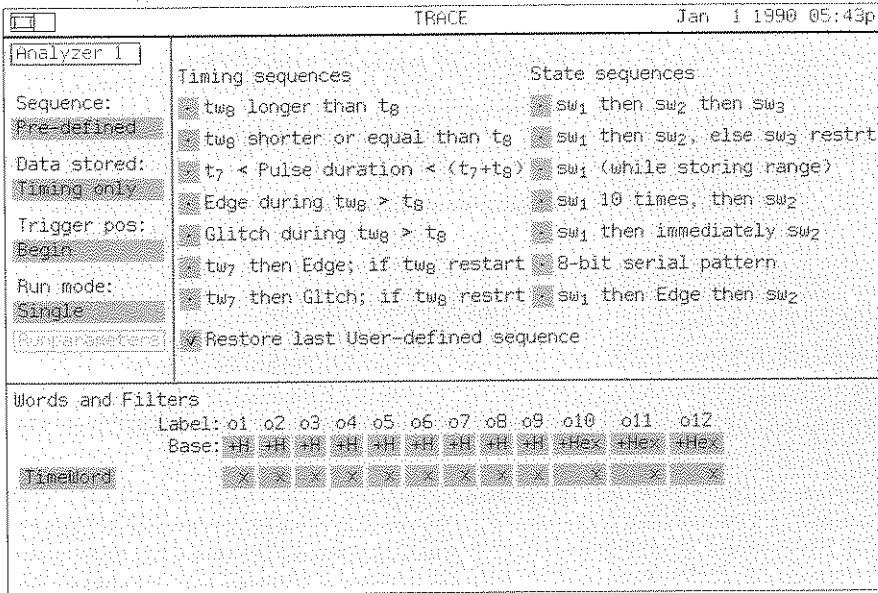

The default sequence is "Restore last User-defined sequence", and the default user-defined sequence is:

L₁ If **TimeWord** **1** times, **Stop** trigger **BNC**

This means that the analyzer will sample and store data until the trigger condition (TimeWord) is met.

And in the Trigger words area is shown:

TimeWord **X** **X** **X** **X** ...

which means that any bit pattern matches. Thus the trigger is found immediately we begin sampling.

On the left hand side of the predefined trigger sequences menu are the timing sequences, and on the right hand side, the state sequences. The state sequences are only selectable if a state clock has been defined.

The Predefined Timing Sequences

The timing sequences are (note that most of these sequences are described further in "Timing Pattern Recognizers" beginning on page 5-7):

tw_8 longer than t_8

Triggers if the duration of a pattern (tw_8) is greater than t_8 .

tw_8 shorter or equal than t_8

Triggers if the duration of a pattern (tw_8) is less than or equal to t_8 .

$t_7 < \text{Pulse duration} < (t_7 + t_8)$.

Triggers on a pulse (pattern) for which

$$t_{\min} \leq \text{pulse duration} \leq t_{\max}$$

$$t_7 = t_{\min}; t_8 = t_{\max} - t_{\min}$$

Compare example "Check Pulse Duration" beginning on page 5-30.

Edge during $tw_8 > t_8$

Triggers on an edge which occurs during the presence of a pattern which has been present for at least a specified time (Compare "Edge Detector" on page 5-9).

Glitch during $tw_8 > t_8$

Triggers on a glitch which occurs during the presence of a pattern which has been present for at least a specified time (Compare "Glitch Detector" on page 5-8).

tw_7 then Glitch; if tw_8 restart

Triggers on a glitch occurring after a specific pattern (tw_7). However, should a second condition occur before the glitch is found, then restart the cycle.

The Predefined State Sequences

The State sequences are as follows. Except for the third sequence (store range) all state data is stored:

sw₁ then sw₂ then sw₃

Triggers on a sequence of three state words, one occurring after the other.

sw₁ then sw₂, else sw₃ restart

Triggers on the sequence of two state words (sw₁ and sw₂), provided that sw₃ does not occur before sw₂.

sw₁ (while storing Range)

Triggers on one state word and limits the data stored.

sw₁ 10 times then sw₂

Triggers on one state word after another state word has been detected 10 times.

sw₁ then immediately sw₂

Triggers if state words sw₁ and sw₂ are recognized in two consecutive samples, with sw₁ being the first recognized. Compare examples "One Immediate Sequence of Two Patterns" on page 5-32 and "Two Immediate Sequences of Two Patterns" on page 5-33.

8-bit serial pattern

Triggers when 8 state words follow each other in a specified order without a break. Compare the example "Check Pattern Sequence" beginning on page 5-31.

sw₁ then Edge then sw₂

Triggers on one state word followed by a change of state of one or more signals followed by another state word.

Explanations of the exact meaning of the terms in these sequences are to be found in the sections concerning pattern recognition beginning on page 5-7. They are also defined in the "Timing Sequences" and the "State Sequences" in the *PM 3580/PM 3585 Reference Guide*.

Last User-defined Sequence

The last User-defined sequence option allows you to use the last sequence you set up as a User-defined or Restart sequence instead of one of the predefined sequences.

You may also select one of the predefined sequences, then change it as required. To do so, you have to go to the *sequence* field in the Run definition area and select the option "User-defined" in this field. The currently selected Predefined sequence is then used as a template for the User-defined sequence. If you previously had a user-defined sequence, this is then replaced by the selected predefined sequence.

On returning from User-defined to predefined sequences, the "Last User-defined sequence" is the default.

One user-defined sequence is always remembered, so you can use a predefined sequence, then come back and use your last user-defined sequence.

Repetitive Measurements

You can set up your analyzer to automatically restart itself after each non-manual acquisition stop. This is called the auto-repeat mode and can be selected in the Run Definition area of the Trace menu, in the *Run Mode* field.

Starting Repetitive Measurements

When auto-repeat mode has been selected, pressing the *RUN* key starts the analyzer. After the trigger condition has been detected and acquisition has stopped, the analyzer displays the data and then automatically restarts itself.

You can specify the amount of time between analyzer stop and automatic restart using the run parameters popup menu.

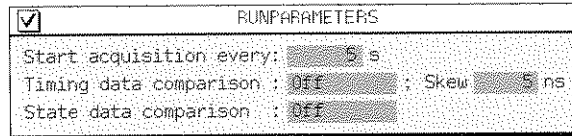
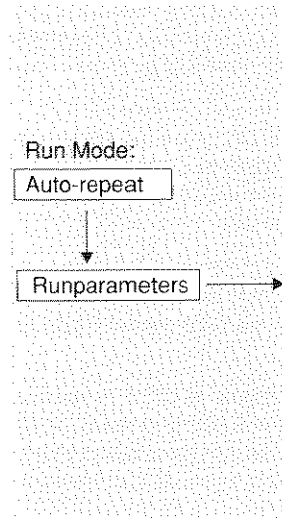

The value specified in the *Start acquisition every* field determines the amount of time between analyzer stop and automatic restart (5 sec. by default).

Terminating Repetitive Measurements

The automatic repeat can be terminated on the basis of data comparison results between newly acquired data and data stored in reference memory.

Data can be stored in reference memory by using the copy functions provided in the special functions popup menu of the display menu (see Chapter 3, "Menu Overview": "The Special Functions Popup Menu", and the "Display Special

Functions Menu" in the *PM 3580/PM 3585 Reference Guide*). Reference data can also be stored in memory by loading a measurement file from disk already containing reference data.

Stop Condition

You can select whether auto-repeat should stop if the newly acquired data is equal to the reference data or if it is unequal to it. This is done in the *Timing data comparison* and *State data comparison* fields in the run parameters popup menu.

The value for both these fields can be toggled between off, equal, and unequal independently. The value selected for a specific data type (state, timing) is only relevant if that type of data is also stored during a run. (That is if that type of data is indicated in the *Data stored* field of the Trace menu.)

Manual Stop

If the *Data comparison* field is set to *off* for the type or types of data stored, the analyzer will restart itself every time. It can then only be stopped manually using the *STOP* key or by switching to another menu.

Changing Menus

After the first run, the display is automatically shown. As long as you stay in this menu, and the stop condition for auto-repeat has not been met, the auto-repeat mode remains active.

If you perform cursor manipulations, or other actions on the display menu, the counter stops counting down, and is reset to the value specified in the run parameters menu. The counter can only reach zero if you do no manipulations during countdown.

Note that pressing the *STOP* key will always stop auto-repeat.

Data Comparison

Data comparison is performed between R and S cursor positions as last specified while viewing New, Reference or Compare data on the Display menu. R and S cursor positions can be set independently for Analyzer 1 State, Analyzer 1 Timing, PM 3585 Analyzer 2 State, and PM 3585 Analyzer 2 Timing.

Note: If the Display menu is in split-screen mode and both are showing the same type of data from the

same Analyzer, then the R and S cursor positions from the last-selected window (i.e., containing the highlighted field) are taken.

Repeat Mode Timer

If the auto-repeat mode is selected (*Run mode* field is set to auto-repeat), a time counter is displayed on the menu bar immediately adjacent to the analyzer activity icons. If the auto-repeat mode is inactive, such as when the *RUN* key has not yet been pressed, or the auto-repeat is stopped, this time counter is displayed in *light gray*.

If the auto-repeat mode is active, the counter is displayed in *black and is counting down*. On reaching zero, an acquisition run is automatically started.

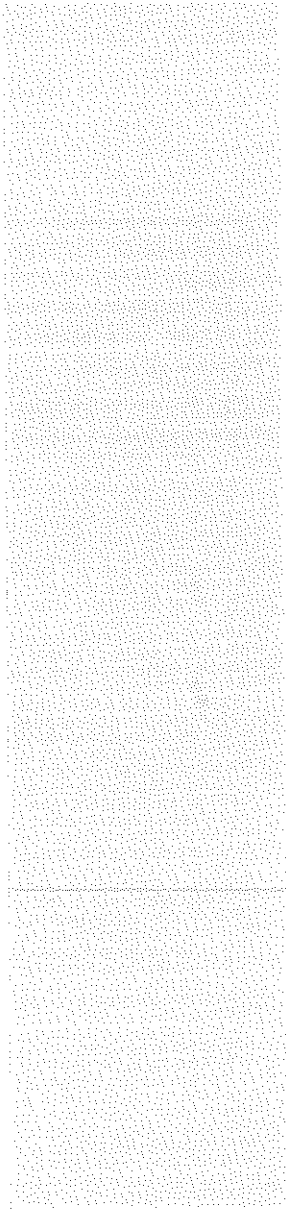

Chapter 6

Analyzing the Data

- Display Concepts 6-2
 - Data Source 6-4
 - Data Type and Form 6-6
 - Reference Data 6-7
 - Data Comparison 6-7
 - Measurement Data Overview 6-8
 - Time Origin - T_0 6-9
 - Time or Sample Numbers 6-10
 - Sample Number 0 6-10
 - Dial Operation 6-11
 - Viewing Parts of the Measurement Data 6-12
 - Display Locators 6-14
 - Measurements (R and S cursors) 6-15
 - Selecting Labels for Display 6-16
 - Display of Sequencer Levels 6-17
- Waveform Displays 6-18
 - Dial Movement (Dial Mode) 6-19
 - X-scale (T/div and S/div) 6-21
 - Y-scale 6-23
 - Bus Data 6-23
 - Waveform Data Representation 6-26
 - Label Values 6-26
 - Accumulate Mode 6-27
- List Displays 6-28
 - Dial Movement (Dial Mode) 6-29
 - List Data Representation 6-30
 - The Find Function 6-30
 - "Time" Label 6-31
 - "Level" Label 6-32
 - Label Base 6-32
 - Disassembly 6-33
- Split Screen 6-34
 - Creating a Split Screen 6-34
 - Deleting a Window 6-35
 - Active Window 6-35
 - Moving Between Windows 6-35
 - Coscroll 6-36

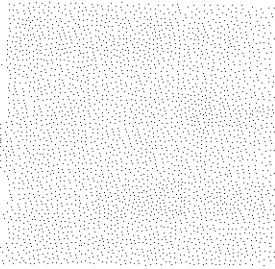

This chapter describes how the Display menu is used. An example of the timing waveform display and the state list display are shown on the opposite page.

Display areas, functions and operations are similar for all four types of display (timing waveform and list, state list and waveform). Therefore the concepts common to all types of display are described first. Then the items specific to the different display formats (waveform and list) are described separately.

Display Concepts

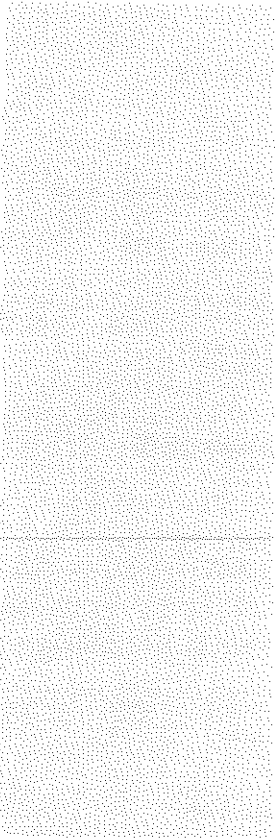

The two rows at the top of the Display menu contain a number of selectable fields. These two rows together form the display definition area. This gives you information about the current display, allows you to selectively move through the display, and lets you change aspects of the display.

The labels shown are the labels you defined on the Format menu. You can scroll, delete, replace, add (more than once if required), and reposition labels.

The polarity and base below the labels in a list display show, respectively, the polarity set on the Format menu, and the base of the data displayed for that label. You can change the base for a label at any time.

The columns on the right-hand side of the waveform display show the polarity set on the Format menu and the values of the labels. The value is shown for the position defined by the *Displayed Value* field ("Value at ..") above this column, in the display definition area.

The data display shows the data captured for the labels. The center of the data display is marked by a special cursor, called X for the waveform display, and Y for the list display. In addition two more cursors R and S are available on the display.

The display locator shows which part of the total measurement (timing or state as appropriate) is currently visible on the screen. The gray bar on which the display locator is positioned represents the total timing or state measurement.

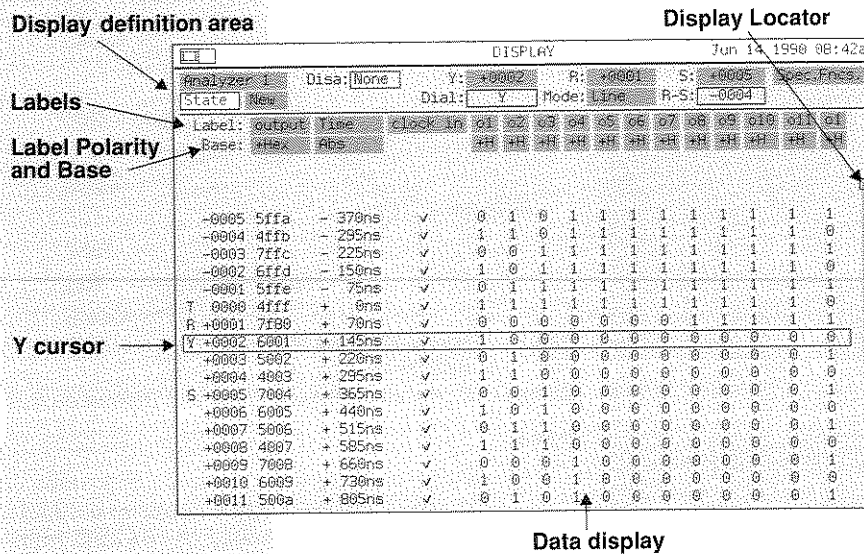
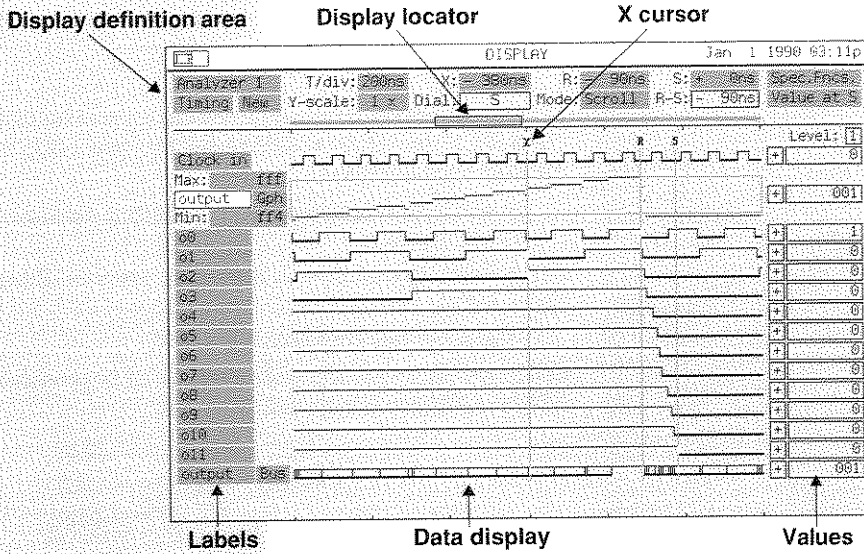

Data Source

Different sources of data may be present in your PM 3580/PM 3585 Logic Analyzer simultaneously, depending on the following parameters:

- which analyzers have pods connected (Configuration menu).
- which type of data is stored per analyzer (Trace menu).
- whether reference data is present.

Schematically the sources of data which may be present in your analyzer can be depicted as follows:

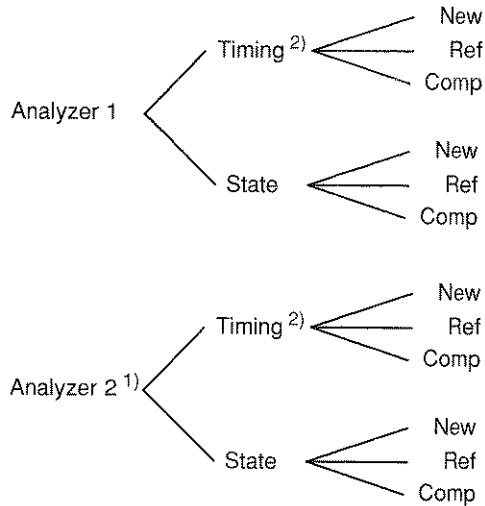

New = Newly acquired data
Ref = Reference data
Comp = Comparison between New and Reference data

Notes:

1. Display of Analyzer 2 information is possible on PM 3580 instruments only if measurement data is loaded from files generated on PM 3585 instruments.

2. Timing data also includes glitch data if glitches have been stored (Data stored field in Trace menu is set to "Timing+Glitch").

You can select to display the data from any one of these sources using the three fields at the left-hand side of the display definition area.

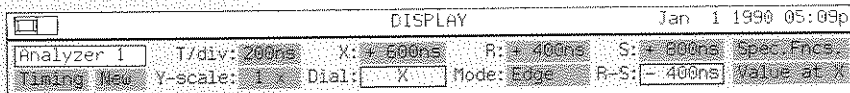

Three fields to select the data source

- **Analyzer Name** This field selects between data from Analyzer 1 or Analyzer 2. On PM 3580 instruments data for Analyzer 2 can only be selected if a measurement file has been loaded which was generated on a PM 3585 instrument.
- **Data Type and Form (Timing/State)** This field selects between the display of timing data or state data and also the form of the display: waveform or list. (See below).
- **Data Source** This field selects between the display of newly acquired data, (New), reference data (Ref) or the results of the comparison between New and Reference data (Comp).

The data shown on the menu the first time it is displayed, depends on whether data has already been acquired, and, if not, the setting of the *Data Stored* field on the Trace menu. Data is shown, for preference, from Analyzer 1, and state data is shown rather than timing.

Data Type and Form

Timing Waveform Display

Both timing and state data can be shown as waveforms or in list form. Both the type of data (State/Timing) and the form (List/Waveform) can be selected from the *Data Type and Form* field.

The *Waveform* display for *Timing* data shows traces for the data captured with the **internal** clock. If glitch data has been stored, glitches are also shown. (For more information see subsection "Waveform Data Representation on page 6-26.)

Timing List Display

The *List* display for *Timing* data shows these same transitions in a list form. That is, a list of the data captured with the **internal** clock. In this display, a new data line is present when a transition occurs in the data (one or more of all channels captured) with respect to the previous data line, not for every tick of the internal clock.

State List Display

The *List* display for *State* data shows a list of data captured with the specified **external** clock or clocks. Each line of the list represents a tick of (one of) the clock(s) and the data present on the signal lines at that time. (For more information see subsection "List Data Representation" on page 6-29). Alternatively, the State List display may show a disassembled list of the state data: see "Disassembly" beginning on page 6-32.

State Waveform Display

The *Waveform* display for *State* data shows traces for the data captured with the **external** clock. Note that the data values shown between clock ticks are the values captured at the previous clock tick. Therefore, data which *appears* constant on the display may have changed value once or several times between the external clock ticks.

Reference Data

Copying Data to the Reference memory

In addition to memory for storage of newly acquired data your analyzer contains a separate memory in which reference data can be stored. Newly acquired data can be compared with this reference data.

You can copy data to the reference memory by using the *Copy New to Reference* function field on the Display Special Functions popup menu. You can also use the *Exchange New and Reference* field.

Measurement File

If you saved a measurement to disk (using the Save command on the I/O menu) while reference data was defined, this reference data is also saved. If you load the measurement file (using the Load command on the I/O menu) the reference data will also be loaded.

Note: To make a Reference file for subsequent use you will save disk space and will be able to load faster if there is no New data. This will be the case if after acquiring a measurement you use "Exchange New and Reference" instead of "Copy New to Reference"

Data Comparison

Waveform Display

Comparisons can be made between new and reference data on the Display menu by selecting "Comp" in the *Data Source* field of the display definition area.

In the *Waveform display*, the data shown is the result of the comparison of New and Reference data using the exclusive-OR function. Differences between New and Reference data are displayed as high (1) and equalities as low (0).

List Display

In the *List display* New data is shown with the differences from the Reference data highlighted.

Repetitive Measurements

Data comparison can also be executed during *repetitive measurements*. The positions of the R and S cursors then determine which part of the measurement data is compared for autostop. (See Chapter 5, "Trace Control": "Repetitive Measurements").

Measurement Data Overview

An overview of all the data present in the analyzer memories, including reference data, is shown on the Display Special Functions popup menu. This menu is accessed by pressing *SELECT* on the *Display Special Functions* field ("Spec.Fncs.") at the right-hand side of the display definition area. For PM 3580 instruments, Analyzer 2 is only shown if a measurement file has been loaded which was generated on a PM 3585 instrument.

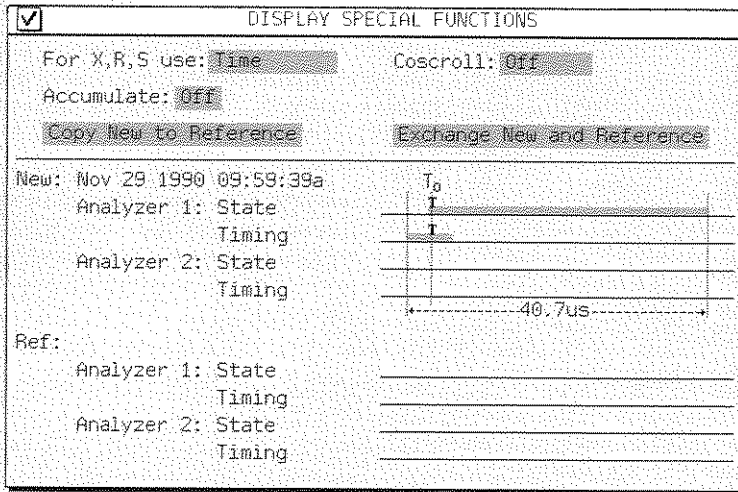

The indication of memory usage for newly-acquired data is detailed below. The indication of memory usage for reference data is equivalent.

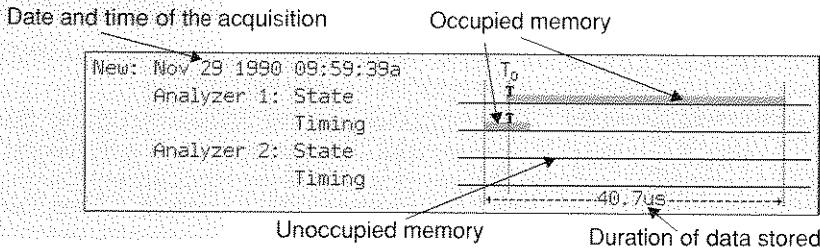

Time Origin - T_0

During an acquisition, two analyzers may be active (only one for PM 3580 instruments) and for each analyzer, two independent sections (timing and state). By default, all sections are triggered simultaneously at T_0 . However, each of the analyzers and each of its sections can be triggered at different instants. Consequently, four different (two for PM 3580 instruments) triggering instants may exist within a single measurement:

- Trigger for Analyzer 1, Timing.
- Trigger for Analyzer 1, State.
- Trigger for Analyzer 2, Timing (PM 3585 only).
- Trigger for Analyzer 2, State (PM 3585 only).

An example is shown in the figure below:

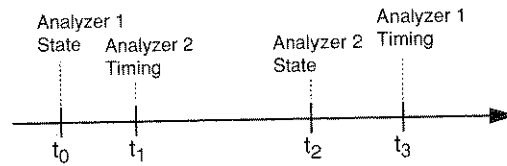

To properly correlate the data captured by the different sections one trigger instant is selected for references. This trigger instant is mapped to 0 and labelled T_0 .

This time instant is selected as follows:

- If there is only one trigger point in memory, then that point is taken as T_0 .
- If there is more than one trigger point in memory, then the trigger point with the earliest time is the time origin (in the example above this is the instant where the state section of Analyzer 1 was triggered).

If there is no trigger point in memory (the trigger has been lost) then the oldest sample in memory is taken to be T_0 .

Time or Sample Numbers

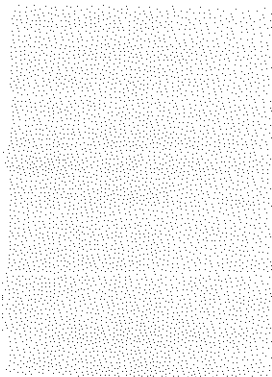

In case of samples occurring before T_0 these samples will have a negative time value associated with them.

Values in cursor position fields (X, Y, R and S) may show either time or sample numbers. To change between them, go to the Display Special Functions menu and press *SELECT* on the *For X,R,S use* and *For Y,R,S use* fields. (See "Measurement Data Overview" beginning on page 6-7.) For each type of display, time or sample number can be selected independently. The setting affects the X or Y, R, S, R-S fields, and, on the waveform displays, the division field (*T/div* or *S/div* respectively). See also "X-scale (*T/div* and *S/div*)" beginning on page 6-20.

Sample Number 0

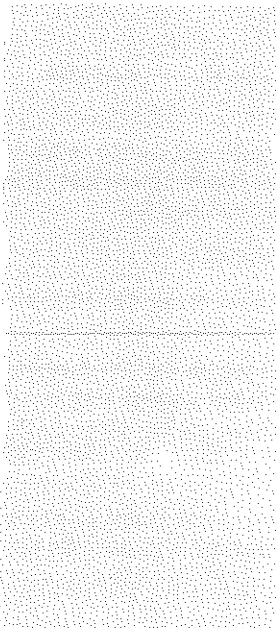

As was explained above there is only one time origin T_0 for the complete measurement and all timing values shown on the display are relative to this time origin. However, sample numbers are always relative with respect to the triggering instant of a section. The sample at the triggering instant is labelled 0. So in the example shown below each section has its own "sample number 0".

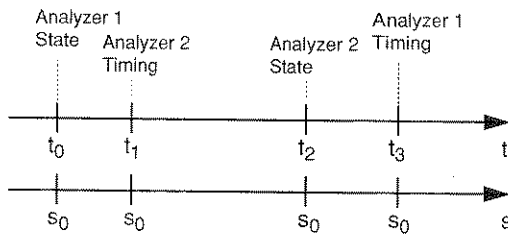

Note that if there is no trigger point in memory for a specific section, the trigger for that section occurred before the first sample which is stored in memory. This first sample will now be labelled "sample number 1".

Dial Operation

In the Display menu, the dial is used to scroll through the measurement data and to set reference cursors (R and S).

The dial can be operated in different modes. The dial mode, selected in the *Dial Mode* field, determines how much the element on which the dial currently operates (measurement data, R or S cursor) moves per click of the dial. For example each click may represent a movement of one or more pixels (step) or one line only or a whole page. For a complete overview see "Waveform Displays" beginning on page 6-18 and "List Displays" beginning on page 6-27.

For example:

Timing Waveform:

Cursor position fields

Analyzer 1	T/div: 200ns	X: 500ns	R: 400ns	S: 300ns	Spec. Fncs
Timing New	Y-scale: 1x	Dial: X	Mode: Edge	R-S: -400ns	Value at X

Dial and Dial Mode fields

State List:

Cursor position fields

analyzer 1	Disa: None	Y: +0002	R: +0001	S: +0005	Spec. Fncs
State New		Dial: Y	Mode: Line	R-S: -0004	

Dial and Dial Mode fields

Dial Locking

On cursor position fields (X,Y,R,S), auto dial locking takes place. That is, if the dial is moved when any of these fields is highlighted, the dial is locked to that field. When any other field is highlighted and the dial is turned, the dial affects the cursor that was last locked.

Viewing Parts of the Measurement Data

The center of the data display is marked by a special cursor, called X for the waveform display and Y for the list display. The position of this cursor in the total measurement is indicated in the X or Y *Cursor Position* field in the display definition area. The value in the *Cursor Position* field may be time or sample number (see "Time or Sample Numbers" on page 6-10). A time value in this field is relative to Time origin T_0 . A sample number is relative to the trigger point for the section (see "Sample Number 0" on page 6-10).

There are three ways to see other parts of the measurement data:

- By moving the data using the dial: Dial Movement.
- By typing in a new value for the center of the data display (X, Y): Absolute Movement.
- By positioning the center of the data display on a predefined point using a letter: Quick Movement

(Note that these methods are the same for all cursors – *i.e.* also R and S cursors).

Dial Movement

When the dial is turned while the *Dial* field indicates X or Y, the list or waveform is scrolled. The amount moved depends on what is set in the *Dial Mode* field and whether the highlight is on a label, or on a field in the display definition area. See "Waveform Displays" beginning on page 6-18 and "List Displays" beginning on page 6-27 for more detailed information.

Absolute Movement

First, using the arrow keys, move the highlight to the *X position* or *Y position* field (in the center of the display definition area at the top of the screen).

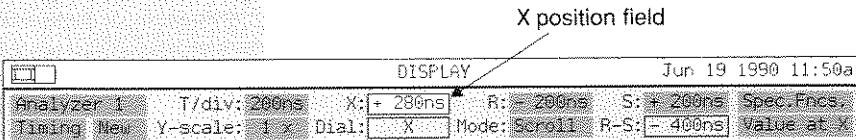

Start typing a number. A pop-up menu with your first digit appears. You can carry on typing the number: say 500. If you want to place the X or Y position *before* the trigger point, press the +/- key to change the sign.

Depending on whether you were editing a sample or a time value proceed as follows.

If you were editing a *sample number*, press *SELECT*. This closes the popup. The screen is refreshed so that the sample value selected for X or Y is in the center of the display area.

If you were editing a *time value* and you want to change the units also, proceed as follows.

Use the right arrow key to move to the units field, then, either press the appropriate key or press *SELECT* to toggle through the options.

Units

The units you may select for a cursor position are:

- n nanoseconds
- u microseconds
- m milliseconds
- s seconds
- k kiloseconds

Finally close the popup by pressing *HOME* then *SELECT*, or *HOME* again. The screen is refreshed so that the time position selected for X or Y is in the center of the display area.

Quick Movement

You can also move the X or Y position to a predefined position quickly by pressing an appropriate alphabetic key, as shown in the box below.

Quick Movement Characters

- | | | | |
|----------|-------------------|----------|------------------|
| B | Beginning of data | S | S position |
| C | Center of data | T | Trigger position |
| E | End of data | X | X position |
| R | R position | Y | Y position |

Pressing *SELECT* while on the *X* or *Y position* field pops up a list from which you can select one of these predefined positions. You can also select *Time* and *Sample* from this list. These, in turn, show a popup menu on which you can type in a number (see "Absolute Movement" above).

Display Locators

On the display, a display locator (a hollow rectangle) is shown. The display locator shows which part of the measurement data is currently visible on the screen. The gray bar on which the display locator is positioned represents the total measurement. The hollow rectangle represents the display. As you move through the measurement the position of the display locator is updated accordingly. The size of the display locator is calculated on basis of time or number of samples depending on whether time or sample numbers has been selected for the cursor positions.

Display locator

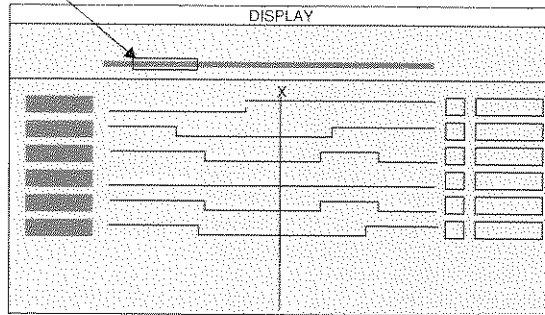

If *X* has a value that lies outside the data acquired, it is possible that no waveforms are shown. If this happens, the display locator shows you where you are. At least one edge of the hollow rectangle is always visible, no matter how far the cursor is placed outside the measurement.

As an example, the figure below shows a waveform display when the *X* position is far beyond the end of the data. For the list display, this applies with respect to the *Y* position.

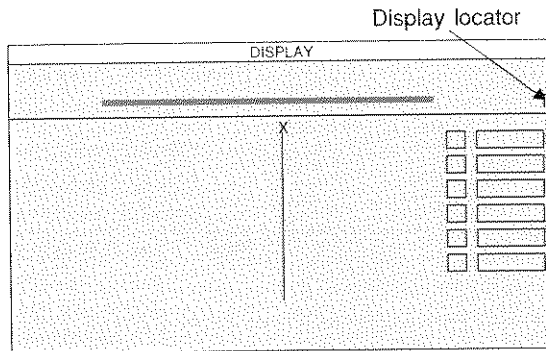
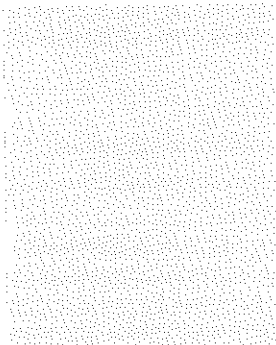

Measurements
(R and S cursors)

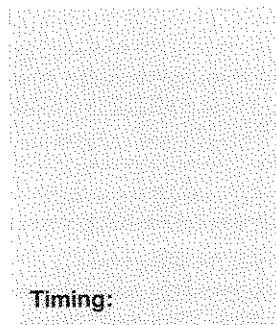

You can set the R and S cursors to measure differences between timing events (*e.g.*, the difference between edges on two different signals) or state events. The difference can be shown in time or sample numbers.

The position of these cursors is indicated in the display definition area. The value in these fields may be time or sample number (see "Time or Sample Numbers" on page 6-10). The difference between the R and S cursor positions can be read immediately from the R-S field.

Timing:

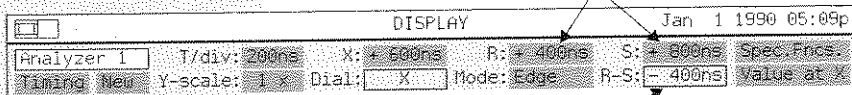

R and S position fields

R-S difference field

State:



R and S position fields

R-S difference field

The R and S cursors are also used to select the part of data that should be compared during repetitive measurements (see Chapter 5, "Trace Control": "Repetitive Measurements").

The position of the R and S cursors can be changed in three ways (compare "Viewing Parts of the Measurement Data" beginning on page 6-11):

- By using the dial: Dial movement.
- By typing in a new value: Absolute movement.
- By positioning the cursor to a predefined point using a letter: Quick movement.

Note: The R-S time difference field is only displayed to 3 or 4 significant digits. If greater accuracy is required, the maximum resolution R and S values can be read out from the R and S fields and manually subtracted.

Selecting Labels for Display

By default, all labels defined on the *Format* menu are shown in the *Display* menu and in the same order. Note that labels are only shown in the timing displays if the label attribute, Timing label, is set to "Data storage + triggering". Likewise, labels are shown in the state displays only if they are valid for at least one state clock. See also Chapter 4, "State Clocks": "Label Attributes" and "Clock Attributes".

Scrolling Labels

If more labels are present than can be shown on the display simultaneously you can scroll the labels. Go to the last label displayed using the arrow keys. Then press the appropriate arrow key (down in the waveform display, right in the list display). This will cause the labels to scroll one position. The first label disappears from the screen and a new label becomes visible in the last position.

You can scroll back the labels by going to the first label displayed and then pressing the appropriate arrow key.

Note: You should press the *HOME* key, cursor left or shift dial, on a waveform display to move from the label area to the display definition area if you have scrolled the labels.

Deleting Labels

To delete a label, highlight the label name (using the arrow keys) and press the *DELETE* key. Note that no data is lost, only removed from the display. You can always insert the label again later.

Adding Labels

You may find that removing labels not of interest at a particular time helps to simplify the display.

To add a label, highlight the label after which you want the new label to be inserted, and press the *INSERT* key. A menu of all the available labels (as you defined them in the Format menu) appears. Highlight the label you want, and press either *SELECT* or *INSERT*. The label is now added to the display.

Use delete then add to move a label to a different position.

Note: You may add the same label more than once.

Changing Labels

To replace one label by another, highlight the label you want to change, and press *SELECT*. A menu of all the available labels (as you defined them in the Format menu) appears. Highlight the label you want to appear in place of the current label, and press *SELECT*. The label is now replaced by the one selected.

Quick Label Selection

You can also change a label using the first character select method: highlight the label to be changed and press the first letter of the label to replace it. If there is more than one label starting with the same letter, keep pressing the letter until the required label is shown.

Hint: To insert a label before the first label, insert (add) the first label (so it appears twice), then change the first label to the one you want.

Display of Sequencer Levels

In all displays you can see at which level the sequencer was when a particular data sample was captured.

In waveform displays this is shown at the top of the values area in the *Level* field (information field).

In list displays a special label called "Level" is available. This label can be added as described in subsection "Selecting Labels for Display" on page 6-16.

Note: An "S" (Stop level) is shown as value for the level for those samples which were captured after the trigger.

Waveform Displays

On waveform displays, waveforms are shown for either timing or state data captured by the logic analyzer. An example of a timing waveform display is shown below. In the previous section, "Display Concepts" beginning on page 6-2, it has already been discussed how you can view other parts of the measurement data, measure differences using the R and S cursors, select labels, etc. This section discusses those items specific to waveform displays only:

- Dial movement (Dial mode).
- Setting the scale on the waveform display.
- Bus signals
- Graph display
- Values at a position
- Accumulate mode.

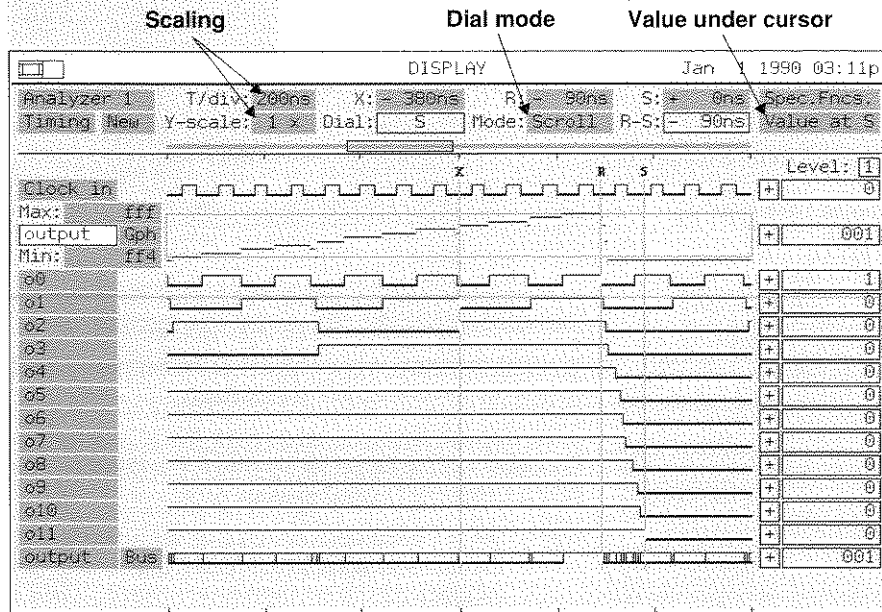

Dial Movement (Dial Mode)

If the Dial Field shows X, then turning the dial causes the waveforms to move. The amount moved depends on what is set in the Mode field and whether the highlight is on a label (at the left of the screen) or in the display definition area (at the top of the screen). The mode field also applies when moving the R and S cursors. For X, the cursor remains in the center of the display and the waveforms move in the direction the dial is turned. For R and S cursors, the cursors move in the direction the dial is turned.

The available mode settings are:

Step This mode is only for changing the X scaling (T/div or S/div). It is only available when the X scaling field is highlighted and does not appear on the mode popup. The Time or Sample number per division moves to the next or previous scale division per "click" (see "X-scale (T/div and S/div)" beginning on page 6-20).

Scroll The default for waveform displays. This mode allows very fine adjustment of the cursor. The waveforms or cursor move one or more pixels per "click".

Edge Moves the waveforms or cursor such that the appropriate cursor is on the next edge (transition). If a label field is highlighted, then the dial moves the cursor from edge to edge of that label only. If any other field is highlighted, the dial moves the cursor to the edge of any label which is displayed.

Division Moves the waveforms or cursor by one scale division (these are the marks below the display locator and at the bottom of the data display area). You can change the scale of these divisions: see "X-scale (T/div and S/div)" beginning on page 6-20.

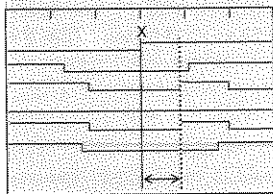
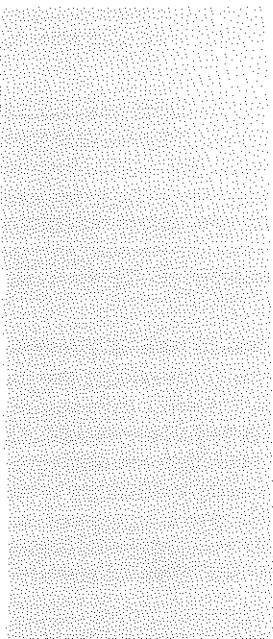

Distance moved in Edge Mode

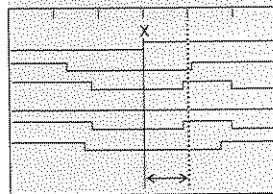

Distance moved in Div Mode

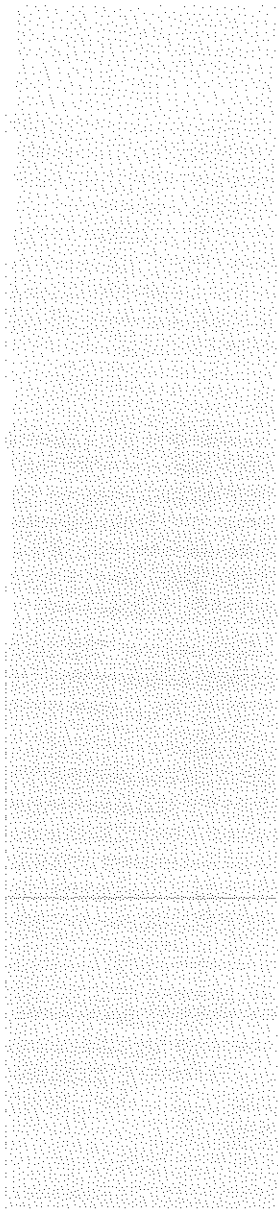

- Page** Moves one display page (the width of the data display) per "click".
- Level** Moves the waveforms or cursor such that the appropriate cursor is on the next (previous) sequence level transition. (Not available for Compare displays.)
- Glitch** Moves the waveforms or cursor such that the appropriate cursor is on the next (previous) glitch. If a label field is highlighted, then the dial moves the cursor from glitch to glitch on that label only. If any other field is highlighted, the dial moves the cursor to the next glitch on any label. (Not available for Compare displays.)
- Different** Only when Data Source field is *Compare*. Moves the waveforms or cursor such that the appropriate cursor is on the next (previous) difference between new and reference data. If a label field is highlighted, then the dial moves the cursor from difference to difference in that label only. If any other field is highlighted, the dial moves the cursor to the next difference in any label displayed. See "Data Comparison" on page 6-7.
- Equal** Only when Data Source field is *Compare*. Moves the waveforms or cursor such that the appropriate cursor is on the next (previous) equality of new and reference data. If a label field is highlighted, then the dial moves the cursor from equality to equality in that label only. If any other field is highlighted, the dial moves the cursor to the next equality in any label displayed. See "Data Comparison" on page 6-7.

X-scale (T/div and S/div)

Depending on the horizontal (X) scale set, a larger or smaller part of the total measurement is displayed. When first displaying newly acquired data, the Logic Analyzer sets the scale so that at least 10% of the total measurement is displayed.

The horizontal dimension (X) of the data display is divided into six divisions as shown on the line below the display locator and at the bottom of the display. You select the

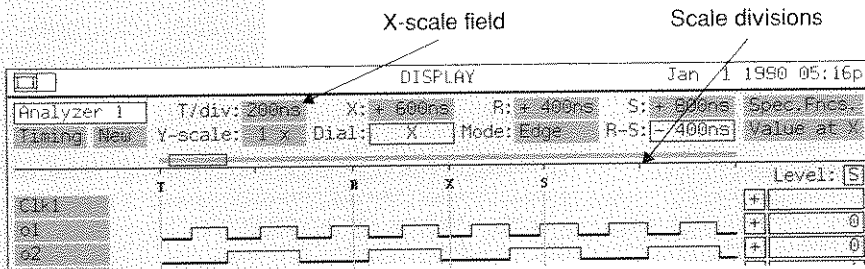

scale by specifying the number of units per division in the X-scale (T/div or S/div) field in the display definition area. Changing the X scale allows you to zoom in or out on the data around the X position.

The X-scale field shows T/div if the X, R and S fields show time values, or S/div, if they show sample numbers. You set the display to use time or sample numbers in the Special Functions menu (see "Time or Sample Numbers" on page 6-10) or you can use the pop-up menu which appear when you press SELECT on the X-scale field.

Note that "Sample" for timing data refers only to those samples in which a transition (high/low or low/high) has occurred on one or more analyzer channels which have been enabled for timing analysis in the FORMAT menu.

Using the Dial

There are two ways of changing the X scale:

- By using the dial.
- By typing in a new value.

With the *X-scale* field highlighted, you can change the scale with the dial. Turning clockwise you zoom in on the data and consequently the value in the *X-scale* field is *decreased*.

As the scale is changed, the display is updated to show the data at the scale requested. The time divisions that can be set are shown in the box below.

Time Scale Divisions:

5ns, 10ns, 20ns, 50ns, 100ns, 200ns, 400ns, 800ns, 2 μ s, 4 μ s, 10 μ s, 20 μ s, 50 μ s, 100 μ s, 200 μ s, 500 μ s, and so on with values 1, 2, 5, 10, 20, 50, 100, 200, 500 in ms, s and ks (kiloseconds) through 50ks.

Typing a Value

To change the X scale directly to a specified value, proceed as follows. Highlight the *X-scale* field. You can enter a number here or press *SELECT* to get a popup from which you can choose to set "Samples per division", "Time per division" or "Best". Enter the number that you want each of the 6 divisions across the top of the display to represent, then, for time, the units. Close the popup menu to get the instrument to accept the value.

If you select "Best" from the pop-up the analyzer sets the scale such that 10% of the total measurement is or can be displayed.

Note that changing from S/div to T/div and vice versa changes the display, and sets the current scaling appropriate to the selected value.

Y-scale

You may change the display height of a waveform. You do this by highlighting the *Y-scale* field in the display definition area. Then press a number 1 through 9 to select the vertical scaling required. Alternatively, you can press *SELECT* to get a list of scaling factors from which you can select the one required.

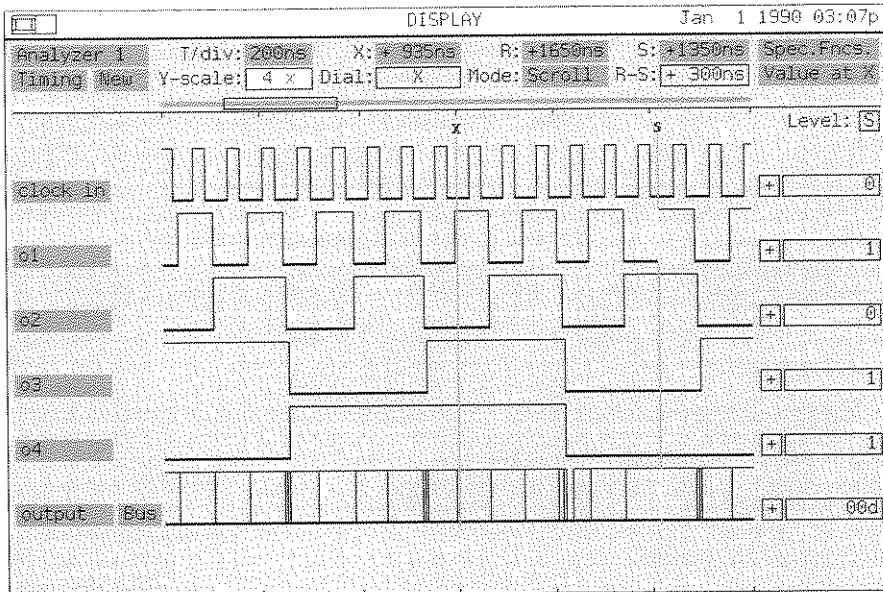

Bus Data

If more than one channel is connected to a label, by default, all signals of that label are shown together on the waveform display. The resulting waveform is the OR of each of the separate signals of the label. The figure above shows the effect. (Label "output").

The values field at the far right of the screen shows the hexadecimal value of the label at a specified cursor position (here it is "00d" under the X cursor). See "Label Values" on page 6-26 for more information.

Individual bus signals

Instead of showing the whole bus, you can show just one signal. To do this, highlight the bus field, and either press *SELECT* to toggle through the signals of the bus, or use the numeric keys to enter the number of the channel you want to display. The *B* key selects all channels (Bus). The

number of the channel selected, or "Bus" is shown in the field at the right of the label.

To show more than one signal from the bus, go to the bus label and press *INSERT* repeatedly.

Note: The channels of a bus label have index 0 through *n*, with 0 being the "right-most" channel assigned, and *n* the "left-most" assigned.

The bus may also be shown in graphic form. This expands the bus label to three lines as shown below.

Graphic display of bus data

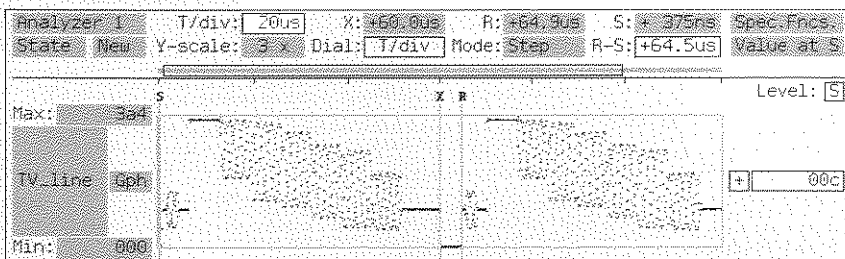

Note the difference in Y-scale

This example shows one of the ways that the graph mode can be used. The example shows two successive lines of an undecoded pay television system.

The top and bottom lines of the label ("Max:" and "Min:") indicate the hexadecimal value of the maximum and minimum value displayed. The first time the signal is displayed, these are set to the largest and smallest values of the signal found in the total measurement.

The "Max:" and "Min:" values can be adjusted individually. Press *SELECT* on either field to get a popup from which you can select the appropriate maximum or minimum.

You can set the maximum and minimum value to the maximum or minimum value of the signal found in the total measurement. Short-cut key M.

By pressing *R* or selecting R-S from the popup, this sets the minimum or maximum value to that which the bus takes over the samples between the R and S cursor positions.

Accumulate Mode

You can enable waveform "accumulate mode" in the *Display Special Functions* menu (see page 6-8). If you set "Accumulate: On" then the waveforms displayed on the screen are not refreshed each time a new data set is acquired. The new data then overlays all the previously acquired data since accumulate mode was enabled.

You can typically use this to examine the stability of a set of timing signals. An unstable baudrate on a serial communication link can cause parity errors. Incoming bits (RS232-Rx) are sometimes missed by the internal receiver clock. The instability rate can be traced over a period of time (R-S cursors). See example screen below.

Note that this is purely a bit-map function. The previously acquired data is not stored. So although you can at all times scroll the data on the screen, the data scrolling onto the screen will only be from the current acquisition, and will not be accumulated. If the picture is zoomed, the accumulated information is removed.

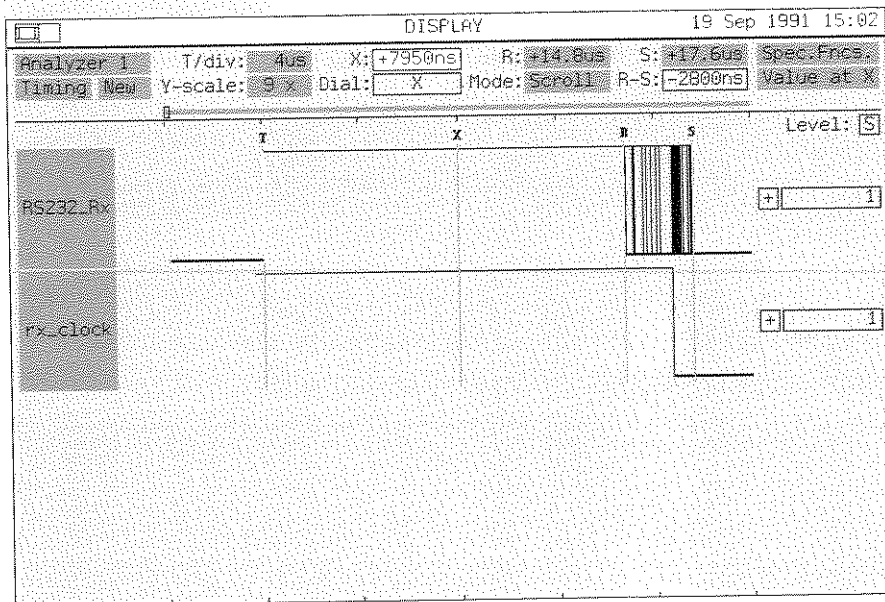

List Displays

On list displays, a list is shown of the data captured by the Logic Analyzer. An example of a state list display is shown below.

In the section "Display Concepts" beginning on page 6-2, we have already described how you view parts of the measurement data, perform measurements, select labels, etc. This section concerns only those items that are specific to list displays:

- Dial movement (Dial mode).
- The find function.
- "Time" label.
- "Level" label.
- Label base.
- Disassembly.

Labels in the screenshot:

- "Time" label
- Disassembler
- Dial mode
- Label Base
- Y cursor

Label	Time	Clock In	01	02	03	04	05	06	07	08	09	010	011	012
-0005	5ffa	- 370ns	✓	0	1	0	1	1	1	1	1	1	1	1
-0004	4ffb	- 295ns	✓	1	1	0	1	1	1	1	1	1	1	0
-0003	7ffc	- 225ns	✓	0	0	1	1	1	1	1	1	1	1	1
-0002	6ffd	- 150ns	✓	1	0	1	1	1	1	1	1	1	1	0
-0001	5ffe	- 75ns	✓	0	1	1	1	1	1	1	1	1	1	1
T 0000	4fff	+ 0ns	✓	1	1	1	1	1	1	1	1	1	1	1
R +0001	7f00	+ 70ns	✓	0	0	0	0	0	0	0	0	1	1	1
Y +0002	6001	+ 145ns	✓	1	0	0	0	0	0	0	0	0	0	0
+0003	5002	+ 220ns	✓	0	1	0	0	0	0	0	0	0	0	0
+0004	4003	+ 295ns	✓	1	1	0	0	0	0	0	0	0	0	0
S +0005	7004	+ 365ns	✓	0	0	1	0	0	0	0	0	0	0	1
+0006	6005	+ 440ns	✓	1	0	1	0	0	0	0	0	0	0	0
+0007	5006	+ 515ns	✓	0	1	1	0	0	0	0	0	0	0	1
+0008	4007	+ 585ns	✓	1	1	1	0	0	0	0	0	0	0	0
+0009	7008	+ 660ns	✓	0	0	0	1	0	0	0	0	0	0	1
+0010	6009	+ 730ns	✓	1	0	0	1	0	0	0	0	0	0	0
+0011	500a	+ 805ns	✓	0	1	0	1	0	0	0	0	0	0	1

Dial Movement (Dial Mode)

If the Dial Field shows Y, then turning the dial causes the list items to move. The amount moved depends on what is set in the Mode field and whether the highlight is on a label field (at the top of the list) or in the display definition area (at the top of the screen). The mode field also applies when moving the R and S cursors. For Y, the cursor remains in the center of the display and the *list items* move opposite to the direction the dial is turned. For R and S cursors, the *cursors* move in the direction the dial is turned. The available mode settings are:

- Line** Moves one line per "click". Clockwise is down, anti-clockwise is up.
- Page** Moves one display page (the length of the data display) per "click".
- Level** Moves the cursor to the next (previous) sequence level transition. Not when Data Source field is *Compare*.
- Find** Moves the cursor to the next (or previous) occurrence of the selected word (see "The Find Function" on page 6-29).
- Different** Only when Data Source field is *Compare*. Moves the cursor from one difference between new and reference data to the next in the direction the dial is turned. If a label field is highlighted, then the dial moves the cursor from difference to difference in that label only. If any other field is highlighted, the dial moves the cursor to the next difference in any label displayed.
- Equal** Only when Data Source field is *Compare*. Moves the cursor from one equality of new and reference data to the next in the direction the dial is turned. If a label field is highlighted, then the dial moves the cursor from equality to equality in that label only. If any other field is highlighted, the dial moves the cursor to the next equality in any label displayed.

List Data Representation

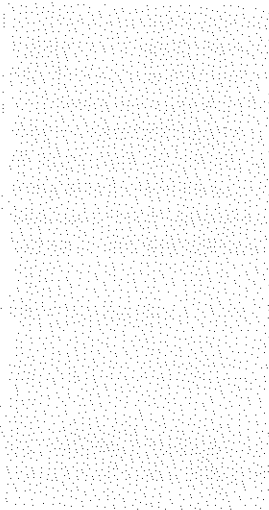

If *no data* was captured for a label present in the label area of the list display (e.g., because it had no channels assigned during the acquisition), then a *blank column* is shown in the display area.

If a label has more than one channel assigned and *some* of these channels had *no data* captured for them, then the column for the label shows a “?” for those positions corresponding to the “not captured” channels.

For binary base labels, these positions are per bit. For octal, hexadecimal and Ascii base labels, a “?” is shown for each digit/character in which such a channel appears. For decimal labels, the full width of the column is filled with question marks.

For labels with an Ascii base, non-printable characters, out of the range 32 (20 hex) through 127 (7E hex), are shown as a dot.

The Find Function

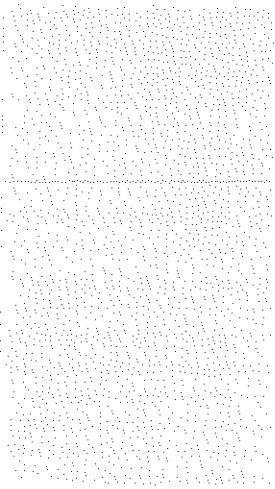

The find function is initialized by selecting “Find” in the *Dial Mode* field. This causes an extra row containing the *Find* fields to appear below the label base row. By default, the values to be found are set to “don’t care”, i.e., x’s. These values also match “?” values as described above.

You can change the find values, per label, to those you want to search for. When the label base is binary, octal, hexadecimal or Ascii, you can specify parts of the search word to be x (as for trigger words on the Trace menu).

If a label is highlighted, then the dial moves the cursor from matching value to matching value on that label only. If a field in the display definition area (e.g. the Y-position field) is highlighted, the dial moves the cursor to the next combined match of all labels of the find row visible on the display.

A find operation can be stopped with the *STOP* key.

DISPLAY													Sep 9 1991 02:21p	
Analyzer 1	Disa: None	Y: +0002	R: +0001	S: +0005	Spec Fncs:									
State: New	Dial: Y	Mode: Find	R-S: -0004											
Label: output	Time	clock in	o1	o2	o3	o4	o5	o6	o7	o8	o9	o10	o11	o1
Base: +Hex	Abs		+H	+H	+H	+H	+H	+H	+H	+H	+H	+H	+H	+H
Find: 00x			x	x	x	x	0	0	0	0	0	0	0	0
-0005 ffa	- 370ns	✓	0	1	0	1	1	1	1	1	1	1	1	1
-0004 ffb	- 295ns	✓	1	1	0	1	1	1	1	1	1	1	1	1
-0003 ffc	- 225ns	✓	0	0	1	1	1	1	1	1	1	1	1	1
-0002 ffd	- 150ns	✓	1	0	1	1	1	1	1	1	1	1	1	1
-0001 ffe	- 75ns	✓	0	1	1	1	1	1	1	1	1	1	1	1
T 0000 fff	+ 0ns	✓	1	1	1	1	1	1	1	1	1	1	1	1
R +0001 f80	+ 70ns	✓	0	0	0	0	0	0	0	0	1	1	1	1
Y +0002 001	+ 145ns	✓	1	0	0	0	0	0	0	0	0	0	0	0
+0003 002	+ 220ns	✓	0	1	0	0	0	0	0	0	0	0	0	0
+0004 003	+ 295ns	✓	1	1	0	0	0	0	0	0	0	0	0	0
S +0005 004	+ 365ns	✓	0	0	1	0	0	0	0	0	0	0	0	0
+0006 005	+ 440ns	✓	1	0	1	0	0	0	0	0	0	0	0	0
+0007 006	+ 515ns	✓	0	1	1	0	0	0	0	0	0	0	0	0
+0008 007	+ 585ns	✓	1	1	1	0	0	0	0	0	0	0	0	0
+0009 008	+ 660ns	✓	0	0	0	1	0	0	0	0	0	0	0	0
+0010 009	+ 730ns	✓	1	0	0	1	0	0	0	0	0	0	0	0

"Time" Label

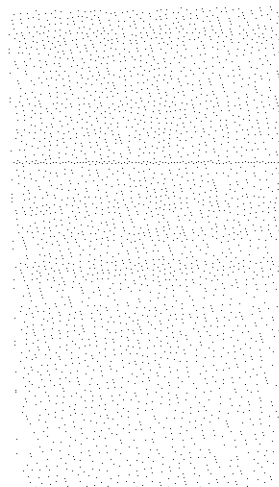

A special label, called "Time", is available in list displays. In this column, the time instant at which the sample was captured is shown. This time instant may be shown relative to the next sample (Base: Rel) or absolute with respect to T_0 (Base: Abs).

Notes:

1. If the samples displayed on a line originate from different clocks (due to the specification of "display on same line as" in the "Label attributes" menu) then the time value shown is that of the "first clock". That is, of the clock specified in the *display on same line as* field. (Compare Chapter 4, "State Clocks": "Display on Same Line as").
2. The "Time" label can be operated on as a normal data label. Thus it can be deleted, added, changed, etc. as described in "Selecting Labels for Display" beginning on page 6-16).

"Level" Label

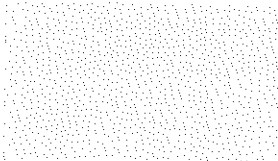

A special label, called "Level" is available in list displays. This label can be added as described in "Selecting Labels for Display" beginning on page 6-16. The values shown for this label tell you at which level the sequencer was when the data shown on that line was captured.

Label Base

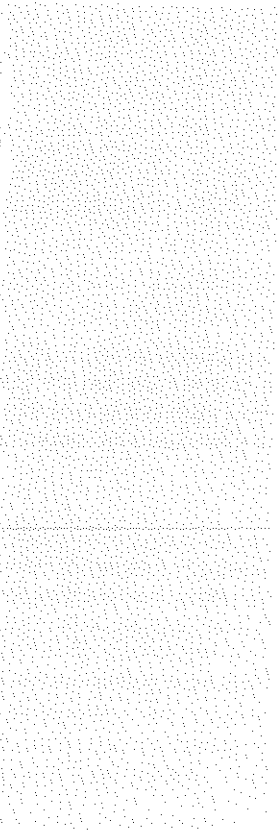

The *Base* field below a label shows in which base the data for the label is displayed, and allows it to be changed.

Data labels may be shown in binary, octal, decimal, hexadecimal, or Ascii. Time labels are shown as Abs (Absolute time from T₀) or Rel (Relative time from the previous line).

The base (including the polarity) is shown as two characters when the associated pattern definition (below) is two or less characters wide, and as four characters otherwise. The character used is the first character of the base name (B, O, D, H or A).

The + or - character reflects the polarity of the signal set on the Format menu. It is for information only and cannot be changed here.

For Clocks either a tick (✓) or nothing is displayed. A tick indicates that the samples on that line were captured by that clock.

Note: You cannot split bus labels into separate channels on the state display, but by selecting "binary" as the label base, you can see all channel values separately.

Disassembly

If a disassembler is loaded, the *Disa* field in the display definition area of the state list can be toggled to switch disassembly "On" or "Off". Furthermore, a *Disassembler parameters* field is added to the display definition area of the state list display. Using this field, a popup menu can be selected on which different disassembler parameters can be set. The parameters control which state samples are shown, and the disassembly process.

See "Disassembler Parameters Menu" in the *PM 3580/PM 3585 Reference Guide* for more detailed information on disassembler parameters. See Chapter 7, "Disassemblers" for general information on disassemblers, and the appropriate microprocessor support documentation (supplied separately as an appendix of this manual) for specific information.

If disassembly is "On", a special label, "Processor instructions", is added to the state list display. The results of the disassembly are shown in this column.

Note that, if no disassembler is loaded, the *Disa* field shows "None" and is not selectable.

Disassembly is only available on state list displays. The *Disa* field does not appear in the header area of any other display.

Split Screen

You can split the screen horizontally into two equally-sized windows. In each of these two windows you can display any data you want. For example, state list data in one, and timing waveform data in the other, or timing waveforms in both windows, with one showing the beginning of a measurement, and the other showing the end of the same measurement.

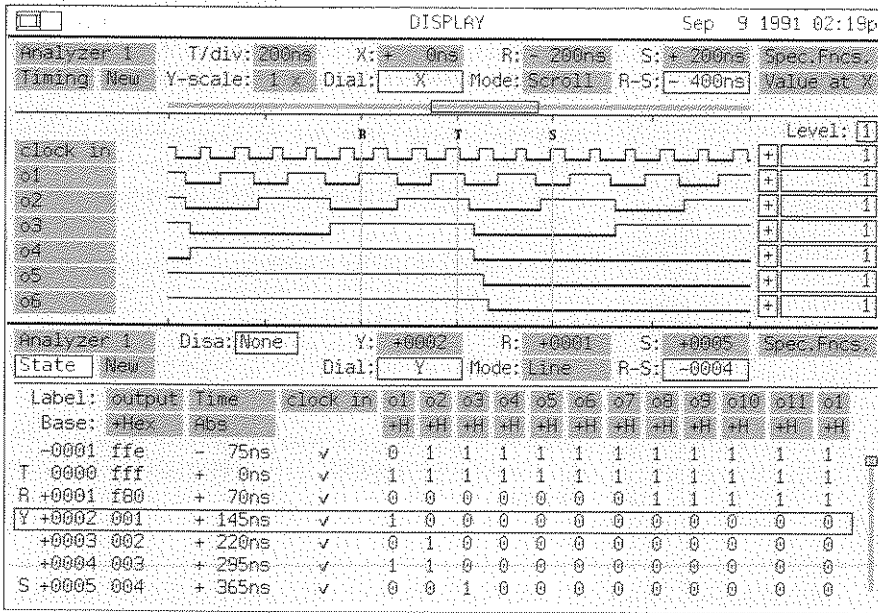

Creating a Split Screen

To create a split screen go to the *Analyzer Name* field or *Data Type* (State/Timing) field and press the *INSERT* key. This causes the lower part of the display to be replaced by a second window containing alternative data (as shown above).

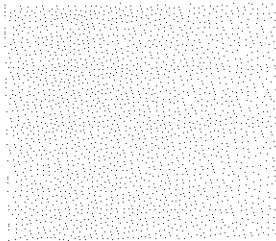

The first time a split screen is created, the data shown is determined by what type of data has been acquired, and the settings of the *Data stored* field on the Trace menu. New data will be shown either from the other analyzer or of a different type (state or timing) than that already shown. The next time a split screen is created the data type and form that was most recently "hidden" will again be displayed.

Deleting a Window

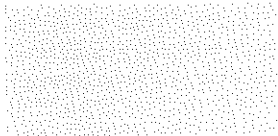

To delete a window of a split screen, go to the analyzer name field shown in that window and press the *DELETE* key. The complete screen is now again available for the remaining window.

Active Window

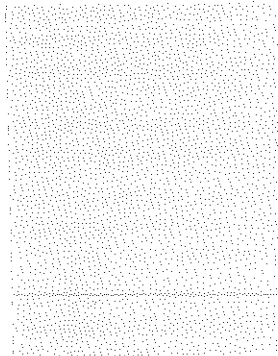

Only one window can be active at the same time (*i.e.*, the dial operates only on that window, unless Coscrolling is on). The currently active window is that window in which one of the selectable fields is highlighted.

As with all fields, you can use first letter select to position the cursors in the data. If you type, respectively, R or S on the R or S cursor fields the cursor value from the other window is set. Similarly in the special case when you have two of the same window type (waveform or list) typing X (or Y) on the X (or Y) cursor select field sets the corresponding value from the *other* window.

Moving Between Windows

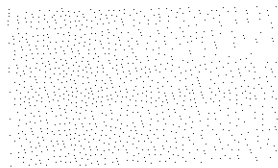

You can move between the two windows by pressing the *DISPLAY* key.

You can also move between the two windows by using the up and down arrow keys as appropriate.

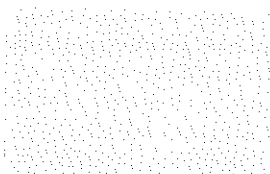

Note that if the upper window contains a timing waveform display, pressing the down arrow key while on the last label displayed will scroll the labels if more labels are still available. Only when on the last available label displayed, will pressing the down arrow key move you to the lower window.

Coscroll

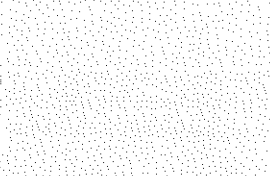

The data shown in the two windows of a split screen may be scrolled together or separately. This is controlled by the *Coscroll* field on the Display Special Functions popup menu. This menu is popped up by pressing *SELECT* on the *Special Functions* field ("Spec. Fncs.") which is present in the display definition area.

When *coscroll* is on, movement of an X or Y cursor in one display causes a corresponding movement of the X or Y cursor of the other display.

When you switch *coscroll* on, the analyzer asks you whether you want the X and Y cursors to be set to the same position (i.e., to the position of the cursor in the window where you selected *Special Functions*). If you answer "Yes", the cursors will be aligned. Otherwise, the initial offset between the cursors remains constant during *coscroll*.

In the *Display Special Functions* menu, you can additionally specify (with the *Coscroll* field) whether *coscrolling* is to be on the basis of "Times or Samples".

When "Times" is specified the data in both windows will scroll by the same time increment dialled in the active window (list displays will only actually move at the corresponding time-stamp values). This case typically applies when simultaneously acquired state and timing data are to be correlated. A more complex example would be synchronized scrolling of data acquired from a two-processor (or processor-bus) measurement using both analyzers. Then the activity on one processor could always be correlated with the corresponding activity on the other.

Coscrolling on the basis of "Samples" causes the data in the two windows to scroll by the same sample increments dialled in the active window. This typically applies when two acquired occurrences of a routine (separated in time) are to be correlated. You might be examining these two occurrences to see if the program flow was the same. Alternatively, you could compare ("New") data captured at a different speed with ("Ref") data captured at a different speed. For example if you want to test your circuit using a faster version of the microprocessor.

Although coscrolling on samples will typically be used with two state windows, it can also be used to compare timing patterns. For example, to see if an RS-232 serial bit stream contains the same information at 38.4 kbaud as at 19.2 kbaud.

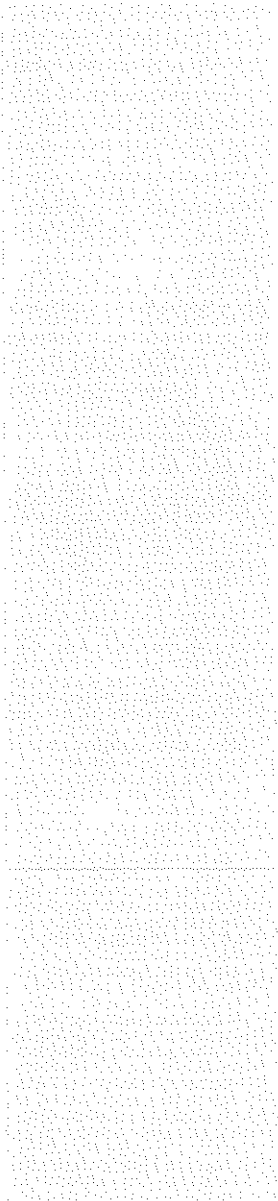

Chapter 7

Disassemblers

- Disassembly 7-2
 - Disassembler Packages 7-2
 - Microprocessor Adapters 7-2
- Loading a Disassembler 7-3
- Disassembler Setup 7-3
- Instruction Representation 7-5
 - Instruction Mnemonics 7-5
 - Operand Field 7-5
- Disassembler Parameters 7-6
 - Display Options 7-7
 - Translation Options 7-9
- Activating/Deactivating the Disassembler 7-10

Disassembly

When you work on "simple" clock-driven digital circuitry, timing and state information usually are enough to let you understand what is going on.

However, if you are testing a microprocessor-controlled board, the task is more difficult.

In addition to observing the signals, you must also understand and trace the program executed by the microprocessor. This means that you must translate the state data information into a more understandable form, especially for the software engineer.

Disassembly is a tool that can be used to translate the numbers of the state list back into a list of assembly instructions.

Disassembler Packages

With the PM 3580/PM 3585 you can order several disassembler packages, each consisting of a special microprocessor adapter and a floppy disk containing the appropriate disassembler software.

Microprocessor Adapters

The microprocessor adapters have been designed such that a minimum number of pods is required, thus leaving a maximum number of pods on the analyzer available for measuring other signals.

Furthermore, these adapters, whenever possible, have been designed such that the microprocessor timing data can also be captured using them ("passive adapters"). Combined with the Dual Analysis Per Pin architecture of the PM 3580/PM 3585, this allows you to capture both state and timing data of the processor simultaneously using the adapter.

For a general overview of microprocessor adapters, please refer to Chapter 8, "Probing" in this manual. The number of microprocessors supported is continuously

growing. You can obtain an up-to-date list of all microprocessors supported from your local Fluke/Philips sales representative.

Loading a Disassembler

Loading a disassembler into your logic analyzer is simple and straightforward.

Put the floppy disk with the appropriate disassembler in the floppy disk drive. (Disassembler files have names with the extension ".DIS".) Go to the Configuration menu and press *SELECT* on the field called "Option". A list appears on the screen showing all the disassemblers available on the floppy disk. Highlight the disassembler you want to be loaded and press *SELECT*.

The disassembler software and the associated setup are then loaded.

Disassembler Setup

After the disassembler has been loaded, it automatically configures the Logic Analyzer as required. That is, pods* are assigned if necessary, all label and clock assignments (including attributes) are made in the Format menu, and the Display menu is updated. As an example the Format menu as set up by the 68000 disassembler is shown on the next page.

As the disassembler is being loaded, it is checked whether sufficient resources (*e.g.*, pods, labels and clocks) are free. Furthermore, if you already had assigned clocks, labels or both to channels in the Format menu, you are asked whether these assignments should be deleted or left intact. If the number of the resulting free resources is sufficient, the disassembler is loaded. If not, you are notified, and the disassembler is not loaded, except as noted below.

* The disassembler does not require the pods assigned to the analyzer to be adjacent.

Note: The disassembler setup files contain settings for all microprocessor signals, including those which are not necessary for disassembly. If only sufficient resources are available for those signals required by the disassembler, the disassembler is still loaded. Setups for the other microprocessor signals will not then be loaded.

Analyzer 1		POD 4		POD 3		POD 2		POD 1	
Labels	Pol	TTL	TTL	TTL	TTL	TTL	TTL	TTL	TTL
LDS_CLK	+								
Qualified by:									
LDS_CLK	+								
Qualified by:									
DCTRL	+					III			
FC2_0	+					III			
ADDRESS	+						IIIIII	IIIIII	IIIIII
DATA	+			IIIIII	IIIIII				
R/WIN	+					I			
BGN	+								
BRN	+								
HALTN	+								
BERPN	+								
EGACKN	+								
IPL2_ON	+						III		
DTACKN	+								
ASN	+								
WMAN	+								

Instruction Representation

Instruction Mnemonics

Instruction mnemonics are displayed in capitals according to the specification of the processor's manufacturer. The mnemonics are shown with a suffix indicating the operand size. For these suffixes the following notation is used:

"B" : Byte
"W" : Word
"D" or "L" : Double-Word or Long-Word

Note: For 8-bit microprocessors these suffixes are not necessary, so are not shown.

Operand Field

In the operand field of an instruction, the operands are displayed in the same order as specified by the manufacturer.

Operand Values

The operand values are shown according to the following rules:

Signed operand parts: shown as decimal numbers with sign.

Unsigned operand parts: shown as hexadecimal numbers.

Immediate operands: are preceded by the "#" symbol.

Absolute long pointer addresses:
are preceded by the "@" symbol.

Target Addresses

Target addresses for both conditional and unconditional program transfers (jumps, branches etc.) are calculated whenever possible. Addresses calculated by the disassembler are then shown as hexadecimal numbers enclosed in braces ("{" and "}"), and concatenated to the operand field.

Bus Transfers and Disassembler Status

For bus transfers additional strings indicate the type of bus transfer. The following strings are used:

mr	Memory read.
mw	Memory write.
ior	I/O read.
iow	I/O write.
(unrel.)	Unrelated; shown in combination with mr, mw, ior or iow. Indicates that no corresponding instruction was found for this transfer.
opc	Opcode fetch.
unused opc	Fetch of unused opcode.
not disa	Sample captured with a state clock which is not defined for the current disassembler.
corrupted state	Used for bus transfers that, in order to represent a complete state, need one or more extra samples which, however, are not available.
***	Disassembler lost synchronization status.
Specific	Different strings indicating special actions. Examples of these kind of strings are: "int.ack", "RESET", "BUS ERROR", "Vector read", etc..

Disassembler Parameters

After a disassembler has been loaded, an extra field, *Parameters*, becomes visible in the state list display.

Pressing *SELECT* on this field shows a popup menu on which different disassembler parameters can be set, which further control the disassembly process.

A disassembler parameter popup menu is shown below.

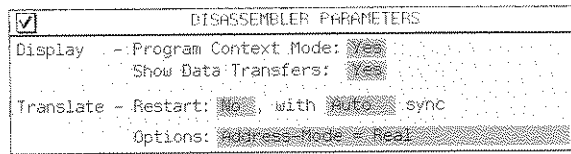

The *Options* field is only present on this popup menu for those disassemblers which have additional options. This field is described, when appropriate, in the microprocessor support package documentation (appendices to this manual).

The fields on the Disassembler Parameters menu are grouped in two sections:

- Display** This controls which state samples are shown.
- Translate** This controls the disassembly process.

Display Options

The display options fields together determine which disassembled instructions are displayed.

Program Context Mode

The *Program Context Mode* field determines if the instructions are shown in raw mode or analyzed by the disassembler and displayed in context. If program context mode is chosen, the disassembler filters out irrelevant instructions and arranges instructions in the order they were executed.

Irrelevant instructions are those near program transfers (e.g., jumps or branches) or program exceptions, fetched but not executed, and those related to state samples captured with external clocks not defined by the disassembler.

The two Display menus on the next page show the output of the Disassembler with the *Program Context Mode* respectively on ("Yes") and off ("No").

Program Context Mode: Yes

DISPLAY										Jan 1 1990 02:37p	
Analyzer 1		Disa: On		Y: 0018	R: 0009	S: 0014	Spec. Fncs.				
State	New	Parameters		Dial: Y	Mode: Line	R-S: [-9670ns]					
Label:	DSCtrl	PC2.0	ADDRESS	DATA	68000	Instructions	Time				
Base:	+Hex	+Hex	+Hex	+Hex	Abs						
	0007	4	6	00071c	46fc	MOVE	#2100,SR	+13.5us			
R	0009	4	6	00071e	2100			+17.0us			
	0011	4	6	000720	4efa	JMP	(-14,PC) (000714)	+21.3us			
	0012	4	6	000722	fff2			+22.9us			
	0013	4	6	000714	1212	MOVE.B	(A2),D1	+25.1us			
	0015	6	5	004000	00	mr		+26.2us			
S	0014	4	6	000716	3a81	MOVE.W	D1,(A5)	+26.6us			
	0017	0	5	ff8002	ff00	mw		+31.6us			
	0016	4	6	000718	3415	MOVE.W	(A5),D2	+29.8us			
	0019	4	5	ff8002	ff00	mr		+34.7us			
Y	0018	4	6	00071a	1682	MOVE.B	D2,(A3)	+33.2us			
	0021	2	5	004002	00	mw		+38.2us			
	0020	4	6	00071c	46fc	MOVE	#2100,SR	+36.3us			
	0022	4	6	00071e	2100			+38.7us			
	0024	4	6	000720	4efa	JMP	(-14,PC) (000714)	+44.1us			
	0025	4	6	000722	fff2			+45.7us			
	0026	4	6	000714	1212	MOVE.B	(A2),D1	+47.8us			
	0028	6	5	004000	00	mr		+51.0us			
	0027	4	6	000716	3a81	MOVE.W	D1,(A5)	+49.4us			
	0030	0	5	ff8002	ff00	mw		+54.4us			

Program Context Mode: No

DISPLAY										Jan 1 1990 02:40p	
Analyzer 1		Disa: On		Y: 0018	R: 0009	S: 0014	Spec. Fncs.				
State	New	Parameters		Dial: Y	Mode: Line	R-S: [-9670ns]					
Label:	DSCtrl	PC2.0	ADDRESS	DATA	68000	Instructions	Time				
Base:	+Hex	+Hex	+Hex	+Hex	Abs						
	0008	2	5	004002	00	mw		+15.4us			
R	0009	4	6	00071e	2100	opc		+17.0us			
	0010	4	6	000720	4efa	unused opc		+18.5us			
	0011	4	6	000720	4efa	JMP	(-14,PC) (000714)	+21.3us			
	0012	4	6	000722	fff2	opc		+22.9us			
	0013	4	6	000714	1212	MOVE.B	(A2),D1	+25.1us			
S	0014	4	6	000716	3a81	MOVE.W	D1,(A5)	+26.6us			
	0015	6	5	004000	00	mr		+26.2us			
	0016	4	6	000718	3415	MOVE.W	(A5),D2	+29.8us			
	0017	0	5	ff8002	ff00	mw		+31.6us			
Y	0018	4	6	00071a	1682	MOVE.B	D2,(A3)	+33.2us			
	0019	4	5	ff8002	ff00	mr		+34.7us			
	0020	4	6	00071c	46fc	MOVE	#2100,SR	+36.3us			
	0021	2	5	004002	00	mw		+38.2us			
	0022	4	6	00071e	2100	opc		+38.7us			
	0023	4	6	000720	4efa	unused opc		+41.3us			
	0024	4	6	000720	4efa	JMP	(-14,PC) (000714)	+44.1us			
	0025	4	6	000722	fff2	opc		+45.7us			
	0026	4	6	000714	1212	MOVE.B	(A2),D1	+47.8us			
	0027	4	6	000716	3a81	MOVE.W	D1,(A5)	+49.4us			

Show Data Transfers

The second field, *Show Data Transfers*, determines if the disassembler should filter out state samples representing memory or I/O activity. If these are displayed, and the microprocessor has a pipeline architecture, in Program Context Mode these samples are shown immediately following the instructions that caused them. The upper figure on the next page illustrates this also. Specifically look at the order of the sample numbers and the location of the data transfer samples shown (mr and mw).

Translation Options

Restart

The fields relating to translation are *Restart* and *Synchronization*.

Restart determines whether a new translation (disassembly) should be performed on the current measurement as soon as the disassembler parameters menu is closed.

Synchronization

The *Synchronization* field, and the other fields that may subsequently appear on that line, determine how the disassembler searches for proper instruction starting points.

Automatic Synchronization

For automatic synchronization, the disassembler starts at the earliest point in memory, and keeps correcting itself until a properly synchronized disassembly is achieved.

Manual Synchronization

For a manually synchronized disassembly, the disassembler starts at the instruction you set the Y cursor to.

You can define where on the bus the disassembler takes the starting point for disassembly using the *At Y* fields. This, however, only applies to microprocessors whose instructions can start at an address that is not a multiple of the data bus width. Each of the Xs in the *At Y* fields represents a nibble (4 bits). The number of Xs shown in each field depends on the minimum size the microprocessor uses to fetch opcodes. You toggle the field which is to be the starting point to show Xs. The other fields remain, or become, blank.

Activating/ Deactivating the Disassembler

After a disassembler has been loaded, disassembly can be switched on and off using the field called *Disa* in the state data display menu.

When disassembly is "On", the state display shows the program flow stored in the acquisition memory. When disassembly is "Off", the normal state data is shown.

Note that, if no disassembler has been loaded, the *Disa* field shows "None" and is not selectable.

Chapter 8

Probing

The Pod System	8-2
Front Ends	8-2
Probe Impedance	8-3
Pod Cable	8-3
Standard Front End	8-4
Microprocessor Adapters	8-6
RC Connectors	8-7
Adapter Types	8-7
Disassembler and Setting Files	8-8
RC Connectors	8-9

The Pod System

The link between the logic analyzer and the system under test is formed by the pod system which consists of two parts:

- the pod cable,
- the front end.

The pod system is a passive probing system, and therefore lightweight and easy to handle. The pod cable and front end together with the internal logic of the analyzer form a balanced system.

Front Ends

Different types of front ends may be distinguished:

- Standard front end
- Microprocessor adapters
- RC connectors

Standard front ends and pod cables are supplied with your instrument. Microprocessor adapters and RC connectors can be ordered as separate options.

The photograph below shows the pod cable with the standard front end attached.

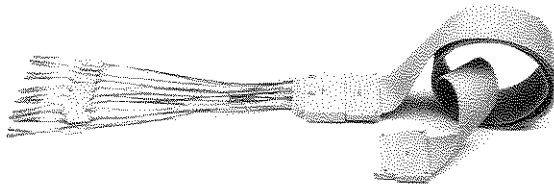

CAUTION

All front ends described contain RC compensating networks, using the pod cables without RC compensating networks can damage your instrument.

CAUTION

Signal ground is connected to the Analyzer's chassis ground.

Probe Impedance

The probe impedance of the pod system depends on the type of front end used. Typical values for the probe impedance are:

- Standard front end: 200 k Ω /7 pF
- Microprocessor adapters: 200 k Ω /15 pF
- RC connectors: 200 k Ω /7 pF
(excluding traces on PCB.)

Pod Cable

The pod cable is a specially-designed cable. It carries sixteen signals in parallel plus two power lines (+5V, -5V) at each side of the cable (see chapter 9, "User Hardware Specification": "Pod Cable Connector"). The cable is fully symmetrical.

The connector housing has a location in which the pod number stickers supplied with your instrument fit.

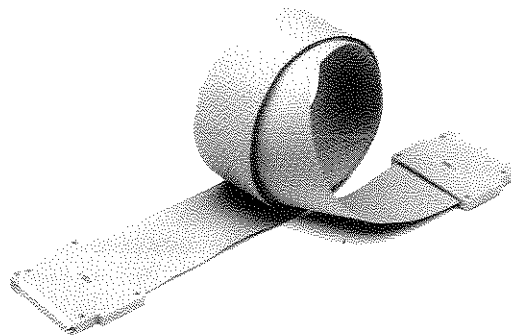

The best orientation for these stickers is with the bottom of the text closest to the cable (see photograph).

Standard Front End

The standard front end supplied with your instrument consists of a plug with detachable leads.

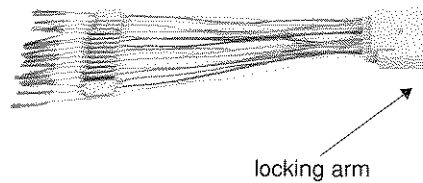

The plug contains locations at each side where you can attach pod number stickers for easy identification. The best orientation for these stickers is with the bottom of the text closest to the cable (see photograph).

Detachable Leads

Sixteen color-coded signal leads are available per standard front end, together with two short and two long ground leads.

To detach a lead from the plug, simply slide the tip of your finger under the locking arm of the lead, and push the lead out. When inserting a lead, push it until the arm locks in position.

Signal Leads

The colors of the signal leads match the color-coded sticker on the plug.

The signal leads are twisted pair type wires. One wire is connected to ground on the plug end.

The signal leads further contain an RC compensation network located near the end of the leads.

Ground Leads

The plug has four possible positions for ground leads: two in the middle and one at each side. These positions are marked by the symbol \perp on the color-coded sticker.

When you measure signals using the detachable leads, you have to connect one ground lead to a ground signal on your system under test for proper signal fidelity. For lower

Keying Mechanism

frequencies, a long ground lead can be used. For higher frequencies, however, you must use a short ground lead.

Connecting Leads to Signals

The signal leads will not fit in the ground lead positions on the plug due to the built-in keying mechanism. The same keying mechanism prevents you from connecting leads to the +5V, -5V power lines on the cable.

The leads can be connected to the signals you want to measure by means of the gray grabbers or red mini-clips supplied with your instrument.

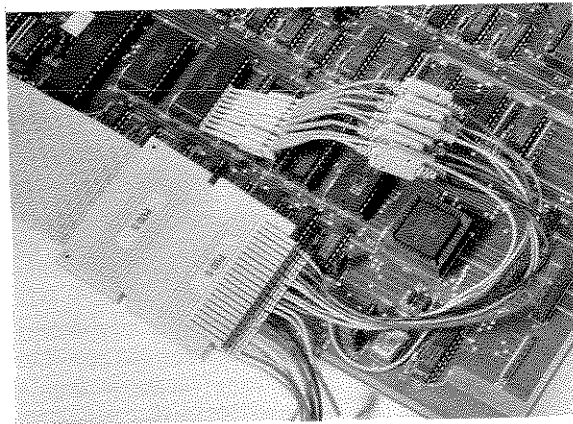

You can also directly connect a lead to a wire wrap pin on your board or to the pins of a measuring clip.

Microprocessor Adapters

To measure microprocessor signals you can use special microprocessor adapters. These adapters provide a convenient connection to all the signals of the specific microprocessor. The photograph below shows a number of different types of adapters.

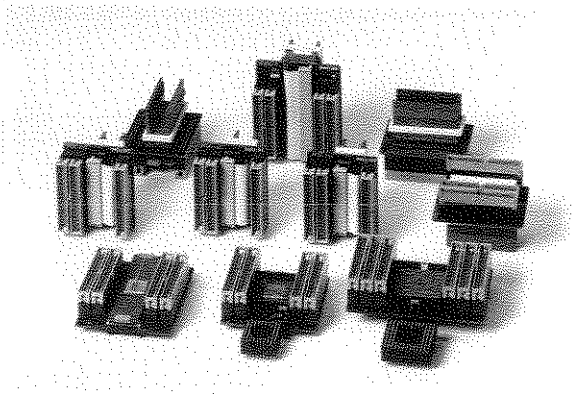

The number of microprocessors supported is continuously growing. You can obtain an up-to-date list of all microprocessors supported from your local Fluke/Philips sales representative.

The microprocessor adapters have been designed such that a minimum number of pods is required, thus leaving a maximum number of pods on the analyzer available for measuring other signals.

RC Connectors

The adapters contain special RC connectors to which the pod cables can be directly connected. The RC connectors contain the same RC compensation networks as the signal leads of the standard front end.

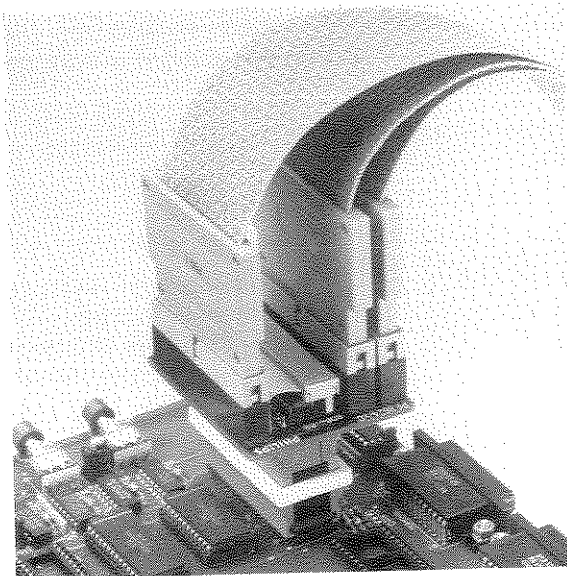

Adapter Types

DIP

Microprocessor adapters are available for DIP, PLCC, and PGA packages.

For the *DIP* packages, either a clip version (clip onto the chip), a socket version (insert between the microprocessor chip and its socket) or both are available. For the socket version extension sockets are separately available.

PGA and PLCC

PGA and *PLCC* versions are socket type. For these adapters, extension sockets are separately available.

Passive Adapters

The microprocessor adapters, whenever possible, have been designed such that both microprocessor state and

timing data can be captured using them ("passive adapters"). Combined with the Dual Analysis Per Pin architecture of the PM 3580/PM 3585, this allows you to capture both state and timing data of the processor simultaneously using the adapter.

Active Adapters

For those microprocessors where it is impossible for a passive adapter to capture all state data required for disassembly, a special "active" adapter is available. For these microprocessors also, passive adapters are available, intended for timing measurements.

Disassembler and Setting Files

Microprocessor adapters can be ordered in combination with disassemblers or separately.

In either case, the data to automatically configure the logic analyzer as required, *i.e.*, assigning pods as necessary, assigning labels and clocks (and their attributes) in the Format menu and proper display setup is provided with the adapter.

Disassembler file (.DIS)

If ordered in combination with a disassembler, this setup comes as an integral part of the disassembler. The disassembler can be loaded by using the *Option* field on the Configuration menu. See chapter 7, "Disassemblers" for more information.

Setting file (.SET)

If a microprocessor adapter is ordered without a disassembler, a floppy disk containing a setting file is provided with the adapter. This file can be loaded using the "Load" command available in the I/O menu of the analyzer. The file-name extension of a Setting file is ".SET".

RC Connectors

You can also incorporate the RC connectors as used on the microprocessor adapters in your own designs. You then mount the RC connectors directly on your boards.

The connectors, of course, require some board space. However, it is the most convenient way to probe your signals, since this solution creates the minimum adaption height and the most firm connection. The Logic Target, as described in the *Getting Started Guide* is one example of this type of probing.

The RC connectors can be separately purchased from your local Fluke/Philips sales representative, and come in sets of ten connectors (order number: PF 8603/20). These connectors are the same as the RC connectors used in the microprocessor adapters.

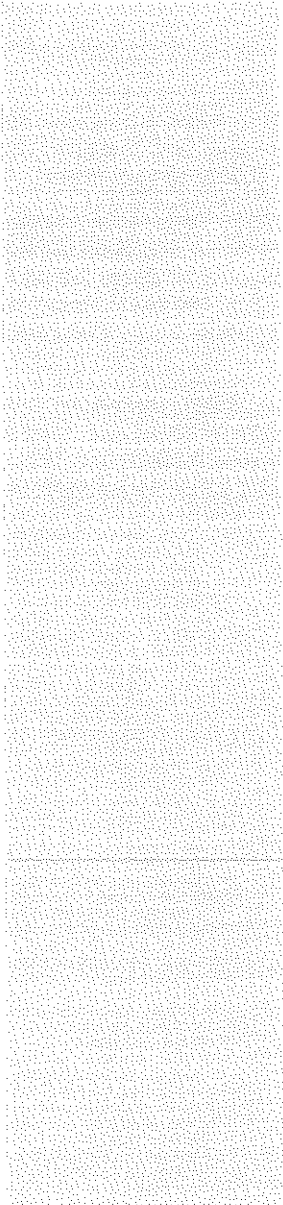

Chapter 9

User Hardware Specifications

Floppy Disk Drive	9-2
Centronics Connector	9-3
IEEE-488 Connector	9-4
RS232 Connector	9-5
Video Connector	9-6
Pod Cable Connector	9-7

This chapter describes the floppy disk drive specification and the specifications of the connectors on the back of the Logic Analyzer. For information on other hardware see the *Service Manual*.

Floppy Disk Drive

The floppy disk drive uses 3.5 inch IBM PC compatible disks of 1.44 MB or 720 KB:

1.44 MB disks:

- 80 tracks
- 18 sectors per track
- 2 sided.

720 KB disks:

- 80 tracks
- 9 sectors per track
- 2 sided.

Centronics Connector

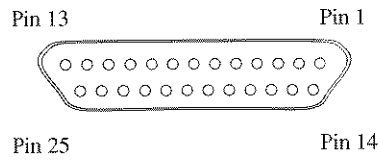

Pin	Signal	Pin	Signal
1	STROBE	10	ACKN
2	D0	11	BUSY
3	D1	12	Paper End
4	D2	13	Select
5	D3	14	Auto Feed
6	D4	15	not connected
7	D5	16	not connected
8	D6	17-25	GND
9	D7		

Timing Centronics Parallel Interface

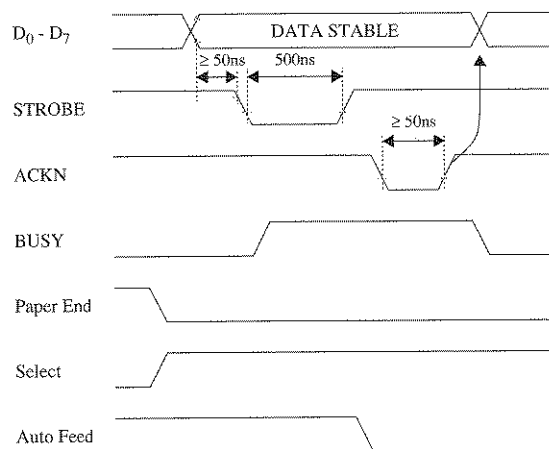

**IEEE-488
Connector**

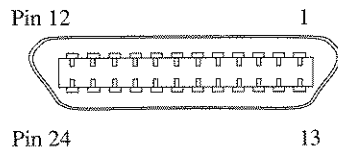

Pin	Signal	Pin	Signal
1	DI01	13	DI05
2	DI02	14	DI06
3	DI03	15	DI07
4	DI04	16	DI08
5	EOI	17	REN
6	DAV	18	GND
7	NRFD	19	GND
8	NDAC	20	GND
9	IFC	21	GND
10	SRQ	22	GND
11	ATN	23	GND
12	SHIELD	24	LOGICGND

RS232 Connector

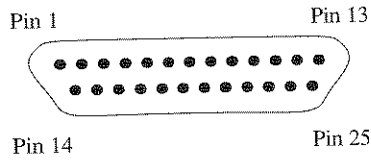

Pin	Signal	Pin	Signal
1	GND	5	CTS
2	TX	6	not connected
3	RX	7	GND
4	RTS	8-25	not connected

RS232-C compatible

Video Connector

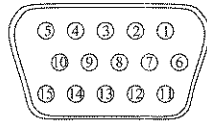

Pin	Signal	Pin	Signal
1	PX2	9	not connected
2	video	10	GND
3	PX1	11	SENSE
4	not connected	12	GND
5	GND	13	HSYNC
6	not connected	14	VSYNC
7	GND	15	not connected
8	not connected		

MVGA compatible

Pod Cable Connector

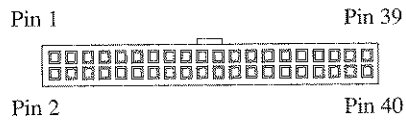

Pin	Signal
1	-5 V
2,4,6,...,38,40	GND
3	Data channel 0
5	Data channel 1
7	Data channel 2
9	Data channel 3
11	Data channel 4
13	Data channel 5
15	Data channel 6
17	Data channel 7
19, 21	GND
23	Data channel 8
25	Data channel 9
27	Data channel 10
29	Data channel 11
31	Data channel 12
33	Data channel 13
35	Data channel 14
37	Data channel 15
39	+5 V

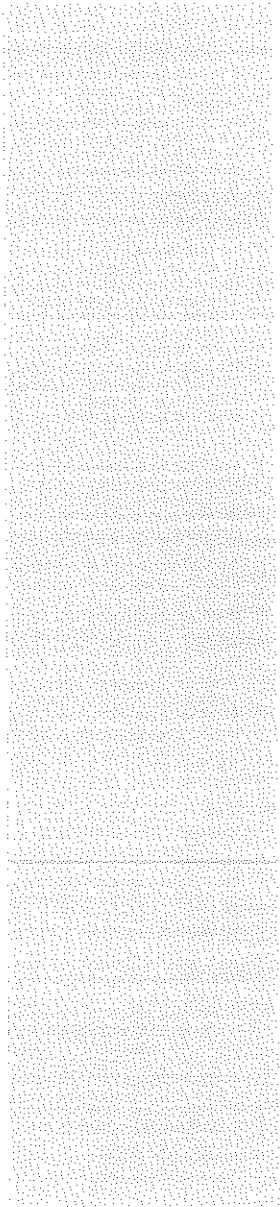

Chapter 10

File Formats

Hardcopy File 10-2
Header 10-2
Screen Image 10-2

Hardcopy File

Using the Print menu, you can store the currently visible screen on the floppy disk. Refer to Chapter3, "Menu Overview", section "The Print Menu".

The file created contains a Header immediately followed by the Screen Image.

Header

The Header of the hardcopy file consists of sixteen bytes B0...B15, with B0 being the first byte in the file.

These bytes are grouped as follows:

- B0...B3 : File type identification.
Fixed value 61,0A,59,26 hex.
- B4, B5 : Version number; currently 0.
- B6, B7 : The number of pixels per scan line.
- B8, B9 : The number of scan lines.
- B10, B11 : The number of bits per pixel; Currently 2.
- B12...B15 : The size of the second part of the file (the Screen Image) in bytes.

The first byte mentioned for a group is the most significant byte in that group.

Screen Image

The screen is stored as a number of sequential scan lines. Each scan line represents one row of pixels and is rounded up to a multiple of 16 bits. Thus each scan line starts on a 2-byte boundary. Per pixel, two bits are used together to represent a color as follows:

- 00 = white
- 01 = light gray
- 10 = dark gray
- 11 = black

The first pixel is stored in the first two bits of a byte (i.e. the two most significant bits). The next pixel is stored in the following two bits etc.

For example, if the first four pixels of the screen image (upper left corner) are black, white, white, white, the first byte of the first scan line will read "C0" hex.

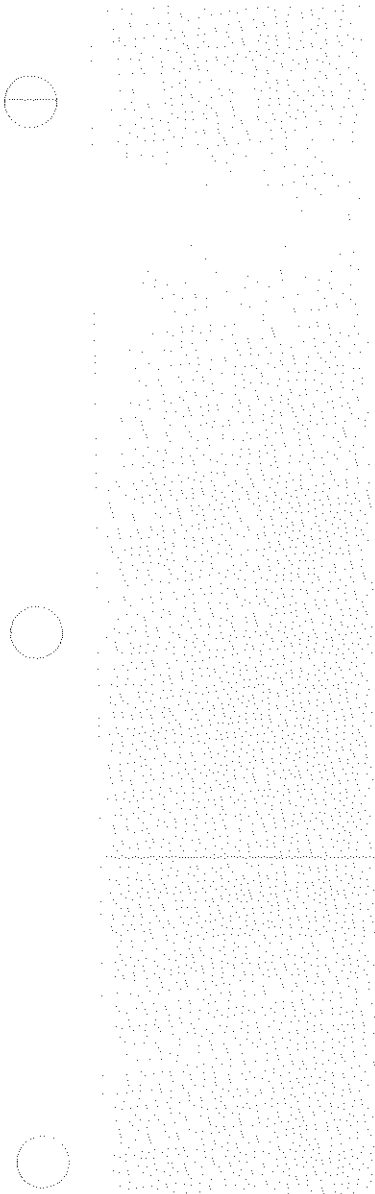

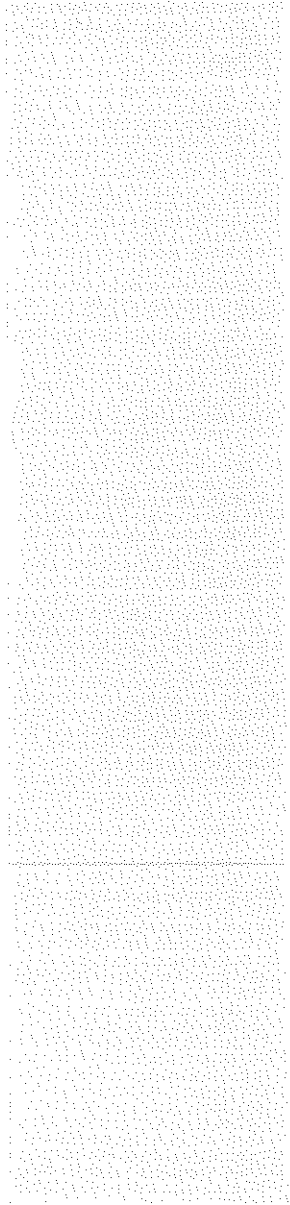

LOGIC ANALYZERS PM 3580 / PM 3585

Read the procedures for

Initial Inspection
Operator Safety
Installation

found on top of this documentation package **first**.

Then insert the description of these procedures as Chapter 11 after the "Safety and Installation" tab in the *PM 3580/PM 3585 User Manual*. You may then discard this page.

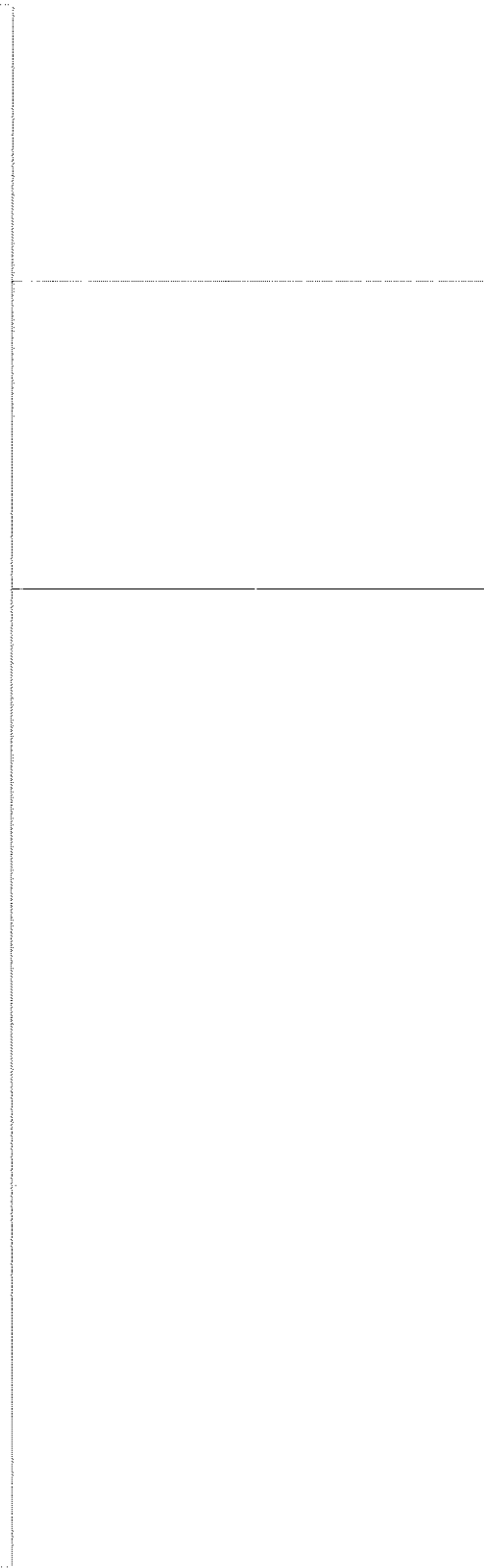
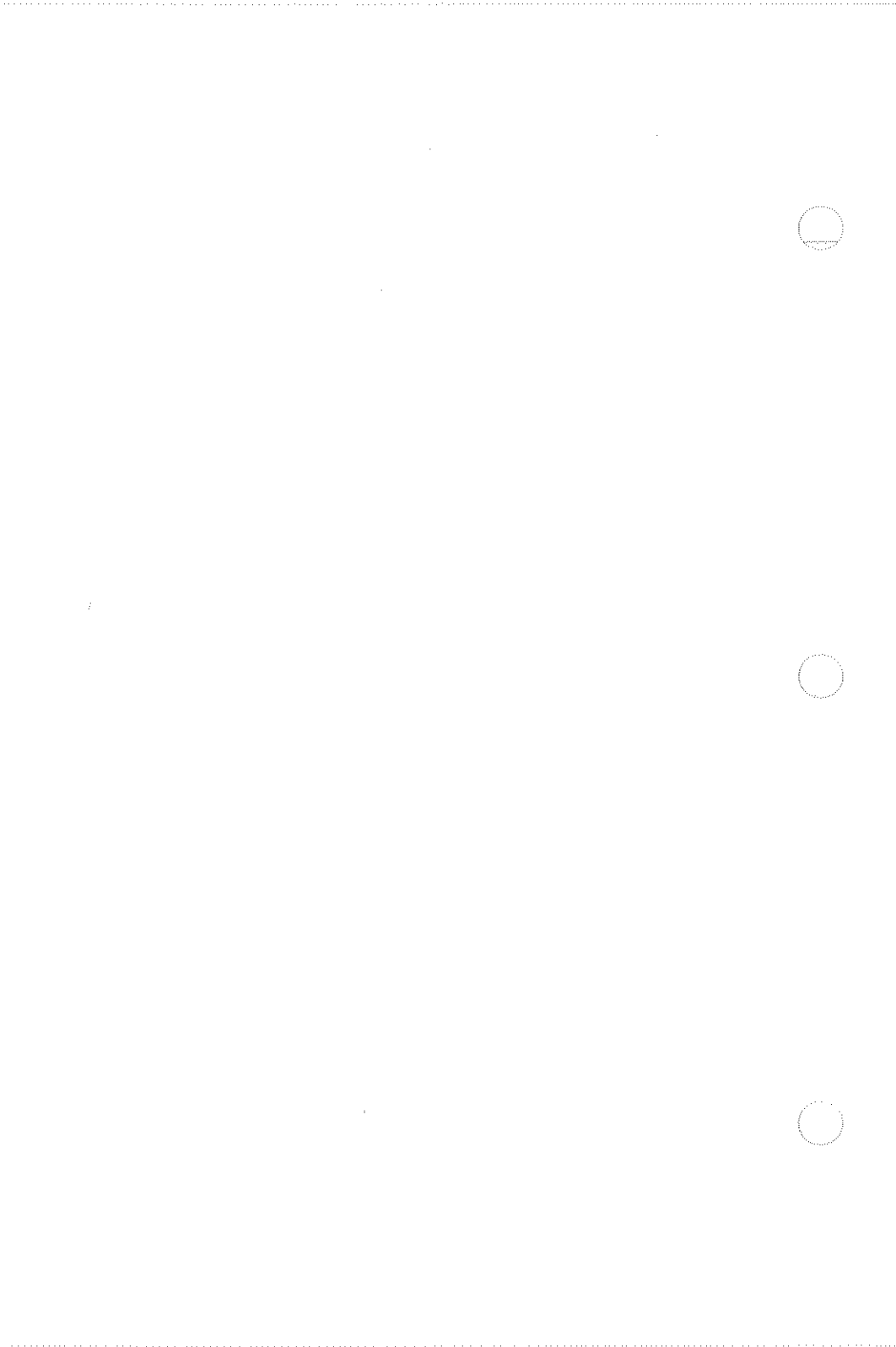

Chapter 11

Safety and Installation

Initial Inspection	11-2
Operator Safety	11-3
Safety Precautions	11-3
Caution and Warning Statements	11-3
Symbols	11-4
Impaired Safety Protection	11-4
Safety Notice	11-4
Installation	11-6
Working Position	11-6
Earthing	11-6
Setting the Line Voltage	11-7
Switching on the Logic Analyzer	11-9
Setting the Date and Time	11-10
Fluke/Philips Addresses	11-11
U.S.A.	11-24

Initial Inspection

Check the contents of the shipment for completeness and note whether any damage has occurred during transport.

If the contents are incomplete, or there is damage, a claim should be filed with the carrier immediately. Also the Fluke/Philips Sales or Service organization should be notified in order to facilitate the repair or replacement of the instrument or other parts. The list of Fluke/Philips addresses are published beginning on page 11-11.

Together with the Logic Analyzer PM 3580/30, PM 3580/60, PM 3585/60, or PM 3585/90 the following accessories should be included in the shipment:

Type Number	Description	Number ¹
PF 8666/20	Front cover with integrated accessory pouch.	1
PF 8690/00 ²	English manual set + system software (<i>Getting Started Guide, Reference Guide, User Manual, and Service Manual</i>).	1
2432 072 0000 ³	Power Cable.	1
PF 8600/20	16-channel Logic Pod.	2,4,4, or 6
4022 102 48731	Pod label sheet.	1
PF 8600/24	Gray, low-profile, mini-measuring clips.	40,80,80 or 120
PF 8669/20 ⁴	Logic target.	1
PF 86xx/xx ⁵	Microprocessor support package(s)	as ordered ⁵

Notes:

1. If more than one number is indicated in this column, the number of items included depends on the type number of your Logic Analyzer. The numbers, in order, relate to PM 3580/30, PM 3580/60, PM 3585/60, and PM 3585/90.
2. Depending on your country code, alternatively a German (PF 8690/20) or French (PF 8690/10) manual set and system software may be present instead.
3. Depending on your country code, alternatively a "European" (2432 073 00011) or country-specific power cable may be present.
4. The Logic target is included as standard for the U.S. versions only.
5. If a microprocessor support package was ordered with the Logic Analyzer, this package is also included in the shipment.

Operator Safety

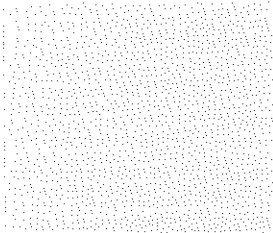

The following subsections contain information, warnings and cautions which must be followed to ensure safe operation and to retain the instrument in a safe condition. Read these carefully before installation and use of the instrument.

Adjustment, maintenance and repair of the instrument shall only be carried out by qualified personnel.

Safety Precautions

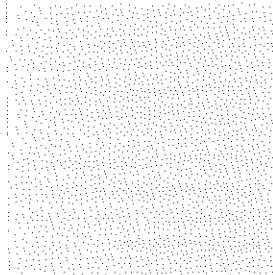

For the correct and safe use of this instrument it is essential that both operating and service personnel follow generally accepted safety procedures in addition to the safety precautions specified in this manual.

Specific warning and caution statements, where they apply, will be found throughout the manuals.

Where necessary, the warning and caution statements and/or symbols are marked on the apparatus.

Caution and Warning Statements

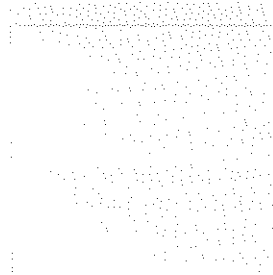

WARNING





Calls attention to a potential danger that requires correct procedures or practices in order to prevent personal injury.

CAUTION

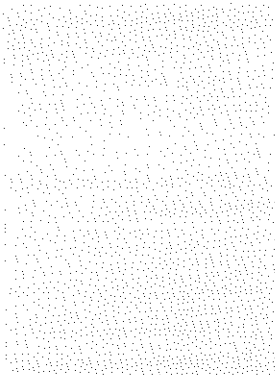
Is used to indicate the correct operating and maintenance procedures in order to prevent damage to, or destruction of, the equipment or other property.

Symbols



-  High Voltage (red) ≥ 1000 Volts
-  Live Part (black/yellow)
-  Read the operating instructions.
-  Protective earth (grounding) terminal.

Impaired Safety Protection

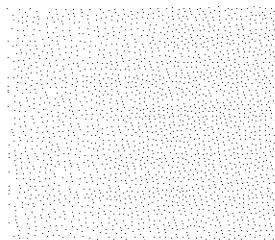

Whenever it is likely that safety-protection has been impaired, the instrument must be made inoperative and be secured against unintentional operation. The matter should then be referred to qualified technicians.

Safety protection is likely to be impaired if, for example, the instrument fails to perform the intended measurements or shows visible damage.

Safety Notice

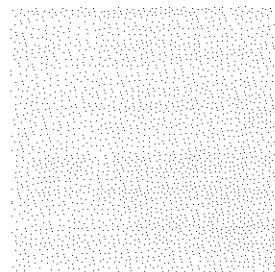

WARNING

The opening of covers or the removal of parts, except those to which access can be gained by hand, is likely to expose live parts and accessible terminals which can be dangerous to life.

The instrument **must** be disconnected from all voltage sources before it is opened for any adjustments, replacement, maintenance or repair.

Note that the capacitors inside the instrument can hold their charge even if the instrument has been disconnected from all voltage sources.

Any adjustment, replacement, maintenance or repair of the powered-up, opened instrument shall be avoided as far as possible, and, if inevitable, shall be carried out only by a skilled person who is aware of the hazard involved.

WARNING

For any adjustment, maintenance, replacement or repair the procedures and additional safety instructions contained in the *PM 3580/PM 3585 Service Manual* must be adhered to.

Installation

Before attempting to use the logic analyzer read this section carefully and complete the necessary procedures.

Working Position

Horizontal on bottom feet, vertical on rear feet and any intermediate angle. Check that the fan is running after power-up, and that the cooling air flow is unobstructed.

Earthing

Before any connection to the input connectors is made, the instrument must be connected to a protective earth conductor via the three-core mains cable; the mains plug must only be connected to a socket outlet provided with a protective earth contact. The protective action must not be negated by the use of an extension cord without protective conductor.

WARNING

Any interruption of the protection earth connector inside or outside the instrument or the disconnection of the protection earth terminal is likely to make the instrument dangerous. Intentional interruption is prohibited.

Before connecting the equipment to the mains of the building installation, the proper functioning of the protective earth lead of the building installation needs to be verified.

Setting the Line Voltage

Before plugging in the instrument make certain that it has been set to the local voltage.

Note: If the power plug has to be adapted to the local situation, such adaptation should only be done by a qualified technician.

WARNING

The instrument shall be disconnected from all voltage sources when a fuse is to be renewed, or when the instrument is to be adapted to a different line voltage.

The two possible settings are 110 V (90 V - 135 V supplies) and 220 V (180 V - 264 V supplies).

Note

The correct fuse should be used for each of the voltage settings:

- 220 V: 2 A/250 V slow.
- 110 V: 4 A/250 V slow.

This setting is determined by the voltage selector unit located at the rear of the instrument: see the figure below.

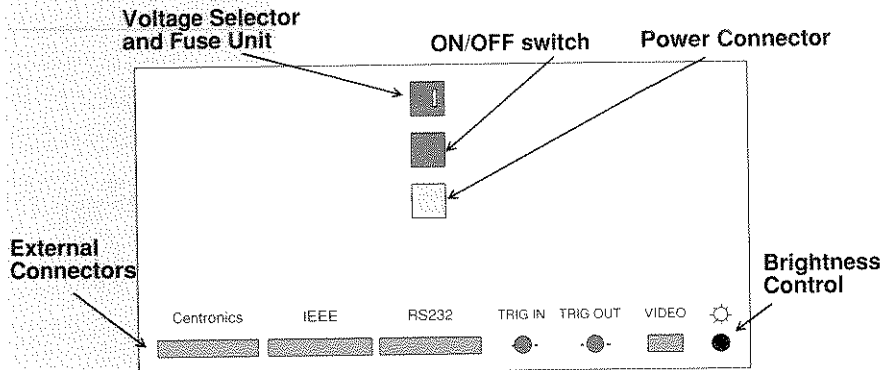

To change the setting, proceed as follows, with reference to the figures below:

- Disconnect the power supply from the instrument.
- Prize the voltage selector unit (1) from the rear of the instrument.
- Lift the retaining lug that holds the voltage selector (2) in the unit and then remove the selector.
- Rotate the voltage selector so that the required figure will be displayed in the window of the unit.
- Insert the fuse with the required rated current and of the specified type.
- Replace the complete unit in the reverse order of that of the removal procedure.

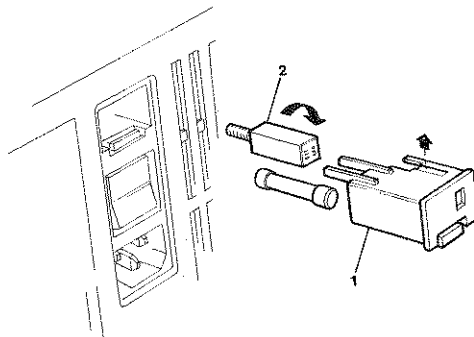
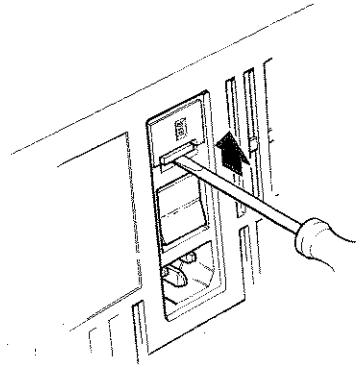

Switching on the Logic Analyzer

Ensure that the instrument has been set to the local line voltage.

- Ensure that the power cable is not connected to the power supply and that the power switch on the instrument is OFF.
- Plug the female end of the power cable into the instrument.
- Plug the power cable into an appropriate **earthed** power source.
- Remove the transport protector (if any) from the floppy disk drive by pushing the eject button.
- Switch on the instrument. This will cause the light on the floppy drive to illuminate and a start-up message to appear on the screen.
- Push the System disk (PF 8690) into the drive until it locks.

The system software is now loaded, including the auto-load file if present. After loading a calibration procedure is executed. This procedure ensures that the propagation delay is the same on all channels.

After successful completion of the calibration, the Configuration menu is displayed, and your system is ready for use.

Calibration

Brightness Control

Adjust the brightness of the screen, using the control located at the rear of the instrument (see the figure on page 11-7), to suit your requirements.

Power on Self-Test

Note: If you press any key during the power on sequence of the analyzer, it will perform a (15 minute) self-test and display the results of the test on the screen. After the self-test has been completed and is satisfactory, you can proceed to use the instrument.

Setting the Date and Time

A facility is available on the Utility disk to enable you to set the date and time, and the format of presentation, on the instrument. Refer to Chapter 12, "Utilities" on how to do this.

Fluke/Philips Addresses

Algeria
Bureau de Liaison Philips
24 rue Bougainville
El Mouradia, Alger
Tel: 60 14 05
TLX: 62221

Angola
Lusolanda Trading S.A.R.L.
C.P. 178
LUANDA
Tel: 244-2-372250
Fax: 244-2-373413

Antilles
Philips Antillana N.V.
(For Philips products)
Kaminda Michigan 4
PO Box 3523/3051
Willemstad, Curacao
Tel: 599-9-615277
Fax: 599-9-612772
TLX: 1047 PHINA

Argentina
Philips Argentina S.A.
(For Philips products)
Casilla Correo 3479
Vedia 3892
1430 Buenos Aires
Tel: 54-1-5414106/5417141
Fax: 54-1-7869818
Tel: 54-1-5422411/5422451*
TLX: 21359/21243

Coasin S.A.
(For Fluke products)
Virrey del Pino 4071 DEP E-1
1430 CAP FED
Buenos Aires, Argentina
Tel: (54) (1) 552-5248
TLX: (390) 22284 COASN AR

Australia/New Zealand
**Philips Scientific &
Industrial PTY Ltd.**
Test & Measurement Dept.
NZ Head Office
2 Wagner Place
PO Box 4021
Auckland 3
New Zealand
Tel: 09-894160
Fax: 09-862728
TLX: NZ 2395

Australia Head Office
**Philips Scientific &
Industrial PTY Ltd.**
Test & Measurement Dept.
Centre Court 25-27 Paul Street
North Ryde
Sydney New South Wales 2113
Tel: 02-888 0416
Tel: 02-888 8222*
Fax: 02-888 0440
TLX: AA 20165 philind ausnrsi

**Philips Scientific &
Industrial PTY Ltd.**
Test & Measurement
23 Lakeside Drive
East Burwood
Melbourne Victoria 3151
Tel: 03-235 3666
Fax: 03-235 3618

**Philips Scientific &
Industrial PTY Ltd.**
Test & Measurement
348 Torrens Road
Croyden
Adelaide South Australia 5008
Tel: 08-3482888
Fax: 08-3482813

* Service Center.

Philips Scientific & Industrial PTY Ltd.
Test & Measurement
299 Montagne Road
West End
Brisbane Queensland 4101
Tel: 07-8440191
Fax: 07-8448537

Philips Scientific & Industrial PTY Ltd.
Test & Measurement
1 Frederick Street
Belmont
Perth West Australia 6104
Tel: 09-277-4199
Fax: 09-277-1202

Austria
Philips Professionelle Elektronik GmbH
Marktbereich Test und Messgeraete
Gutheil Schoder Gasse 10
A 1102 Wien
Tel: 0222/60101 -0
Fax: 0222-6272165
TLX: 133129

Philips Professionelle Elektronik GmbH
Marktbereich Test und Messgeraete
Technischer Kundendienst
Triesterstrasse 64
1101 Wien
Tel: 0222-60101 ext. 818

Bahrain
Messrs. Mohamed Fakhroo & Bros
PO Box 439
Bahrain
Tel: 973-253529
Fax: 973-275996
TLX: 8679 alfaro bn

Bangladesh
Philips Bangladesh Ltd.
P.O. Box 62, Ramna 17/17
Bazar
DHAKA
Tel: 325081-5
TLX: 65668 PHIL BG

Barbados
Manning Wilkins on & Challenor
P.O. Box 176
Bridgetown
Tel: 436-6185
Fax: 809-426-7373
TLX: Mannings 2355 WB

Belgium
Philips Professional Systems S.A.
Test & Measurement Department
Tweestationstraat 80
1070 Brussel
Tel: 02-525 6692
Tel: 02-525 6694*
Fax: 02-230-2856*
Fax: 02-525 6483
TLX: 61511 belbrms

Bermuda
Holmes, Williams and Purvey
P.O. Box 444
Hamilton
Tel: 809-2955000
TLX: 3725 HWPBA

Brazil
Philips Medical Systems Ltda.
Av. Interlagos. N. 3493
04661 Sao Paulo S.P.
Tel: 55-11-5234811
Fax: 55-11-5244873

ATP Hi-Tek Electronica Ltda.
Al. Amazonas 422, Alphaville
06400, Barueri
Sao Paulo, Brazil
Tel: (55) (11) 4215477
Fax: (55) (11) 4215032
TLX: 1171413 HITK BR

* Service Center.

Brunei
Brunei (via Singapore)
(For Philips products)
Philips Project Development
(S) PTY Ltd.
Lorong 1, Toa Payoh
Singapore 1231
PO Box 340 Tao Payoh C.P.O.
Tel: 65-3502000
TLX: philips rs/21375

Rank O'Connor's, 5nd Bhd
(For Fluke products)
No. 8 Block D,
Sufri Shophouse Complex
Mile 1 Jalan Tutong
Bandar Seri Begawan
Negara Brunei Darussalam
Tel: (673) (2) 23109 or 23557
TLX: (799) BU 2265 RANKOC

Bolivia
E.P.T.A. INGENIERA S.R.L.
C.P. 20942
Calle Camoos No. 284
LA PAZ
Tel: 3-25952
TLX: 2518 EPTABV

Bulgaria
Interconsult
(Philips Service)
Bul. Jane Sandanski, blok 65
P.O. Box 42
1309 SOFIA
Tel: 359-2-200785

Canada
Fluke Electronics Canada Inc.
400 Britannia Rd. East Unit #1
Mississauga, Ontario
L4Z 1X9 Canada
Tel: (416) 890-7600
Fax: (416) 890-6866

Fluke Electronics Canada Inc.
1690 Woodward Drive
Suite 216
Ottawa, Ontario
K2C 3R8 Canada
Tel: (613) 723-9453
Fax: (613) 723-9458

* Service Center.

Fluke Electronica Canada Inc.
1255 Trans Canada Highway
Suite 120
Dorval, Quebec
H9P 2V4, Canada
Tel: (514) 685-0022
Fax: (514) 685-0039

Fluke Electronics Canada Inc.
101, 1144 - 29th Ave. N.E.
Calgary, Alberta
T2E 7P1 Canada
Tel: (403) 291-5215
Fax: (403) 291-5219

Chile
Philips Chilena S.A.
de Product Electr.
(For Philips products)
Avenida Santa Maria 0760
Casilla 2678
Santiago de Chile
Tel: 56-2-770038
Fax: 56-2-776730
TXL: 240239

Itronsa
(For Fluke products)
Casilla 16228
Santiago, Chile
Tel: (56) (2) 232-4308
Fax: (56) 2-2322694
TLX: (332) 346351

China, People's Republic of
Philips HongKong Ltd.
Site 7 ground floor, Whampoa
Garden
Hung Hom, Kowloon,
HongKong
Tel: 7735588
Fax: (852) 3345496
TLX: 43752 PHILH HX

Instrimpex - Fluke Service
Center
(For Fluke products)
Scite Tower Room 2101
22 Jiam Guo Man Wal Dajie
PO Box 9085
Beijing
People's Republic of China
Tel: 86 01 512-3436

Colombia
Industrias Philips de Colombia S.A.
(For Philips products)
Apartado Aereo 4282
Calle 13 No. 51-39
Bogota
Tel: 57 1-2600600
Fax: 57-1-2610139
TLX: philcolon 44776

Sistemas E Instrumentation, Ltda.
(For Fluke products)
Carrera 21, No. 39A - 21, Of. 101
Ap. Aereo 29583
Bogota, Colombia
Tel: (57) 232-4532
Fax: (57) 1-287-2248

Costa Rica
Electrocom
Apartado 7742
San Jose
Costa Rica
Tel: 53-0083/57
TLX: 3050 elecom cr

C.S.F.R.
Branch Office Brno*
Babickova 40
61300 BRNO
Tel: 42-2-377426
Fax: 42-2-377426
TLX: 62345 UFMB-C

Obnova Pamatek n.p.*
Na. Berance 2
16041 PRAHA 6
Tel: 42-2-594426/60351
Fax: 42-2-594426/377426
TLX: 123069 OBPA C

Cyprus
D. Ouzounian M. Soultanian & Co. Ltd.
PO Box 1775
45, Evagoras Avenue
Nicosia
Tel: 357-2-442220
Fax: 357-2-459885
TLX: 2315 cy automobil

Denmark
Philips A/S Test & Measurement
Prags Boulevard 80
DK 2300 Kobenhavn S
Tel: +45-32-882100
Fax: +45-31-571355
TLX: 31201

Ecuador
Philips Ecuador S.A.
Dpto. de Sistemas Medicos/
Prof.
Av. Amazonas
1188Y Cordero
QUITO
Tel: 593-2-565835
Fax: 593-2-564601
TLX: 22227 PHLPSQ-ED

Egypt
Philips Egypt Branch Middle East B.V.
10, Abdel Rahman el Rafie st.
PO Box 242
Dokki, Cairo
Tel: 20-2-3490922
Fax: 20-2-3492142
TLX: 22816 phegy un

Ethiopia
Philips Ethiopia
(Priv. Ltd. Co.)
Ras Abebe Areguay Avenue
PO Box 2566
Addis Ababa
Tel: 010-231-1-518300
Fax: 251-1-52845
TLX: 021319 phaddis

Finland
OY Philips AB
Test & Measurement
Sinikalliontie 3
PO Box 75
SF-02631 Espoo
Tel: +358 0 50261
Fax: +358 0 529558
TLX: 1248 11 Phil

* Service Center.

France

**S.A. Philips Industrielle
et Commerciale**
Division Science et Industrie
105 Rue de Paris, BP 62
93002 Bobigny Cedex
Tel: (1) 49428080
Tel: (1) 49428073*
Fax: (1) 49428100
TLX: 235546

Germany

**Philips GmbH - EWI
Head Office**
Miramstrasse 87
D-3500 Kassel
Tel: 0561-501466
Fax: 0561-501590
TLX: 997070

Philips GmbH - EWI
Martin Luther Strasse 3-7
D 1000 Berlin 30
Tel: 030-21006364
TLX: 185532

Philips GmbH - EWI
Wieselweg 5
D 4300 Essen 11
Tel: 0201-3610-245
Fax: 0201-3610265
TLX: 857-226

Philips GmbH - EWI
Th. Heuss Allee 106
D 6000 Frankfurt 90
Tel: 069-794093-31
Fax: 069-794093-91
TLX: 413611

Philips GmbH - EWI
Meiendorferstrasse 205
D 2000 Hamburg 73
Tel: 040-6797-278
Tel: 040-6797471*
TLX: 2116625

Philips GmbH - EWI
Oskar Messterstrasse 18
(For Fluke products)
D 8045 Ismaning
Tel: 089-9605-121
TLX: 21701380 phd

* Service Center.

Philips GmbH - EWI

Kilianstrasse 142
D 8500 Nuernberg 12
Tel: 0911-3603293
TLX: 21701 380 phd

Philips GmbH - EWI

Hoehestrasse 21
D 7012 Fellbach
Tel: 0711-5204-121
Tel: 0711-5204150*
Fax: 0711-5204136
TLX: 7254669

Ghana

Malawi Engineering Co. Ltd.
P.O. Box 2972
D710 A/4 Kojo Thompson Rd.
ACCRA
Fax: 233-667-131
TLX: 2072 MALACO GH

Great Britain

**Philips Scientific Test &
Measurement**
Colonial Way
Watford Herts WD2 4TT
Tel: 0923-240511
Fax: 0923-225067
TLX: 934583 phitmd

**Philips Scientific Test &
Measurement**

Yorkstreet
Cambridge CB1 2PX
Tel: 0223-358866
Fax: 0223-321764
TLX: 817331 phsc cam g

Greece

Philips S.A. Hellénique
PO Box 3153
15, 25th March Street
15 GR 17778 Tavros/Athens
Tel: 30-1-4894911
Fax: 30-1-4815180
TLX: 241566 PHAT GR

Guyana

Guyana Stores Ltd.
19, Water Street
GEORGETOWN
TLX: 2212 GUYSTORE GY

Hong Kong

Philips Hong Kong Ltd.

(For Philips products)
Site 7 ground floor, Whampoa
Garden
Hung Hom, Kowloon,
HongKong
Tel: 7735588
Fax: 852 3345555496
TLX: 43752 PHILH HX

Schmidt & Co (H.K.), Ltd.

(For Fluke products)
18th Floor, Great Eagle Centre
23 Harbour Road
Wanchai, Hong Kong
Tel: (852) (5) 8330-222
Fax: (852) 5-836-2652
TLX: (780) 74766 or 76762
SCHMC HX

Hungary

MTA-MMSZ Philips Service*

Szakasits Arpad u. 59-61
P.O. Box 58
1502 BUDAPEST
Tel: 36-1-1869760
Fax: 36-1-1611021
TLX: 225114 MTAMM H

Iceland*

Heimelistaeki S.F.

(For Philips products)
Saetun 8
125 Reykjavik
Tel: 354-1-691500
Fax: 354-1-691555

Sameind H.F.

(For Fluke products)
Brautarholt 8
125 Reykjavik
Tel: 354-1-25833
Fax: 354-1-621531
TLX: 3136 samein is

India

Peico Electronics &

Electricals Ltd.

I&E Division
(For Philips products)
Band Box House
254 Dr. Annie Besant Road
Bombay 400 025
Tel: 022 4930311/4930590
Fax: 022-4941698
TLX: 76049

Peico Electronics &

Electricals Ltd.

I&E Division
(For Philips products)
7 Justice Chandra
Madhab Road
Calcutta 700 020
Tel: 473621

Peico Electronics & Electri-

cals Ltd.

I&E Division
(For Philips products)
68, Shivaji Marg
New Delhi 110 015
Tel: 530153
Tel: 533956/57*
TLX: 031 3142

Peico Electronics &

Electricals Ltd.

I&E Division
(For Philips products)
No 3 Haddows Road
Madras 600 006
Tel: 472341
TLX: 041 499

Peico Electronics &

Electricals Ltd.

I&E Division
(For Philips products)
7311 St Mark's Road
Bangalore 560 001
Tel: 579119/579164
TLX: 0845-8185

* Service Center.

Hinditron Services Pvt., Ltd.

(For Fluke products)
Industry House
23-B Mahal industrial Estate
Mahakali Caves Road
Andheri (E) Bombay
400 093, India
Tel: (91) (22) 636-4560
(91) (22) 634-8268
Fax: (91) 22-822-0197
TLX: (953) 11-79286 HIPL IN

Indonesia

P.T Daeng Brothers

(For Philips products)
Philips House
Jl. H.R. Rasuna Said Kav. 3-4
Jakarta 12950
Tel: 021 5201122
TLX: 62789 phdc ia

P.T. Lamda Triguna

(For Fluke products)
PO Box 6/JATJG, Jakarta
13001
Indonesia
Tel: (62) (21) 819-5365
Fax: (62) 21-819-9631
TLX: (796) 63938 KA IA

Iran

Philips Iran Ltd.

Private Joint Stock Comp.
PO Box 11365-3891
TEHRAN
Tel: 98-21-674138/675158
TLX: 212545 phps ir

Iraq

Al-Tel Co. Ltd.

P.O.B. 5904
Baghdad
Tel: 964-1-7191982
Fax: 964-1-7191982
TLX: 213899 SAKO IK

Ireland

Circuit Specialists Ltd.

Unit 5, Enterprise Centre,
Plassey Technology Park
Castleroy, Limerick
Tel: 061 330333

Italy

Philips S.p.A.

Sezione S & I, T & M Dept.

Viale Elvezia 2
20052 Monza
Tel: (039) 3635240/8/9
Fax: 039-3635309
TLX: 333343

Japan

NF Circuit Design

Block Co., Ltd.

(For Philips products)
3-20 Tsunashima Higashi, 6
Chome,
Kokokoku, Yokohama 223
Tel: (045) 452-0411
TLX: 3823-297

Nihon Philips Corporation*

Shuwa Shinagawa Building
26/38 Tahanawa 3-Chrome
Minatu-ku Tohyo 108
Tel: 4485511

John Fluke Mfg. Co., Inc.

Japan Branch
(For Fluke products)
Sumitomo Higashi
ShinbashiBldg.
1-1-11 Hamamatsucho
Minato-ku, Tokyo 105, Japan
Tel: (81) (3) 434-0181
Fax: (81) 3-434-0170
TLX: (781) 2424331 FLUKJJP

Jordan

Jordan Medical Supplies & Services

PO Box 140415
Al Biader
Amman Jordan
Tel: 962-6-819929
Fax: 962-2-823556
TLX: 22161 jms jo

Kenya

Philips Kenya Ltd.

Oi Kalou Road, Industrial Area
PO Box 30554
Nairobi
Tel: 254-2-557999
Fax: 254-2-543135
TLX: 24033 PHLP KE

* Service Center.

Korea, Republic of
Myoung Corporation
(For Fluke products)
Yeo Eui Do
PO Box 14
Seoul Korea
Tel: (82) (2) 784-9942
Fax: (82) 2-784-2387
TLX: MYOUNG K24283

Kuwait
Yusaf A. Alghanim & Sons
P.O. Box 223
KUWAIT
Tel: 965-4843988
Fax: 965-4847244

South Korea
Philips Industries (Korea) Ltd.
(For Philips products)
CPO Box 3680, Philips House
260-199, Itaewon-Dong
Yongsan-Ku
Seoul
Tel: 82-2-7970378
Fax: 82-2-7978048
TLX: philkor k 27291

Hanmac Electronics Co. Ltd.
Mijin Bld. 116-2 Samsung-Dong
Kangnam-Ku
Seoul
Korea
Tel: 82-2-5537441
Fax: 82-2-5566816
Tlx: K25749 Hanmaco

Lebanon
Electronic Supplies S.A.R.L.
Autostrade Dora, Hayek Bldg.
PO Box 90 1388
Beirut
Tel: 01-894243
TLX: 42950 DIC1

Luxemburg
Philips Luxembourg
Professional Systems S.A.
Rue des Juncs 4
L-1818 Howald
Tel: 496111
Fax: 400577
TLX: 60572

* Service Center.

Malaysia
Electronic Systems (Malaysia)
Sdn. Bhd.
(For Philips products)
Lot 51 Section 13
Jalan University
Petaling Jaya - Selangor 46200
Tel: 60-3-7560112
Fax: 60-3-7560761

Mecomb Malaysia Sdn. Bhd.
(For Fluke products)
PO Box 24
46700 Petaling Jaya
Selangor, Malaysia
Tel: (60) (3) 774-3422
Fax: (60) 3-774 3414
TLX: (784) MA37764 MECOMB

Malta
Charles A. Micallef & Co. Ltd.
PO Box 527
217 St. Paul str.
Valletta
Tel: 356-221168
Fax: 356-229503

Mexico
Mexicana de Electronica
Industrial S.A. (Mixel)
Diagonal No. 27
Entre Calle de Eugenia Y Ave.
Colonia del Valle
C.P. 03100, Mexico
Tel: (90) (5) 680-4323
Fax: (525) 687-8695
TLX: (383) 177 1823 MDEIME

Mixel Servicios en
Computacion*
Instrumentation Y Perifericos
Blvd. Adolfo Lopez Mateos No.
163
Col. Mixcoac
Mexico D.F.
Tel: 90-5-563-5411

Morocco
Samtel*
2 Rue de Bapaume
Casablanca
Tel: 243050

Somaciel
304 Boulevard Mohammed V
Casablanca 05
Tel: 308051/52
TLX: 27021

Mozambique
Interelectra E.E.
P.O. Box 1159
MAPUTO
TLX: 6203 NEGONHO

Nepal
Bhajuratna Engineering & Sales (P) Ltd.
(For Philips products)
Jyoti Bhawan
PO Box 133 Kantipath
Kathmandu
Tel: 2-25134
TLX: 2264 NPLKAPH

Associated Enterprises
(For Fluke products)
GPO Box 790, Pyaphal Tole
Kathmandu, Nepal
Tel: 13868
TLX: (947) 2588 ASCENT NP

Netherlands
Philips Nederland B.V.
Test en Meetapparaten
Hoevenseweg 55A
Postbus 115
5000 AC Tilburg
Tel: 013-390112
Fax: 013-427528
TLX: 52683

Philips Nederland
Technische Service Prof. Akt.*
Hurksestraat 2C
Gebouw HBR
5652 AJ Eindhoven
Tel: 040-723293
Fax: 040-723337
TLX: 59279 milapnl

* Service Center.

New Zealand
Philips Scientific & Industrial PTY Ltd.
Test & Measurement Dept.
2 Wagner Place
PO Box 4021
Auckland 3
Tel: 09-084-160
Fax: 09-862728
TLX: N2 2395

Nigeria
Associated Electronic Products (Nigeria) Ltd.
KM 16, Ikorodu Road
Ojota
PO Box 1921
Lagos
Tel: 234-1-900160/69
Fax: 234-1-615601

Norway
Norsk A/S Philips Dept. I & E Test & Measurement
Sandstuveien 70
PO Box 1 Manglerud
0612 Oslo 6
Tel: 47-2-741010
Tel: 47-2-290942
Fax: 47-2-381457
TLX: 856-72640

Oman
Messrs. Mustafa Jawad
Trading Co.
PO Box 4918
RUWI - MUSKAT
Tel: 968-709955
Fax: 968-797277

Pakistan
Philips Electrical Co. of Pakistan
(Private) Ltd.
(For Philips products)
Philips Markaz, M.A. Jinnah Road
PO Box 7101
Karachi - 74400
Tel: 92-21-725772-8
Fax: 92-21-726694
TLX: 2874 PHPAK PH

**International Operations
(PAK Private), Ltd.**

(For Fluke products)
505 Muhammadi House
I.I. Chundrigar Road
PO Box 5323
Karachi 2, Pakistan
Tel: (92) (21) 221127
Fax: (92) 21-2411241
TLX: (952) 24494 PIO PK

Paraguay

Philips del Paraguay S.A.

(For Philips products)
Avenida Artigas 1519
Casilla de Correo 605
Asuncion
Tel: 595-21-291924
Fax: 595-21-211662
TLX: py 215

Peru

Philips Peruana S.A.

Carretera Central KM 6.5
Apartado 1841
Lima 1000
Tel: 51-14-350059
Fax: 51-14-423107

**Importaciones y Representaciones
Electronicas S.A.**

(For Fluke products)
Avda. Franklin D. Roosevelt 105
Lima 1, Peru
Tel: (51) (14) 28-8650
TLX: (394) 25663 PE IREING

Philippines

Philips Industrial Development Inc.

(For Philips products)
106 Valero Street
Salcedo Village
Makati, Metro Manila
Philippines
Tel: 810-0161
Fax: 817-3474

**Spark Radio & Electronics,
Corp.**

(For Fluke products)
PO Box 610, Greenhills
Metro Manila 1502
Philippines
Tel: (63) (2) 775192
Fax: (63) (2) 7220313
TLX: (712) 4005 RLA PH PU

Poland

Electronic Instrument Service*

(Philips Service)
Ul. Malechowska 6
60-188 PODZANAN
Tel: 48-61-481998
TLX: 0413791 PHIL PL

Portugal

**Philips Portuguesa, S.A.R.L.
Division of I & E**

Test & Measurement
Av. Eng. Duarte Pacheco 6
1009 Lisboa Codex
Tel: 1-657181
Fax: 1-658013

**Philips Portuguesa*
Division I & E**

Rua Eng Erequi de Campos
182
4100 Porto
Tel: (2) 678278
TLX: 28790

Qatar

Darwish Trading Company

PO Box 92
Doha, Qatar
Tel: 974-434308
Fax: 974-426378

Romania

Polytechnic Inst. Bucarest*

L.C.M.S. Philips Service
P.O. Box 1/285
Str. Polizu 1
BUCAREST 70100
Tel: 40-0-505935
Fax: 167540 via limpex
TLX: 119488 CBTX R

* Service Center.

Saudi Arabia

Messrs. A. Rajab & A. Silsilah
Head Office
PO Box 203
Jeddah 21411
Tel: 966-2-6610006
Fax: 966-2-6610164
TLX: 601180 arndas sj

Messrs. A. Rajab & A. Silsilah
PO Box 260
Riyadh 11411
Tel: 966-1-4122425
Fax: 966-1-4122366
TLX: 404787 arndas sj

Messrs. A. Rajab & A. Silsilah
PO Box 587
Dammam
Tel: 966-3-8322596/8331870
Fax: 966-3-8271962
TLX: 601044 arndas sj

Singapore

Philips Project Development (S) PTY Ltd.
(For Philips products)
Lorong 1, Toa Payoh
Singapore 1231, PO Box 340
Toa Payoh Central Post Office
Singapore 9131
Tel: 65-3502000
Fax: 65-2535873
TLX: philips rs/21375

Rank O'Connor's Pte Ltd.
(For Fluke products)
O'Connor House
98 Pasir Panjang Road
Singapore 0511
Republic of Singapore
Tel: (65) 473-7944
Fax: (65) 472-4508
TLX: (766) RS 21023 OCONSIN

South Africa

South African Philips PTY Ltd.
I & E Division Test & Measurement
10 Bondstreet, Randburg
Johannesburg 2000
Tel: 27-11-889-3911
Fax: 27-11-889-3098/889 3191
TLX: 4-26152-sa

South African Philips PTY Ltd.*
I & E Customer Support Centre
195 Mai Road, PO Box 58088
Martindale, New Ville 2092
Tel: 27-11-470-5937
Fax: 27-11-470-5166
TLX: 4-26152 SA

Spain

Philips Iberica SAE
Depto Instrumentacion de Medida
Poligono Industrial Zona Franca
Sector C-calle F
08004 Barcelona
Tel: 34-3-3361061
Fax: 34-3-3355838
TLX: 51293/59292

Philips Iberica*
Depto Instrumentacion de Medida
Martinez Villergas 2
28027 Madrid
Tel: 34-1-4042200
Fax: 34-1-4048603
TLX: 27710

Philips Iberica SAE*
Jose Olabarria 6
48012 Bilbao
Tel: 34-4-4313800
Fax: 34-4-432 0961
TLX: 31230

* Service Center.

Sri Lanka
Hayleys Electronics & Engineering Ltd.
400, Deans Road
P.O. Box 70
COLOMBO 10
Tel: 94-1-699087
Fax: 94-1-699299
TLX: 23059 SRLCOHA

Computerlink Data Systems, Ltd.
(For Fluke products)
68 Havelock Rd.
Colombo, 5, Sri Lanka
Tel: (94) (1) 502202/3
Fax: (94) 1-502203
TLX: (954) 22455 COLINK CE

Surinam
C. Kersten & Co. N.V.
P.O. Box 1808
PARIMARIBO

Surtel
P.O. Box 155
PARIMARIBO
Tel: 597-72118/77880
Fax: 597-52745
TLX: 162 SN

Sweden
Philips Kistaindustrier AB
Test & Measurement
PO Box 33
16493 Kista
Tel: 46-8-7031370
Fax: 46-8-7520743
TLX: 17173 philkis

Switzerland
Philips AG Test und Messtechnik
Postfach 670
8027 Zurich
Tel: 01 4882390
Fax: 01 4828595
TLX: 815780-0

Philips SA
Test et Mesure
Avenue du Mont Blanc
1196 Gland
Tel: 022/647171

Syria
Al-Shahed Electronics and Trading Co.
Fardoss Street 79
Kassas and Sadat Building
P.O. Box 2442
Damascus
Tel: 228003/218605
TLX: 411203 phisyrr

Taiwan
Philips Taiwan Ltd.
(For Philips products)
581, Min Sheng East Road
10446 Taipei
Taiwan
Tel: 886-2-5097666
Fax: 886-2-5005899

Schmidt Scientific
5/F, 344 Min Sheng E. Rd.,
Taipei
Taiwan
Tel: 02-5005779
Fax: 886-2-5029692
TLX: 11111 Schmidt

Tanzania
Philips (Tanzania) Ltd.
Nkrumah Street
Dar es Salaam
Tel: 2555129571
TLX: 41016

Thailand
Philips Electrical Co. of Thailand Ltd.
(For Philips products)
283, Silom Road
PO Box 961
Bangkok 10500
Tel: 66-2-233-6330/9
TLX: 87327 philtha th

* Service Center.

Measuretronix Ltd.
(For Fluke products)
210231 Ramkamhaeng Road
Bangkok 10240
Thailand
Tel: (66) (2) 375-2733
Fax: (66) 2-374-9965
TLX: (788) 82796 HUAMARK
TH

**Trinidad / West Indies
Compression & Power Services (1988) Ltd.**
P.O. Box 76
SAN FERNANDO By Pass
Tel: 653-5445/6/7
Fax: 1.809.657.0353
TLX: 32451 WG

**Tunisia
S.T.I.E.T.**
32 bis rue Ben Ghedahem
Tunis
Tel: 348666
TLX: 14512

**Turkey
Türk Philips Ticaret A.S.**
Talatpasa Caddesi no. 5
PO Box 161
80640 Levent-Istanbul
Tel: 90-1-1792770
Fax: 90-1-1693094
TLX: 24192 phtr tr

**United Arab Emirates
Al Sanani Trading Est.**
PO Box 7187
Abu Dhabi, U.A.E.
Tel: 971-2-771370
Fax: 971-2-728963
TLX: 23966 Sanani em

Haris Al-Afaq Ltd.
PO Box 8141
Dubai, U.A.E.
Tel: 971-4-283625
Fax: 971-4-281285

* Service Center.

**Uruguay
Industrias Philips del Uruguay
S.A.**
(For Philips products)
Avenida Uruguay 1287
Casilla de Correo 294
Montevideo, Uruguay
Tel: (598) (2) 921111
Fax: (598) (2) 920601

**U.S.S.R.
N.V. Philips Gloeilampen-
fabrieken**
Mytnaya Str.1
Fl. 7, Office 18
MOSCOW
Tel: 7095-2302485
Fax: 7095-2302485
TLX: 413961 PHIL SU

Infomedia Sotrudnichestvo
Kievskaya, 2 - Office 106
121111 MOSCOW
Tel: 240 52 52
Fax: 230 28 18
TLX: 411670 DNEPR SU

**Venezuela
Inds. Venezolanas Philips
S.A.**
(For Philips products)
Apartado Aereo 1167
Caracas 1010-A
Tel: 58-2-905.7061
Fax: 58-2-951.7339
TLX: 25267 ivpsa vc

Cossin C.A.
(For Fluke products)
Calle 9 Con Calle 4, Edifl
Edinurbi
Apartado de Correos NR-70.136
Los Ruices
Caracas 1070-A, Venezuela
Tel: (58) (2) 241-03-09
TLX: (395) 21027EMVEN VC

**Yemen
Rashed Trading & Travel
Agency**
Ali Abdilmugni st.
PO Box 1221
Sana'a, Yemen
Tel: 967-2-273231
TLX: 2230 abgbar ye

Yugoslavia
N.V. Philips Gloeilampenfabrieken
Strahinjica Bana 47/II
Postanksi fah 484
BEOGRAD
Tel: 38-11-625344
Fax: 38-11-635777
TLX: 12499 YU PHILIPS

Jugoelectro*
Jurija Gagarina 81
Block 70
11070 BEOGRAD
Tel: 38-11-178134
Fax: 38-11-175472
TLX: 12370 YUJUELB

Technicar Servis*
(For Fluke products)
Jurisiceva 25
41000 ZAGREB
Tel: 041-276333
Fax: 041-274416

Zaire
Philips Electronics S.A.R.L.
137 Boulevard du 30 Juin
BP 16636
Kinshasa
Tel: 31693
TLX: 21078 kinshasa

Zambia
Philips Electrical Zambia Ltd.
Mwembeshi Road
PO Box 31878
Lusaka
Tel: 218511/218701
TLX: za 41220

Zimbabwe
Philips Electrical (Pvt.) Ltd.
62 Mutare Road
PO Box 994
Harare
Tel: 263-4-47211
Fax: 263-4-47966
TLX: 2236 ZW

For Countries not listed above:

**Philips Export B.V.
I & E Export
Test & Measurement**
building HVW-3
PO Box 218
5600 MD Eindhoven
The Netherlands
Tel: +31 40 766546
Fax: +31 40 766612
TLX 35000 phtc nl

Fluke Int'l Corp.
PO Box 9090
Mail Stop 206A
Everett, WA 98206-9090
Tel: 206-356-5500
Fax: (206) 356-5116
TLX: 185103 FLUKE UT

U.S.A.

Alabama
Huntsville
4920 Corporate Drive Suite J
Huntsville, AL 35805-6202
(205) 837-0581

Arizona
Phoenix
2211 S. 48th Street Suite B
Tempe, AZ 85282
(602) 438-8314

* Service Center.

California

Irvine*
PO Box 19676
Irvine, CA 92714
(714) 863-9031

Nothorn*
46610 Landing Parkway
Fremont, CA 94538
(415) 651-5112

Colorado

Denver*
14180 E. Evans Ave.
Aurora, CO 80014
(303) 695-1000

Connecticut

Hartford
Glen Lochen East
41-C New London Turnpike
Glastonbury, CT 06033
(203) 659-3541

Florida

Altamonte Springs*
550 South Northlake Blvd.
Altamonte Springs,
FL 32803
(407) 331-4881

Georgia

Atlanta
2700 Delk Road Suite 150
Marietta, GA 30067
(404) 953-4747

Illinois

Chicago*
1150 W. Euclid Avenue
Palatine, IL 60067
(708) 705-0500

Indiana

Indianapolis
8777 Purdue Road Suite 101
Indianapolis, IN 46268
(317) 875-7870

Massachusetts

Boston
900 Middlesex Technology
Center
Building 8
Billerica, MA 01821
(508) 663-2400

Maryland

Rockville*
5640 Fishers Lane
Rockville, MD 20852
(301) 770-1570

Michigan

Detroit
45550 Helm Street
Plymouth, MI 48170
(313) 522-9140

Minnesota

Minneapolis
1380 Corporate Center Curve
Suite 113
Eagan, MN 55121
(612) 854-5526

Missouri

St. Louis
11756 Borman Drive Suite 160
St. Louis, MO 63146
(314) 993-3805

New Jersey

Paramus*
PO Box 930
Paramus, NJ 07652
(201) 262-9550

New York

Rochester
4515 Culver Road
Rochester, NY 14622
~~(716) 353-1400~~

716-353-1400

North Carolina

Greensboro
1310 Beaman Place
Greensboro, NC 27408
(919) 273-1918

* Service Center.

Ohio

Cleveland

Plaza South Three Suite 402
7271 Engle Road
Middleburg Heights, OH 44130
(216) 234-4540

Pennsylvania

Philadelphia

200 Lindenwood Drive
Malvern, PA 19355
(215) 647-9550

Texas

Dallas*

1801 Royal Lane Suite 307
Dallas, TX 75229
(214) 869-0311

San Antonio

10417 Gulfdale
San Antonio, TX 78216
(512) 340-0498

Washington

Seattle*

2375 130th Ave. N.E.
Suite 100
Bellevue, WA 98005
(206) 881-6966

* Service Center.

Chapter 12

Utilities

Utility Disk 12-2
Setting the Date and Time 12-3
Formatting Disks 12-4
Copying Disks 12-4

Utility Disk

The utilities described in this chapter can be found on the Utility disk delivered with your instrument. In order to access a utility, you should boot the instrument from the Utility disk, instead of from the System disk.

After the instrument has started up, you see a menu on the screen from which you can select a utility. Go to the field of the utility you require, and press the *SELECT* key. A popup menu then appears which guides you through the use of the utility. (See "Setting the Date and Time" below as an example.)

Setting the Date and Time

A facility is available on the Utility disk to enable you to set the date and time, and the format of presentation, on the instrument.

After the procedure has been verified the date and time are stored in the RAM of the instrument and protected by the battery backup, therefore this procedure is not required every time the instrument is powered on.

The date and time can be set using the following procedure:

- Select the "Set date and time" utility from the utilities menu. The "Set date and time" popup menu appears.
- Move to the check field defining the time format required and press the *SELECT* key.
- Move to either the *Date* or *Time* field. These are normal editable fields (see Chapter 3, "Menu Overview": "Field Types"). Each part of the date and time (day, month, year, hour and minutes) must consist of two digits, so include leading zeros. The parts are separated by dots. The hours should always be entered in 24-hour format. You will not be able to leave a field if the entries you make in it are not valid.
- Exit this popup menu by selecting either the *return* or *cancel* field. If the *return* field is selected, the instrument will use the new date and time.

Formatting Disks

With the format utility you can initialize new floppy disks.

The format utility can be selected from the utilities menu as described in the introductory section of this chapter.

After you have selected the format utility, you are prompted to insert the disk you want formatted.

Note: Formatting a disk which already has data on it will destroy all that data.

Copying Disks

The copy disk utility allows you to copy the files contained on one disk (the source) to another disk (the destination).

The copy disk utility can be selected from the utilities menu as described in the introductory section of this chapter.

After you have selected the copy disk utility you are prompted if you want to format during copying or not. If you wish to copy to an unformatted (*i.e.*, completely new) disk, then select the "Format + copy" option. If the disk has already been formatted, use the "copy" option.

Note: Formatting a disk which already has data on it will destroy all that data.

While copying, you are prompted to insert the source and destination disks as appropriate.

Note: Copy disk will not copy between different format disks (*i.e.*, from 720 Kb to 1.44 Mb or vice versa). You will be informed if there is an error of this kind.

Microprocessor Support

Insert the documentation delivered with the Microprocessor support options in this section.

Microprocessor Support

PM 3580/PM 3585 User Manual

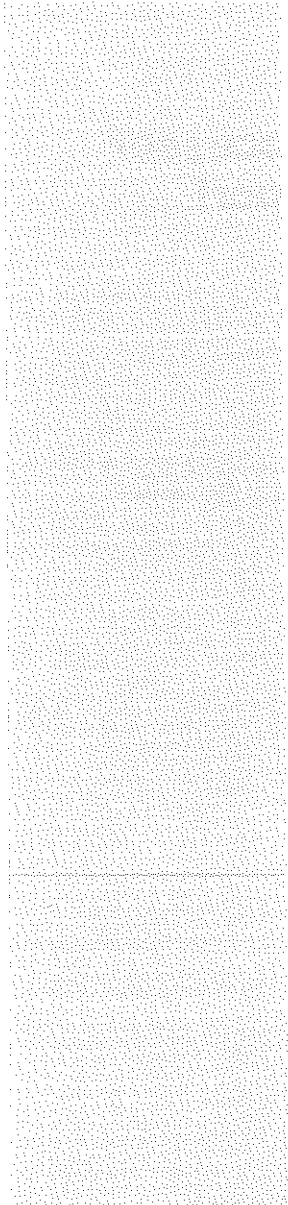

PROBLEM REPORTING / CHANGE REQUESTS

This PHILIPS instrument has been designed and manufactured to the highest quality standards to give you many years of trouble-free and accurate measurements.

However, if malfunctions are detected during the correct operational use of the instrument you are invited to report these problems to your local Fluke/Philips representative by means of the "PROBLEM REPORT / CHANGE REQUEST", reply cards included.

If you have any further suggestions about how this product could be improved, please contact your local Fluke/Philips representative.

Fluke/Philips addresses are listed in chapter 11 of this User Manual

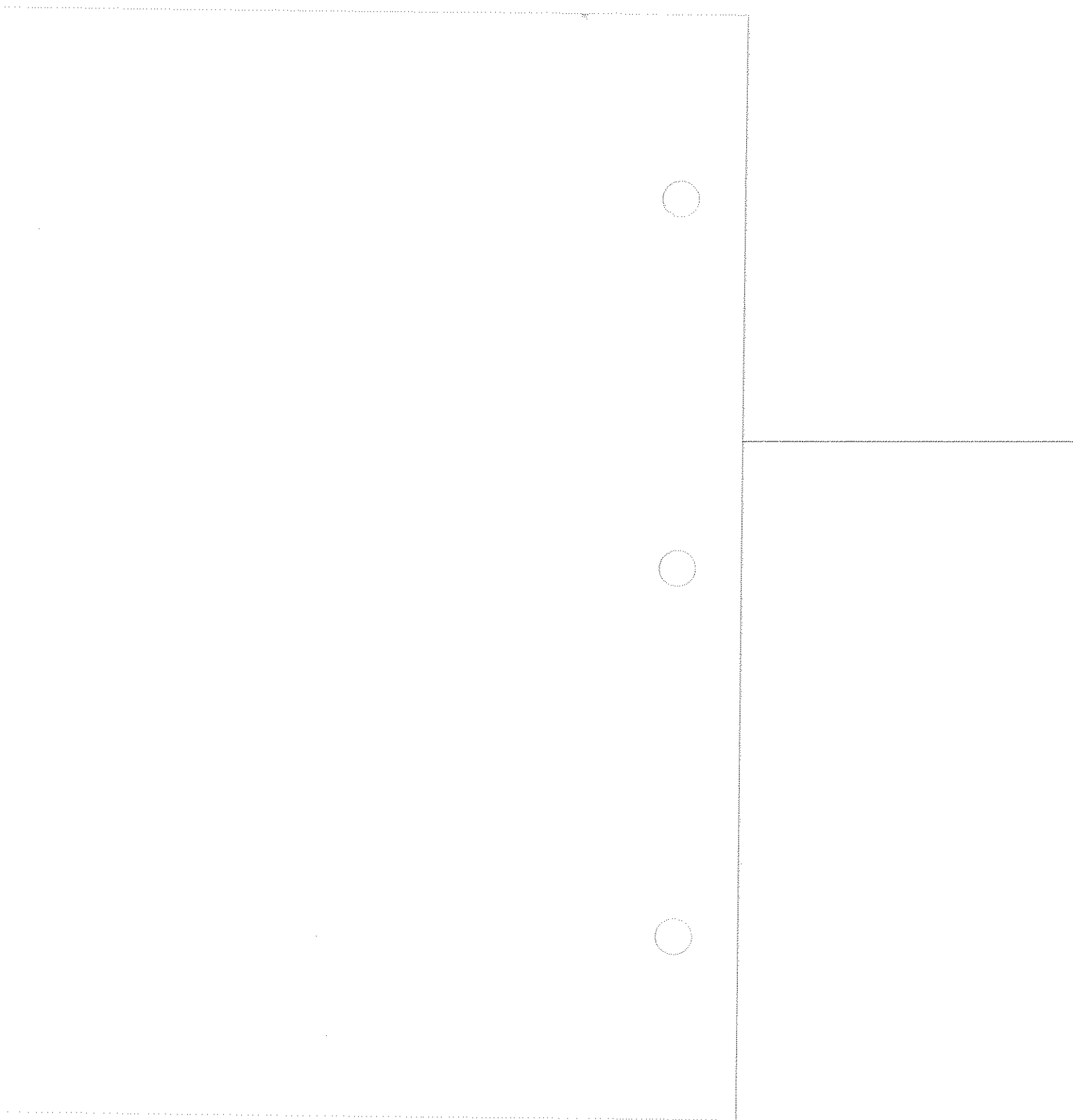

A

- abort printing 3-24
- absolute cursor movement 6-12
- absolute long pointer addresses 7-5
- accessories 1-10, 11-2
- accessory pouch 11-2
- accumulate mode 6-27
- action fields 3-5
- activating the disassembler 7-10
- active adapters 8-8
- active window 6-35
- activity indicators 3-2
- activity on the pods 3-7
- adapter types 8-7
- adapters 7-2
- add labels to display 6-17
- address lines 4-15
- addresses for Fluke/Philips 11-11
- addresses, target 7-5
- adjustment safety instructions 11-5
- after condition 5-23, 5-25
- analyzer activity indicators 3-2
- analyzer name field 3-3, 6-5
- analyzing the data 6-1-6-36
- architecture of Dual Analysis Per Pin 1-3
- arrow keys 2-4, 3-8
 - trace menu 3-14
- Ascii label 6-30, 6-32
- assigned channels 4-8, 7-3, 6-26, 6-30
- assigned clocks 7-3
- assigned labels 7-3
- assigned pods 3-4, 3-8, 4-9, 7-3
- assigning
 - clocks 8-8
 - labels 8-8
 - pods 3-6
 - qualifiers 4-8
 - thresholds 3-12
- At Y field 7-9
- attribute field 3-9, 4-9, 4-12
- attributes
 - clock 3-9, 4-12
 - label 3-9, 4-9, 5-18
 - set by disassembler 7-3
 - timing label 3-9, 4-11, 5-19, 6-16
- auto in data stored field 5-4
- auto-load 1-6, 3-7, 3-22
- automatic self-test 1-10, 11-9
- automatic synchronization 7-9
- auto-repeat 1-6, 3-3, 3-15, 3-16, 5-39

B

- backspace key 2-6
- base field 5-20, 6-32
- base of label 6-32
- basic measurement loop 1-5
- blank columns 6-30
- blinking activity indicator 3-2
- BNC connectors 2-7, 3-16
 - triggering 5-24
- boxes on display 3-3, 3-4, 6-14
- brightness control 2-8, 11-9
- bus field 6-23
- bus signals 6-23

PM 3580/PM 3585 User Manual

bus transfers 7-6
busses, multiplexed 4-14, 4-15, 5-11

C

cables to pods 8-3
calibration procedure 11-9
cancel printing 3-24
caution 8-2, 11-3
center of display 3-19, 6-12
Centronics connector 2-7, 9-3
change labels on display 6-17
channel as clock 4-2
channel width 2-2
characters for cursor movement 6-13
chassis connection 8-2
check fields 3-5
choosing fields 3-3
clip versions of adapters 8-7
clips for measuring 8-5, 11-2
clock attributes 3-9
 disassembler and 7-3
clock attributes menu 3-9, 4-12
clock external 6-6
clock internal 6-6
clock qualifiers 3-8, 4-3, 4-5, 4-8
clocks 3-8, 4-1-4-18
 multiple 4-6
 state patterns 5-15
 validity for label 4-9
 validity for range 5-12
color-coded stickers 8-4
combinations of pattern recognizers 5-16
common sequencer 1-3
communication interfaces 2-7, 9-4, 9-5
comparator 3-11
compare data 6-7
 dial mode 6-20
compare new and reference 6-7
condition, level 5-23
CONFIG key 3-6
configuration menu 3-6, 7-3, 6-4
configure instrument with disassembler 7-3
configuring analyzer 8-8
connecting leads to signals 8-5
connector to pods 8-3
connectors 2-7, 9-1-9-7
 impedance 8-3
control keys 2-4
copy disks 12-4
copy files 3-22, 12-4
copying to reference memory 6-7
correlate data capture 6-9
corrupted state mnemonic 7-6
Coscroll 6-37
coscroll 6-35, 6-36
cover 11-2
creating a level 5-24
creating split screen 6-34
current date and time 3-2, 12-3
current field 3-3
current status indicator 3-2
cursor keys *see arrow keys*
cursor movement 6-19, 6-29
cursor position fields 6-10, 6-11

cursor position units 6-13
cursors 3-19, 6-12

D
D connectors 2-7, 9-1
DAPP *see Dual Analysis Per Pin*
data
 analysis 6-1-6-36
 busses 4-14
 capture time 6-9
 comparison 5-40, 6-7
 copy to reference memory 6-7
 coscroll 6-36
 display 6-1-6-36
 finding 6-30
 overview 6-8
 position in 6-12
 reference 6-7
 representation 7-5, 6-26, 6-30
 sampling 4-2
 scrolling 6-12
 scrolling through 6-11
 searching 6-30
 source 6-4
 storage, post-trigger 5-6
 stored at level 5-25
 stored type 5-4
 synchronous display 6-36
 transfers 7-9
 viewing 6-12
data comparison field 5-40
data source field 6-5
data stored field 5-4
date display 3-2
date setting 12-3
deactivating the disassembler 7-10
decimal label 6-32
default
 display on same line as 4-14
 qualifier(s) 4-14
 set up 1-6
 timing label 4-11, 4-14
 valid for clock 4-11
delete files 3-22
delete key 2-4
delete labels from display 6-16
deleting window 6-35
detachable leads 8-4
dial 2-3-2-5
 locking 6-11
 movement 6-12
 operation 6-11
 scrolling 3-19, 6-12
 time scale 6-22
dial field 6-29
dial mode
 find 6-30
 state display 6-29
 waveform display 6-19
dial mode field 6-11
differences in time 6-15
different dial mode 6-20, 6-29
DIP packages 8-7
DIS file 8-8

PM 3580/PM 3585 User Manual

disa field 7-10, 6-33
disassembler
 bus transfers 7-6
 choice 3-6
 file 8-8
 setup 7-3
 software 7-2
disassembler parameters 7-6
disassembler parameters menu 7-6, 7-9, 6-33
disassemblers 7-1-7-10, 6-33, 8-8
disassembly 7-2, 6-33
disk copy 12-4
disk drive 3-22, 9-2
disk facilities 1-6
display concepts 6-2
display definition area 6-2
display disassembler parameters 7-7
display height of waveform 6-22
DISPLAY key 3-18
display labels 6-16
display locator 6-2, 6-14
display menu 3-18, 4-10, 5-40, 7-3, 7-10, 6-2-??
display on same line field 4-12
display options 7-7
display screen 2-2
display sequencer levels 6-17
display special functions menu *see special functions popup menu*
display split screen 6-34
display type field 3-21
displayed value 6-26
division dial mode 6-19
divisions
 time scale 6-22
divisions of display 6-21
documentation 1-7
Dual Analysis Per Pin 1-2, 1-3, 7-2, 8-8
dual window display 6-34
duration of pattern 5-7

E

earthing 11-6
earthing leads 8-4
ECL threshold 3-11
edge 5-36
edge detector 5-9
edge dial mode 6-19
editable fields 3-4
ending repetitive measurements 5-39
equal dial mode 6-20, 6-29
example
 clocks 4-2
 display beyond data 6-14
 immediate sequence 5-32, 5-33
 immediate state words 5-11
 interrupt response time 5-28
 maximum pulse width 5-29
 minimum pulse width 5-29
 multiple clocks 4-6
 multiplexed busses 4-14, 5-11
 pattern sequence 5-31
 program flow 5-26
 pulse duration 5-30
 qualifiers 4-3, 4-5
 separately trigger state and timing 5-34

PM 3580/PM 3585 User Manual

sequencer 5-26
trigger words area 5-19
wait for a pattern sequence 5-31
exchange labels on display 6-17
executed instructions 7-7
exploring the instrument 2-2
extension sockets 8-7
external clocks (*see also clocks*) 1-4, 6-6
external connectors 2-7, 9-1-9-7
external monitor connector 2-8, 9-6
external output 3-16

F

falling edge detection 5-9
fetched instructions 7-7
field types 3-4
file handling 3-22
files
 copying 12-4
 formats 10-1-10-3
 reference data 6-7
find dial mode 6-29, 6-30
first character select fields 3-5
flashing activity indicator 3-2
floppy disk 3-22, 11-2
floppy disk drive 9-2
Fluke addresses 11-11
format disks 3-22, 12-4
format menu 3-8, 5-18, 7-3, 6-16, 8-8
 clocks 4-2
 labels and polarity 6-2
format of files 10-1-10-3
French manuals 11-2
front cover 11-2
front ends 8-2
 standard 8-4
front panel 2-2
function fields 3-5
fuse 2-8

G

German manuals 11-2
Getting started guide 1-7, 11-2
glitch data 3-16, 5-36
glitch detector 5-8
glitch dial mode 6-20
go to level 5-24
grabbers 8-5
graph mode 6-24
graphic display 6-24
ground leads 8-4
grounding 11-6
grounding symbol 11-4

H

halt printing 3-24
hardcopy file format 10-2
hardcopy to disk field 3-24
hexadecimal label 6-32
high voltage symbol 11-4
highlighted comparisons 6-7
highlighted field 3-3
hollow rectangle 6-14
home key 2-4

PM 3580/PM 3585 User Manual

horizontal dimension 6-21
horizontally split screen 6-34

I
I/O activity 7-9
I/O key 3-22
I/O menu 1-6, 3-22, 6-7, 8-8
IEEE connector 2-7, 9-4
If condition 5-24
immediate operands 7-5
immediate sequence example 5-32, 5-33
immediate state words 5-11
impaired safety protection 11-4
impedance of probes 8-3
inactive analyzer indicator 3-2
indicator repeat mode 3-3
information fields 3-4
initial character select fields 3-5
initial inspection 11-2
initialize disks 3-22, 12-4
INS key 2-6
insert key 2-4, 2-6
insert mode 2-6
inspection, initial 11-2
installation 11-1-11-10
instruction mnemonics 7-5
instruction representation 7-5
instrument overview 2-1-2-8
instrument preparation 1-5
internal clock 6-6
interrupt response time sequence 5-28
ior mnemonic 7-6
iow mnemonic 7-6

K
keyboard 2-2-2-6
keying mechanism 8-5

L
label attributes menu 3-9, 4-9, 4-11
Label Selection 6-17
labels 3-8
 add to display 6-17
 ascii 6-30
 attributes 3-9, 5-18
 attributes and disassembler 7-3
 base of 6-32
 busses 6-23
 change on display 6-17
 data representation 6-26
 delete from display 6-16
 for busses 4-14
 level 6-32
 overlapping 5-21
 scrolling 6-16
 selecting for display 6-16
 time 6-31
 validity for clock 4-9
 values 6-26, 6-27
last user-defined sequence 5-38
leads, detachable 8-4
level
 creating 5-24
 data storage 5-25

dial mode 6-20, 6-29
displaying 6-17
go to 5-24
label 6-32
number 5-23
structure 5-23
level options popup menu 5-25
line dial mode 6-29
line voltage 2-8
 setting 11-7
list display 3-18
list fields 3-5
live part symbol 11-4
load data 3-22
load instrument settings 1-6
loading disassembler 3-6, 7-3
locator on display 6-14
locking dial 6-11
logic pod 11-2
logic target 8-9, 11-2
logical interpretation of signals 3-12

M

mains lead 2-8
mains voltage 2-8
 setting 11-7
maintenance safety instructions 11-5
manual stop 5-40
manual synchronization 7-9
manuals 1-7, 11-2
maximum number of clocks and qualifiers 4-8
maximum pulse width 5-29
measure time differences 6-15
measurement file 6-7
measurement loop 1-5
measuring clips 8-5, 11-2
memory 3-16
 activity 7-9
 contents 6-8
 overview 6-8
 reference 6-7
 trigger point in 3-16
 usage 3-20, 6-8
menu
 clock attributes 3-9, 4-12
 clocks on format 4-2
 configuration 3-6, 7-3, 6-4
 disassembler
 parameters 7-6
 disassembler parameters 7-9
 display 3-18, 4-10, 5-40, 7-3, 7-10, 6-2-??
 fields 3-3
 format 3-8, 5-18, 7-3, 6-16, 8-8
 I/O 3-22, 6-7, 8-8
 label attributes 3-9, 4-9, 4-11
 level options popup 5-25
 menu bar 3-2, 5-41
 overview 3-1-3-24
 popup menu fields 3-5
 predefined sequences 5-35
 print 3-24
 purpose 3-2
 run parameters popup 5-39, 5-40
 set trigger word popup 5-20

PM 3580/PM 3585 User Manual

- special functions 3-20, 5-39, 6-7, 6-8, 6-10, 6-36
- state 3-18, 6-28-6-33
- timing 3-18, 6-18-6-27
- trace 3-14, 5-1-5-41, 6-4
- utilities 12-2-12-4
- waveform 3-18, 6-18-6-26
- menu keys 2-4
- menus 1-5
- microprocessor adapters 7-2, 8-6
 - see also appendices*
 - impedance 8-3
- microprocessor data bus 7-9
 - clocking 4-6
- microprocessor setup, 8085 4-18
- microprocessors
 - clocks 4-6
- minimum pulse width sequence 5-29
- mnemonics of instructions 7-5
- mode
 - accumulate 6-27
- mode of dial 6-11
- monitor connector 2-8, 9-6
- mouse connector 2-7, 9-5
- move measurement data 6-11
- moving between windows 6-35
- moving the highlight 3-3
- mr mnemonic 7-6
- MS-DOS 3-23
- multiple clocks 4-6
- multiplexed busses 4-14, 4-15, 5-11
- mw mnemonic 7-6

N

- name of analyzer field 3-3
- negative polarity 3-13
- new data 3-19, 3-20, 3-22
- new data memory usage 6-8
- new disks 3-22, 12-4
- new/ref field 6-5
- nibble 7-9
- noise on system 3-11
- not in range detector 5-15
- not state words 5-11
- numeric fields 3-4
- numeric keys 2-5

O

- octal label 6-32
- ON/OFF switch 2-8
- opc mnemonic 7-6
- operand field 7-5
- operand values 7-5
- operator safety 11-3
- optional accessories 1-10
- optional connector 2-7, 9-4
- options
 - disassembler 7-7
- or if condition 5-24
- overdrive 3-11
- overlapping labels 5-21
- overview of the instrument 2-1-2-8
- overwrite mode 2-6

P
packages, disassembly 7-2
page dial mode 6-20, 6-29
parameters
 clock 3-9
 disassembler 7-6
 labels 3-9
passive adapters 8-7
pattern duration 5-7
pattern recognition 1-3, 5-7
 specifying 5-17
pattern recognizer combinations 5-16
pattern recognizer fields 5-17
pattern recognizers
 state 5-10
pattern sequence example 5-31
patterns 3-14
pause printing 3-24
PC usage 3-23
percentage of memory filled 5-6
periods of a run 5-5
PF 8600/20 11-2
PF 8600/24 11-2
PF 8666/20 11-2
PF 8669/20 11-2
PF 8690 11-2, 11-9
PGA packages 8-7
Philips addresses 11-11
pin specifications 9-1-9-7
pipeline architecture 7-9
PLCC adapters 8-7
PM 3580 instruments 1-2, 5-9, 11-2
 data from PM 3585 6-4
PM 3585 instruments 1-2, 1-3, 11-2
pod label sheet 11-2
pod system 8-2
pods
 activity indicator 3-7
 assigned 4-9, 7-3
 assigning 3-6
 cables 8-3, 9-7
 connectors 8-3, 9-7
 format menu 3-8
 microprocessor adaptors 7-2
 power lines on 8-3
 range detector 5-12
 scrolling 3-8
 stickers for connectors 8-3
 thresholds 3-8
polarity 3-8, 3-12
popup menu fields 3-5
popup menus *see menus*
position in data 6-12
position of cursor 6-12
position of the trigger point 3-16
position of trigger 3-21, 6-9
post-trigger period 5-6
power cable 2-8, 11-2, 11-9
power lines on pods 8-3
power on 1-10, 11-9, 12-2
power on auto-load 3-22
power on self-test 1-10, 11-9
power switch 2-8
power up 11-9, 12-2

PM 3580/PM 3585 User Manual

predefined cursor positions 6-13
predefined sequences 3-15, 3-16, 5-35–5-38
predefined state sequences 5-37
predefined timing sequences 5-36
predefined value fields 3-4
preparing the instrument 4-5
pre-trigger period 5-5
PRINT key 3-24
print menu 3-24
print screen 3-24
printer connector 2-7, 9-3
printer file format 10-2
probe impedance 8-3
probing 8-1–8-9
program context mode 7-7
program flow sequence 5-26
protective earth symbol 11-4
pulse duration sequence 5-30
purpose of each menu 3-2

Q

qualifier expressions 4-8
qualifier(s) field 4-13
qualifiers 3-8, 4-3, 4-5
question mark value 6-30

R

R cursor 3-19, 6-11, 6-15, 6-19, 6-29
 comparisons 6-7
radix of label 6-32
range detector 5-12–5-15
 consistency 5-15
 not in 5-15
 not specified 5-14
 trigger words area 5-21
RC compensation 8-2, 8-4, 8-7
RC connectors 8-7, 8-9
 impedance 8-3
read cycle 4-15
recognizer fields 5-17
reference comparison 6-7
reference cursors 6-11
 see also R cursor and S cursor
reference data 3-19, 3-20, 3-22, 6-7
 memory usage 6-8
Reference guide 1-7, 11-2
remote operation connector 2-7, 9-4
rename files 3-22
repair safety instructions 11-5
repeat mode timer 3-3, 5-41
repeating runs 1-6, 3-15, 3-16, 5-39, 6-7
repetitive measurements 5-39
replacement safety instructions 11-5
representation of instructions 7-5
reset analyzer 3-7
reset the instrument 3-7
response time of interrupt sequence 5-28
restart field 7-9
restart sequence 3-15, 5-26, 5-36
restore data 3-22
restore last user-defined sequence 5-35
rising edge detection 5-9
R-S field 6-15
RS232 connector 2-7, 9-5

run definition area 3-15
run key 2-4
run mode 3-15, 3-16
run parameters popup menu 5-39, 5-40
run periods 5-5

S

S cursor 3-19, 6-11, 6-15, 6-19, 6-29
 comparisons 6-7
 safety 11-1-11-10
 safety notice 11-4
 sample numbers 6-10
 sampling state data 4-2
 save data 3-22, 6-7
 save reference to disk 6-7
 scale divisions 6-19
 screen image file format 10-2
 screen *see display or menu*
 SCREEN.HC file 3-24
 format 10-2
 scroll dial mode 6-19
 scrolling
 coscroll 6-36
 display 2-4, 3-19, 6-11, 6-19, 6-29
 fields 2-4, 6-16
 labels 5-18, 6-16
 modes 3-19, 6-19, 6-29
 pattern fields 5-18
 pods 3-8
 synchronized 3-20
 waveforms 6-19
 search data 6-30
 select
 analyzer 3-3
 data source 6-4
 disassembler 3-6, 7-3
 display position 6-12
 fields 3-3
 labels for display 6-16
 SELECT key 2-5
 self-test 1-10, 11-9
 separately trigger state and timing example 5-34
 sequence
 break 5-31
 last user-defined 5-38
 pattern 5-7
 patterns 3-14
 restart 3-15, 5-36
 state 5-10
 timing 5-7
 type 3-15
 user-defined 5-7
 sequencer 1-3
 level display 6-17
 sequencer area 3-16
 sequencer facilities 5-22
 sequences
 predefined 5-35-5-38
 serial mouse connector 2-7, 9-5
 service center addresses 11-11
 Service manual 1-7, 11-2
 SET file 8-8
 set reference cursors 6-11
 see also R cursor and S cursor

PM 3580/PM 3585 User Manual

- set trigger word popup menu 5-20
- set up analyzer 8-8
- setting date and time 12-3
- setting files 8-8
- setting mains voltage 11-7
- settings
 - loading 1-6, 7-3, 6-7
 - storing 1-6, 6-7
- setup disassembler 7-3
- show data transfers 7-9
- signal ground 8-2
- signal leads 8-4
- signal logic 3-12
- signals of a bus 6-23
- signed operands 7-5
- simultaneous state and timing per pinsee *Dual Analysis Per Pin*
- single run mode 3-15
- socket versions of adapters 8-7
- software 11-2
- source of data 6-4
- special functions popup menu 3-20, 5-39, 6-7, 6-8, 6-10, 6-36
- specifying patterns for recognition 5-17
- split screen display 3-20, 6-34
- standard accessories 1-10, 11-2
- standard front end 8-4
- starting repetitive measurements 5-39
- state clocks 4-1-4-18
- state clocks *see also clocks* 4-3
- state data 3-16
- state list display 3-18, 6-28-6-33
- state pattern recognizers 5-10, 5-19
- state sequences 5-10
 - predefined 5-37
- state trigger point 5-6
- state words 5-10
 - clocks 5-15
 - immediate 5-11
 - not 5-11
 - not in range 5-15
 - range 5-12
 - specifying 5-17
- step dial mode 6-19
- stickers for pod connectors 8-3
- stop auto-repeat 5-40
- stop condition field 5-40
- time-out condition 5-25
- STOP key 2-4, 5-40
- stop printing 3-24
- storage per label 3-16
- store at level 5-25
- store instrument settings 1-6, 6-7
- stored data 3-16
- storing in reference memory 6-7
- storing only post-trigger data 5-6
- sw_{1,2} 5-10
- switching on 1-10, 11-9
- symbols - safety 11-4
- synchronization field 7-9
- synchronized scrolling 3-20
- synchronous systems 4-6
- system disk 11-9
- system software 11-2

T

- T/div field 6-21
- T₀ 3-21, 6-9
- target addresses 7-5
- terminal earth symbol 11-4
- terminating repetitive measurements 5-39
- threshold detector 3-11
- threshold level 3-11
- time differences 6-15
- time display 3-2
- time interval 6-21
- time label 6-31
- time or sample numbers 6-10
- time origin 3-21, 6-9
- time scale 6-21
- time scale divisions 6-22
- time setting 12-3
- time-out value 5-25
- timer of repeat mode 3-3
- times condition occurs 5-24
- TimeWord 5-7
- timing data 3-16
- timing diagram 4-3
 - 8085 4-15
- timing label attributes 3-9, 4-11, 5-19, 6-16
 - see also label attribute*
- timing pattern duration 5-7
- timing pattern recognizers 5-7, 5-19
- timing sequences 5-7
 - predefined 5-36
- timing trigger point 5-6
- timing waveform display 3-18, 6-18-6-27
- timing words 5-7
 - specifying 5-17
- timing/state field 6-5
- toggle fields 3-4
- trace control 5-1-5-41
- TRACE key 3-14
- trace menu 3-14, 5-1-5-41, 6-4
 - layout 3-14
 - moving on 3-14
 - predefined sequences 5-35-5-38
- transitional timing 1-4
- translate disassembly 7-7
- translate *see also disassembly*
- translation options 7-9
- TRIG IN connector 2-7
- TRIG OUT connector 2-7, 3-16
- trigger position 5-5
- trigger BNC 5-24
- trigger field 5-25
- trigger other analyzer 5-24
- trigger position 3-16, 3-21, 5-5, 6-9
- trigger position field 3-16, 5-6
- trigger separate sections 3-16
- trigger sequence *see sequence*
- trigger state 5-24
- trigger state and timing separately 5-34
- trigger time 6-9
- trigger timing 5-24
- trigger words area 3-17, 5-17, 5-18, 5-19, 5-35
- triggering 3-14, 5-5
- triggering and polarity 3-13
- TTL threshold 3-11

PM 3580/PM 3585 User Manual

turning on 1-10, 11-9
twy 5-7
two window display 6-34
type of bus transfers 7-6
type of data stored 3-16, 5-4
type of sequence 3-15
types of adapter 8-7
types of fields 3-4

U

U.S.A. addresses 11-24
units 6-13
units cursor positioning 6-13
unrel. mnemonic 7-6
unsigned operands 7-5
unused opcode mnemonic 7-6
user hardware specifications 9-1-9-7
User manual 1-7, 11-2
user safety 11-3
user-defined sequences 3-15, 3-16, 5-7
user-defined trigger position 5-6
utilities 12-1-12-4
utilities disk 12-2
utilities menu 12-2, 12-4

V

valid for clock 4-9
 default 4-11
 range detector 5-12
validity of label for clock 4-9
value entry 5-20
value of time-out 5-25
values field 6-23
values of operands 7-5
vertical scale 6-22
video connector 2-8, 9-6
viewing data 6-12
visible data 6-2, 6-14
voltage adjustment and fuse unit 2-8
voltage selector 2-8, 11-7
voltage setting 11-7

W

wait for a pattern sequence example 5-31
warning 11-3, 11-4, 11-5, 11-6, 11-7
warning symbols 11-4
waveform display 3-18, 6-18-6-27
waveform display height 6-22
window deletion 6-35
window, active 6-35
windows, moving between 6-35
wire wrap pin connection 8-5
word pairs 5-11

X

X cursor 3-19, 6-12, 6-18, 6-19
X position field 6-12

Y

Y cursor 3-19, 7-9, 6-12, 6-29
Y-scale 6-22



LOGIC ANALYZERS

PM 3580 / PM 3585

**JTAG / IEEE 1149.1
Boundary-Scan Protocol
Analysis Package**

PF 8683

Insert this document as an appendix of your
PM 3580/PM 3585 User Manual.

Publication Number 4022 104 90771

Logic Analyzers PM 3580/PM 3585

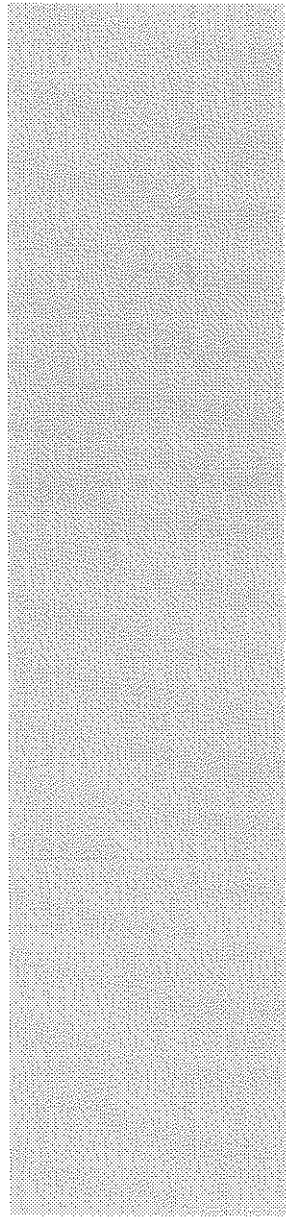

■ PF 8683/3x Boundary-scan disassembler
Software Version 1.01
IE, Test & Measurement
© Copyright 1991, Philips Export B.V.



Printed in the Netherlands

Table of Contents

Introduction	5
Adapter	5
Adapter Modes	6
Switch TDI/TDO	7
Disassembler	8
Installation	9
Application Notes	10
Signal Labels	10
Timing Analysis	10
State Analysis	10
Channel to Signal Assignment	11
Adapter Connector 1	11
Adapter Connector 2	12
TAP Connector Pinning	12
Technical Data PF 8683/x6	13
Electrical Data Adapter	13
Mechanical Data Adapter	13
Environmental Data	14

Logic Analyzers PM 3580/PM 3585

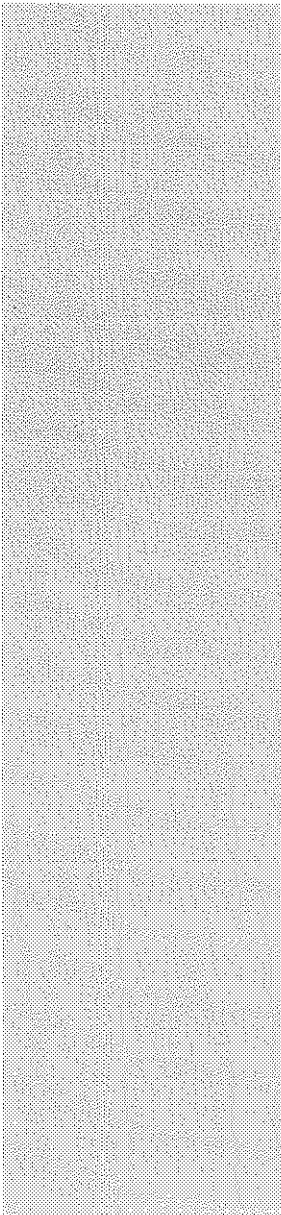

Introduction

Compatibility

The JTAG / IEEE 1149.1 Boundary-Scan Protocol Analysis Package consists of a:

- Boundary-Scan TAP Adapter.
- Boundary-Scan Disassembler.

The package is used in combination with the Philips PM 3580/PM 3585 Logic Analyzers. It allows simultaneous timing and state analysis of the signals of a Test Access Port (TAP).

The design of the adapter complies with the JTAG / IEEE 1149.1 Standard Test Access Port and Boundary-Scan Architecture. It supports the 5 signals defined in the standard TCK (Test Clock), TDI (Test Data Input), TDO (Test Data Output), TMS (Test Mode Select) and TRST* (Test Reset).

The disassembler displays the TAP controller states as defined in the standard (Test-Logic-Reset, Run-Test/Idle, Select-DR-Scan, etc.).

Adapter

Dual Analysis

The adapter has been designed such that the Dual Analysis Per Pin architecture of the Logic Analyzer can be fully exploited. Simultaneous measurements in the timing and state domain without any reconnection or multiple probing of TAP signal lines are possible.

This single probing methodology also avoids additional DC and AC loading of the TAP signal lines.

Supply Voltage

The adapter contains active circuitry which is powered by the Logic Analyzer.

Adapter Connections

The adapter can be connected to the interface cable between a boundary-scan tester and the Test Access Port (TAP) of a board under test. The adapter contains two 10-pin TAP connectors for this purpose.

These input connectors are connected in parallel and can thus be used as a feed through for the Boundary Scan signals (see figure below).

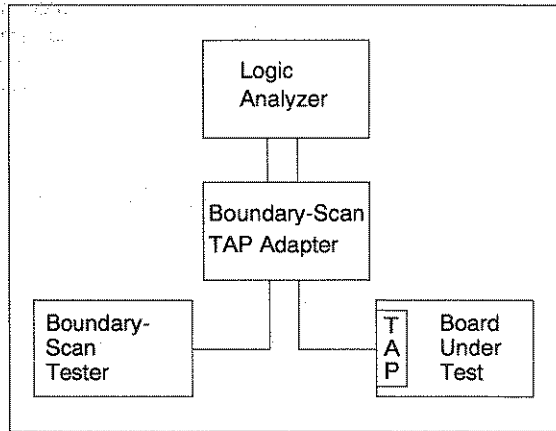

The adapter contains two 40-pin connectors to connect the adapter to the logic analyzer. Depending on the mode in which the adapter is used only one or both connectors are required.

Adapter Modes

Mode I

The Boundary-scan adapter can be used in one of two different modes as controlled by the switch labeled "MODE" on the adapter.

When the Mode switch is set to "I" the adapter collects 16 shift (scan) operations and presents these as 16-bits data in parallel to the analyzer. These 16 bits of data are displayed on a single line in the state display.

The scanned data is to be read from left to right, i.e. the left most bit is the first of these 16 bits.

Note that the adapter automatically handles boundary-scan chains, the length of which is not a multiple of 16 bits. Also consecutive Run-Test/Idle and Pause states are dis-

Boundary scan support

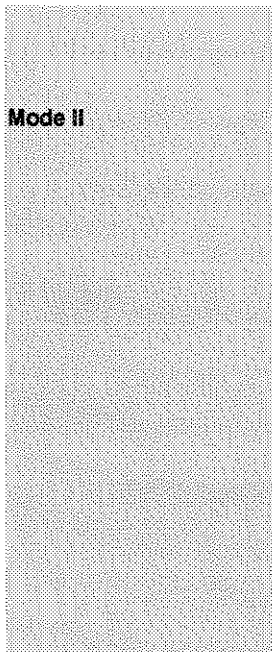

played on a single line together with the number of times the state occurred. In this mode both 40-pin connectors have to be used.

When the Mode switch is set into position "II" the 16-bit data collection mechanism of the adapter is disabled. Each data bit shifted is now displayed on a separate line in the state display. Furthermore consecutive Run-Test/Idle and Pause states are displayed on multiple lines. In this mode only one 40-pin connector has to be used.

Mode I clearly allows for a longer time interval (more scan patterns) to be traced than Mode II at the expense of 16 additional channels.

Note: The Logic Analyzer cables can be directly connected to the adapter. The adapter connectors contain RC networks for correct signal adaption from the adapter to the Logic Analyzer.

CAUTION

Using the pod cable without the right RC networks can damage the Logic Analyzer.

Switch TDI/TDO

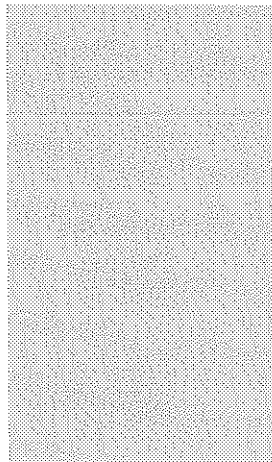

By means of the switch labelled "SHIFT" you can select to display either the input of the scan chain "TDI" or the output "TDO" in the disassembler output column.

Disassembler

A distribution disk is provided together with the adapter. This disk contains the disassembler file (B_SCAN.DIS).

The disassembler is compatible with System Software version 1.01 onwards.

The disassembler automatically configures the Logic Analyzer. Pods are assigned as necessary, all label and clock assignments (including attributes) are made in the Format menu, and the Display menu is updated.

After the disassembler has been loaded, the Logic Analyzer display screen shows the captured data with the proper signal names.

The disassembler analyzes the data that has been captured and displays the states of the TAP controller on the board under test together with the data that has been shifted into and out of the boundary-scan chain.

The labels in the Format menu correspond with the Test Access Port signal names defined in the IEEE 1149.1 standard. The TRST* signal, however, is labeled TRSTN.

The TAP controller states are identified by the names defined in the IEEE 1149.1 standard.

Extra signals are generated by the adapter, these signals are only relevant in the state domain and are needed for disassembly.

Naming Convention

Installation

To install your Boundary-scan adapter and disassembler, complete the following procedure:

1. Disconnect the target system from any power source.
2. Switch off the Logic Analyzer.
3. Connect the pod cables 1 and 2 to the adapter connectors 1 and 2 in sequence. For mode II, only pod 1 is sufficient.
4. Ensure that the TAP connector pins on the adapter are connected with the corresponding Boundary-scan signals on the target.

CAUTION

Incorrect connection of the adapter can damage the adapter and the Boundary-scan target.

5. Switch on the Analyzer.
6. Power up your target. Proper working of the adapter requires that the reset sequence of the Boundary-scan target must be completed with the adapter connected.
7. Load the appropriate disassembler file (B_SCAN.DIS) from the distribution disk using the option field in the Configuration menu.

CAUTION

Do not connect the adapter onto the Logic Analyzer or target system with power applied to your Logic Analyzer or target system. Integrated circuits contain protective circuitry against damage due to ESD. However, it is advised that normal precautions be taken to avoid application of any voltages higher than the maximum rated voltages to the adapter.

Application Notes

Signal Labels

All the adapter signals are labeled in the Format menu. Additionally bus labels provide some signal combinations.

The bus labels are:

- "STATE", containing the encoded states of the TAP-controller.
- "SQIO", containing information on the mode of operation and which data is displayed in the disassembler output column, TDI or TDO.
- "DATA", containing either the data for the Scan registers, or indicating the number of times the Run-Test/Idle state or Pause state occurred uninterrupted.

Timing Analysis

Only the IEEE 1149.1 signals (TCK, TMS, TDI, TDO and TRST*) are used for timing analysis.

State Analysis

The TAP-controller signals TCK, TMS and TRST* are used to generate the 16 encoded instructions according to the IEEE 1149.1 standard.

The Logic Analyzer uses the STCK signal as analyzer state clock. The positive-going signal edge is used to sample the data.

The Clock/Qualifier expression used is:

STCK ↑•QUAL⁻

Notes:

"↑" = Positive-going clock signal edge.

"-" = Logic high level of clock-qualifier QUAL.

Channel to Signal Assignment

The first digit of the adapter channel number corresponds with the pod number.

The last two digits of the adapter channel number correspond with the pod channel number.

For example: Adapter channel 1.06 corresponds with pod 1 and channel 6

Adapter Connector 1

Adapter Channel Number	Analyzer Screen		Boundary Scan Signal Name
	Label	Index	
1.00	INSTR	0	3)
1.01	INSTR	1	3)
1.02	INSTR	2	3)
1.03	INSTR	3	3)
1.04	SQIO	0	3)
1.05	SQIO	1	3)
1.06	QUAL ^{1,3}		3)
1.07	STCK ^{2,3}		3)
1.08	TRSTN ⁴		TRST*
1.09	TCK		TCK
1.10	TMS		TMS
1.11	TDI		TDI
1.12	TDO		TDO
1.13	-		
1.14	TDIS		3)
1.15	TDOS		3)

Notes page 8683-12

Logic Analyzers PM 3580/PM 3585

Adapter Connector 2

Adapter Channel Number	Analyzer Screen Label	Index	Boundary Scan Signal Name
2.00	DATA	0	3)
2.01	DATA	1	3)
2.02	DATA	2	3)
2.03	DATA	3	3)
2.04	DATA	4	3)
2.05	DATA	5	3)
2.06	DATA	6	3)
2.07	DATA	7	3)
2.08	DATA	8	3)
2.09	DATA	9	3)
2.10	DATA	10	3)
2.11	DATA	11	3)
2.12	DATA	12	3)
2.13	DATA	13	3)
2.14	DATA	14	3)
2.15	DATA	15	3)

Notes:

1. Used as Logic State Analyzer clock-qualifier.
2. Used as Logic State Analyzer clock.
3. Artificial signal generated on adapter.
4. Active low signal.

TAP Connector Pinning

The pin assignment of the TAP connector is listed below.

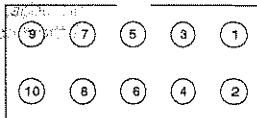

Pin	Signal	Pin	Signal
1	TRST*	6	GND
2	GND	7	TMS
3	TDO	8	GND
4	GND	9	TCK
5	TDI	10	GND

Technical Data PF 8683/x6

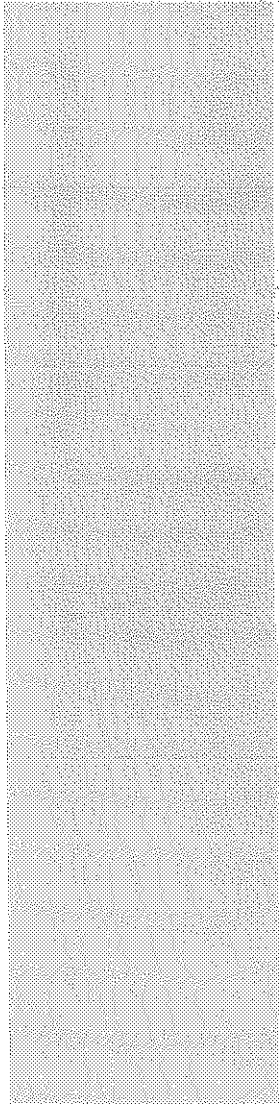

Electrical Data Adapter

Characteristic	PF8683/36	Unit
Input capacitance ¹ (typ.)	40	pF
Input leakage current	± 10	µA
Input voltage VIL min.	-0.3	V
VIL max.	0.8	V
VIH min.	2.0	V
VIH max.	V _{DD} +0.3	V
Max. TCK clock frequency	12.5	MHz
Min. setup time ²	40	ns
Min. hold time ²	10	ns
Max. voltage	6	V
ESD immunity	2	kV

Mechanical Data Adapter

Characteristic	PF8683/x6	Unit
Contact life	100	cycles
Dimensions (l,w,h) ³	62, 112, 36	mm

- Notes:
1. Adapter connected to Logic Analyzer.
 2. Setup time and hold time with respect to the positive-going TCK signal edge, which is used as Logic State Analyzer clock.
 3. Without pod cables.

Logic Analyzers PM 3580/PM 3585

Environmental Data

Characteristic	Performance
Standards	MIL-28800D Type III, Class 5, Style E
Temperature:	
- Rated range of use	5 °C to 40 °C (41°F to 104°F)
- Limited range of operation	0 °C to 55 °C (32°F to 131°F)
- Storage and transport range	-40 °C to 70 °C (-40°F to 158°F)
Relative humidity:	
- Operating	15% to 90% non condensing
- Storage and transport	5% to 95% non condensing
Altitude:	
- Operating	4500 m (15000 ft.)
- Storage and transport	12000 m (40000 ft.)

Please refer to your Service Manual for the Logic Analyzer characteristics not mentioned.

Philips reserves the right to modify specifications without notice.